

TWINZ

TWINZ COLLECTION

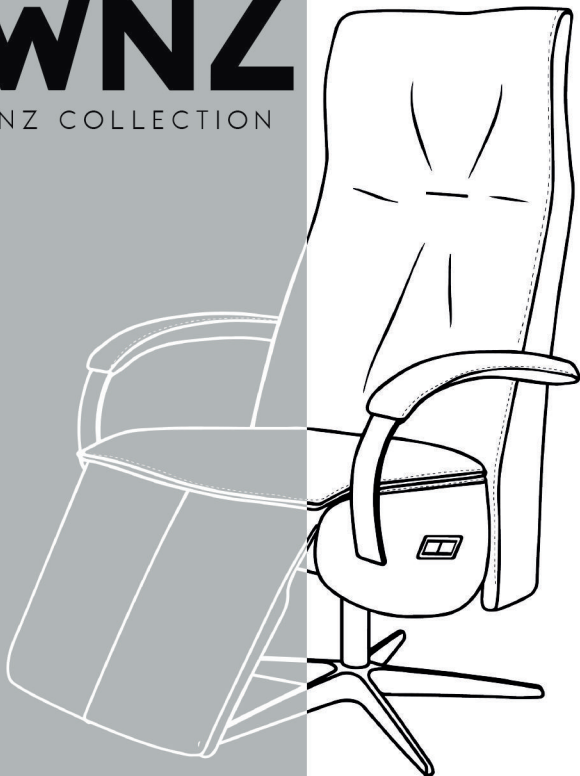

INSTRUCTIONS MANUAL



TABLE OF CONTENT



CHARGING
AUFLADE
OPLADEN



FEATURES
FUNKTIONEN
FUNCTIES



CHAIR DYNAMICS
SESSEL FUNKTIONEN
STOEL FUNCTIES



HEART BALANCE
HERZ-WAAGE
HART BALANS



LEATHER INFORMATION
LEDERINFORMATIONEN
LEDEREN INFORMATIE



INSTRUCTIONS MANUAL ————— 2



BEDIENUNGSANLEITUNG ————— 7



GEBRUIKSAANWIJZING ————— 12



In order to charge the chair, plug the accumulator in the back of the chair and then connect it to the power source

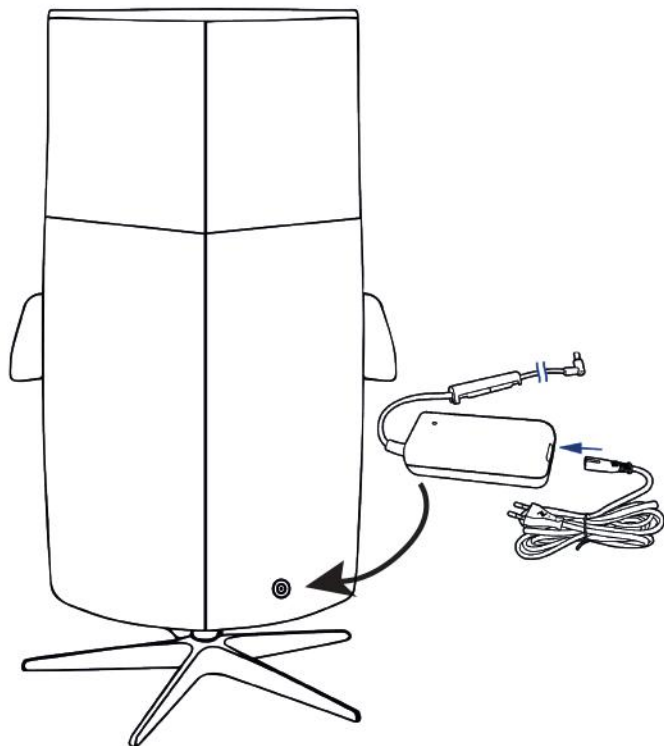

FEATURES

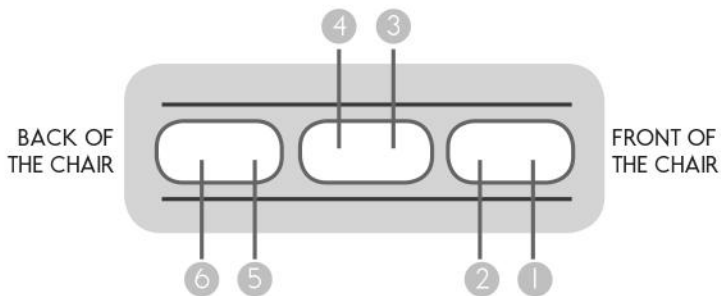

- 1: FOOTREST OUT
- 2: FOOTREST DRAW BACK
- 3: RETRACT HEART BALANCE/RESET
- 4: ACTIVATE HEART BALANCE
- 5: BACKREST UP
- 6: LOWER BACKREST

*The diagrams are informative as the design of the chair may differ



BACKREST

To lower the backrest, press "6" and to bring it back up, press "5".

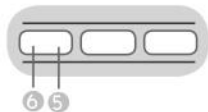

FOOTREST

Press "1" to bring the footrest out and "2" to slide it back in.

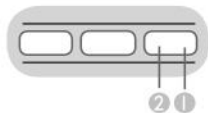

HEART BALANCE

ACTIVATE AND RETRACT HEART BALANCE

Press "4" to activate Heart balance and "3" to come back up or to reset all functions to upright position.

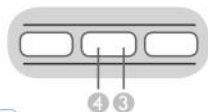

HEART BALANCE

This system aligns the position of the heart in line with the legs resulting in minimal effort for the heart and is experienced as extremely restful.

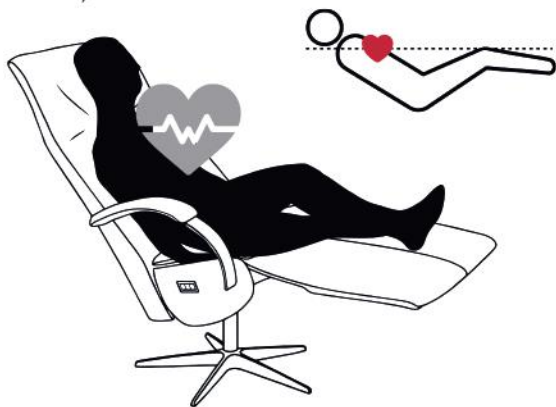

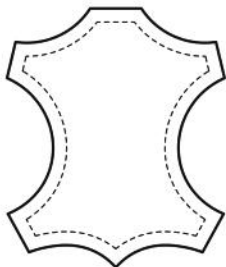

For upholstered furniture with leather covers, it is normal for ripples to appear over time. Leather is a natural product which, under the influence of body heat in connection with body pressure and body moisture, expands to a greater or lesser extent and thus forms waves.

It is a natural process that can be seen as a characteristic of casually processed models. The thinner the cover material and the larger the upholstered surface, the greater the tendency to wrinkles and hollows.

This visual change has no influence on use, function and service life and does not represent a material defect.

AUFLADE

Um den Sessel aufzuladen, muss das Ladegerät zunächst in die Ladebuchse auf der Rückseite des Sessels gesteckt werden und im Anschluss in die Steckdose.

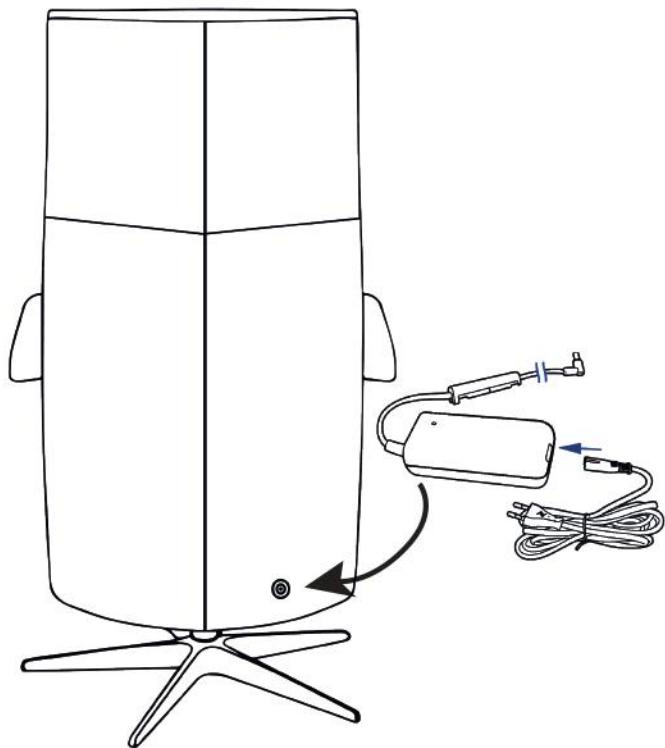

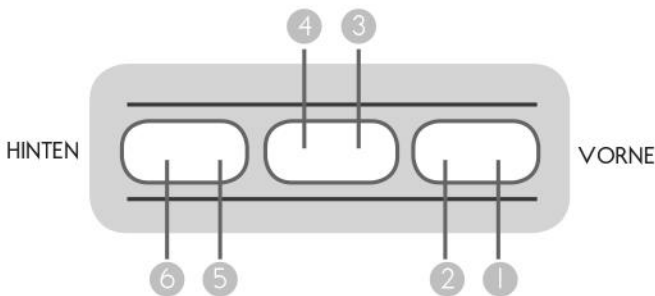

- 1: FUSSTÜTZE FÄHRT AUS
- 2: FUSSTEIL FÄHRT IN AUSGANGSPOSITION ZURÜCK
- 3: ZURÜCKSTELLUNG HERZWAAGE-FUNKTION
- 4: AKTIVIERUNG HERZWAAGE-FUNKTION
- 5: RÜCKENLEHNE BEWEGT SICH NACH VORNE
- 6: RÜCKENLEHNE BEWEGT SICH NACH HINTEN

*Die Abbildung ist rein informativ. Das Design des Sessel kann anders aussehen

SESSEL FUNKTIONEN

RÜCKENLEHNE

Um die Rückenlehne nach hinten zu verstellen muss der Knopf „6“ betätigt werden. Um die Rückenlehne wieder nach vorne zu verstellen muss der Knopf „5“ eingedrückt werden.

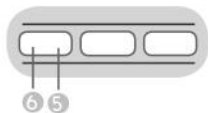

FUSSTEIL

Durch das Betätigen des Knopfes "1" fährt das Fußteil aus.
Durch Betätigen des Knopfes „2“ fährt das Fußteil wieder ein.

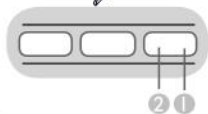

AKTIVIERUNG UND ZURÜCKSTELLUNG HERZWAAGE-FUNKTION

Drücken Sie "4" um die Herzwaage-Funktion zu aktivieren und "3" um die Rückenlehne in die aufrechte Position oder um den Sessel in die Ursprungsposition zu bringen.

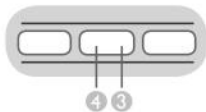

HERZWAAGE

Dieses System ist mit einer sogenannten „Herz-Waage“ Funktion ausgestattet. Die Füße und das Herz liegen in einer gedachten horizontalen Linie, wodurch das Herz minimal belastet wird, was als besonders beruhigend empfunden wird.



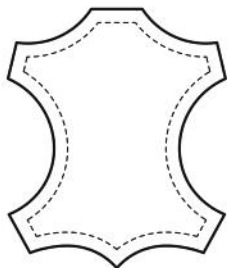

Bei Polstermöbeln mit Lederbezügen ist es normal, dass im Verlaufe der Zeit Wellen entstehen. Leder ist ein Naturprodukt, welches sich unter Einfluss von Körperwärme in Verbindung mit Körperdruck und Körperfeuchtigkeit mehr oder minder ausdehnt und dadurch Wellen bildet.

Es handelt sich um einen natürlichen Vorgang, der als Charaktereigenschaft leger verarbeiteter Modelle zu sehen ist. Je dünner das Bezugsmaterial und größer die verpolsterte Fläche, umso größer ist die Neigung zur Falten und Muldenbildung.

Diese optische Veränderung hat auf Gebrauch, Funktion und Lebensdauer keinen Einfluss und stellt keinen Sachmangel dar.



Om de stoel op te laden, sluit u de accu aan op de achterkant van de stoel en verbindt u hem vervolgens met de stroombron.

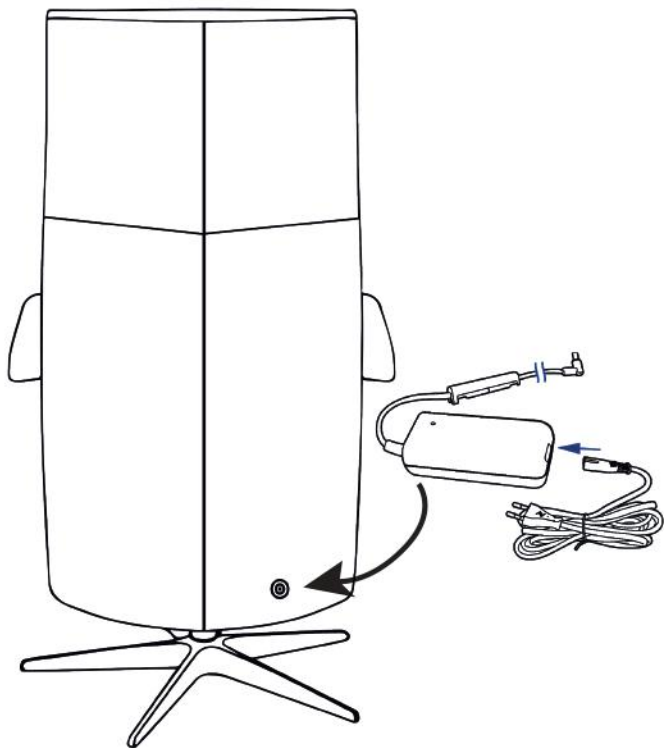

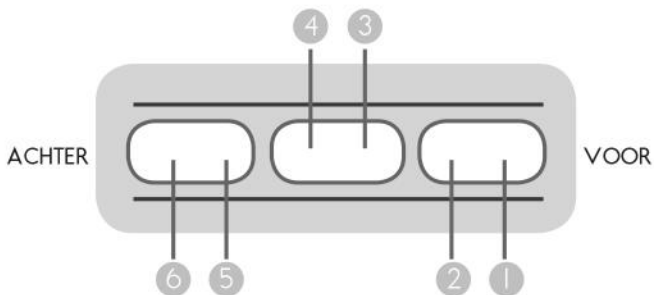

- 1: VOETKLEP UIT
- 2: VOETKLEP NAAR BINNEN
- 3: TERUGSTELLEN HART BALANS FUNCTIE
- 4: ACTIVEREN HART BALANS FUNCTIE
- 5: RUGLEUNING TERUG NAAR RECHTE STAND
- 6: RUGLEUNING NAAR ACHTEREN

*De afbeelding in deze handleiding is informatief, het design van uw stoel kan afwijken van het door uw gekochte model



RUGLEUNING

Om de rugleuning te laten zakken, drukt u op "6" en om deze weer recht te zetten, drukt u op "5".

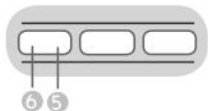

VOETENSTEUN

Druk op "1" om de voetensteun te openen en "2" om hem te sluiten.

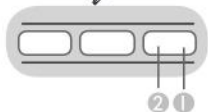

HART BALANS

ACTIVEREN EN TERUGSTELLEN HART BALANS FUNCTIE

Door het gebruik van knop "4" start u de hart balans functie.

Knop "3" functioneert als totale reset functie om de stoel in rechte stand te brengen.

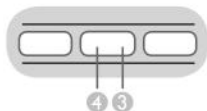

HART BALANS

Dit systeem heeft een hart-balans functie, wat resulteert in minimale inspanning voor het hart en wordt ervaren als uiterst rustgevend.

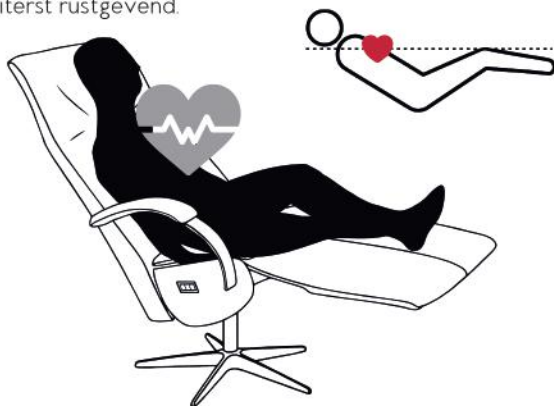

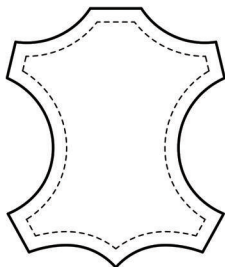

Bij het gebruik van meubels met leren bekleding is het normaal dat er zich plooiën vormen. Leer is een buitengewoon natuurproduct dat rekt en flexible reageert op druk die samenhangt met de beweeglijke bekleding.

De zachtheid en elasticiteit van het oppervlak staan garant voor het comfort van uw zitmeubel. Leer rekt in het bijzonder bij beklede meubels met sterk belaste zittingen of een grote rug.

Bij de vormgeving van moderne fauteuils & bankstellen wordt hiermee rekening gehouden. Leren plooiën en een "nonchelante" stoffering zijn kenmerkend voor een modern design.

Plooivorming vloeit voort uit het gebruik en vermindert de kwaliteit van meubels met een leren bekleding niet. Het is een natuurlijk proces in het lange leven van uw beklede meubels. Leer is een kostbaar en waardevast product.



PLEASE DO NOT SIT ON THE ARMRESTS
IT MAY LEAD TO A PERMANENT TILT OF THE CHAIR

ARMLEGGERS ZIJN GEEN ZITPLAATS
DIT KAN LEIDEN TOT AFBREKEN
OF DE FAUTEUIL PERMANENT SCHEEF
MAKEN EN VALT BUITEN DE GARANTIE

BITTE NICHT AUF DEN ARMLEHNEN SITZEN.
DIES KANN ZU EINER PERMANENTEN
BESCHÄDIGUNG DES SESSELS FÜHREN

