

A254

AUFBAUANLEITUNG - ASSEMBLY INSTRUCTION

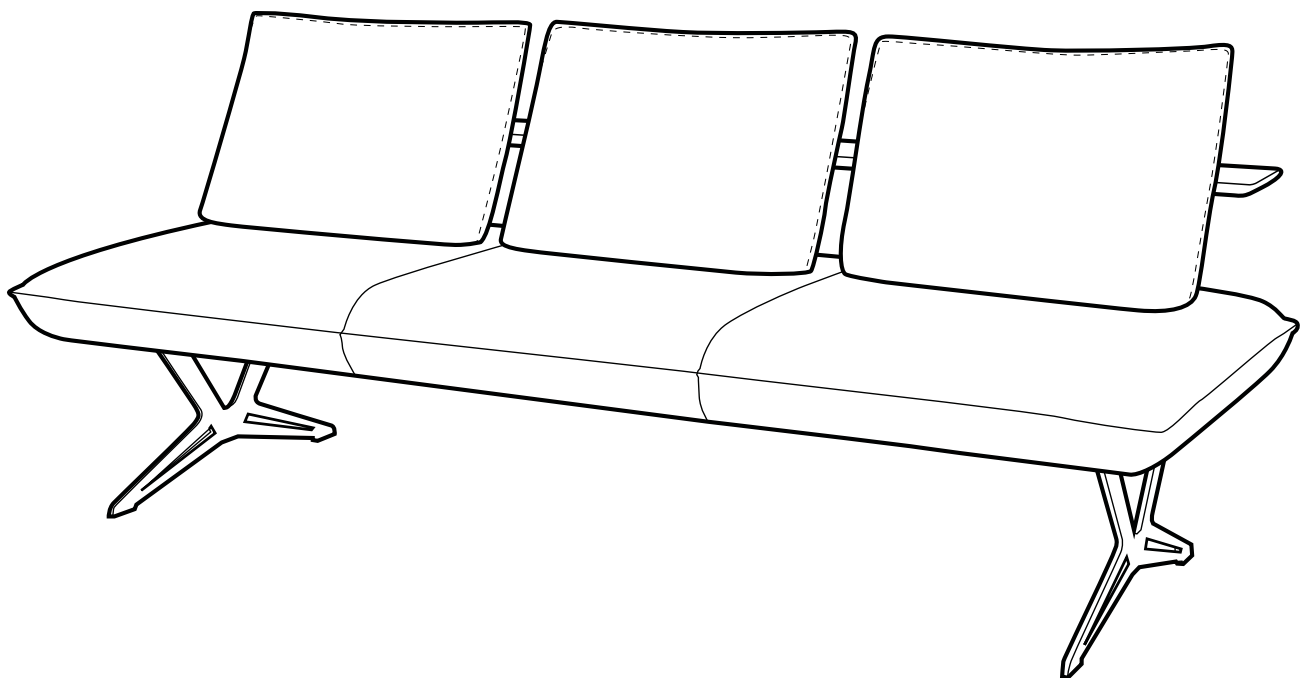



Inbusschlüssel 5 mm
Allen key 5 mm

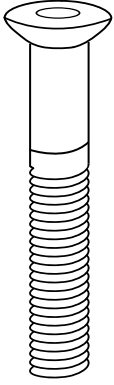

Senkkopfschraube 8x50 mm
Countersunk head screw 8x50 mm

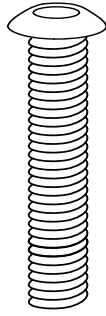

Linienkopfschraube 8x40 mm
Lens head screw 8x40 mm

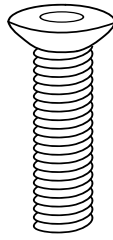

Senkkopfschraube 8x30 mm
Countersunk head screw 8x30 mm

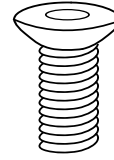

Senkkopfschraube 8x20 mm
Countersunk head screw 8x20 mm



Spaxschraube 5x20 mm
Spax screw 5x20 mm

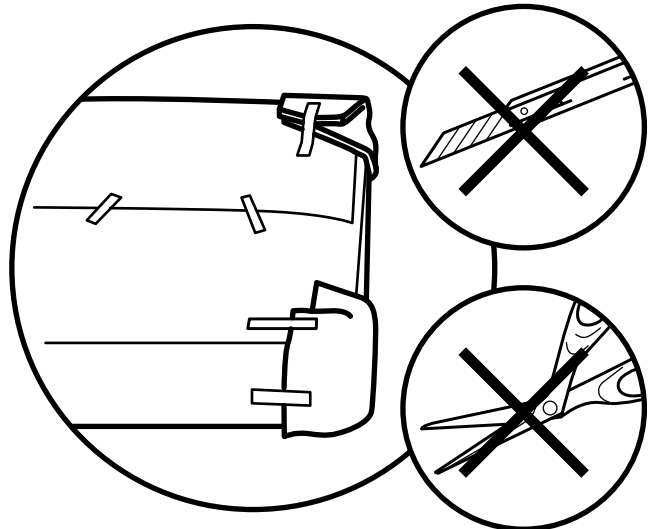
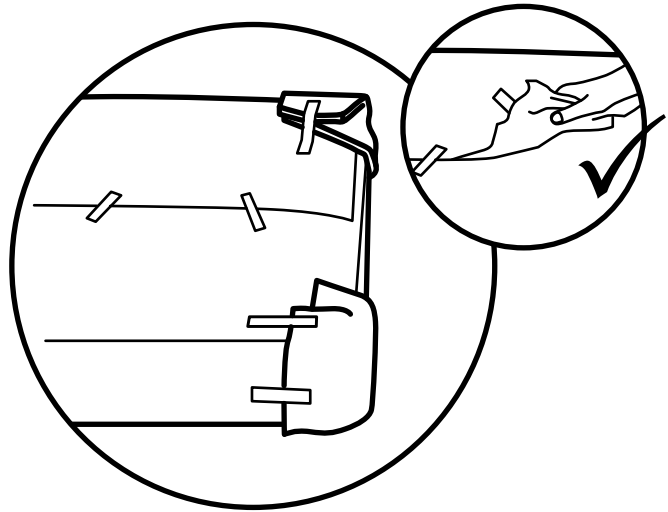
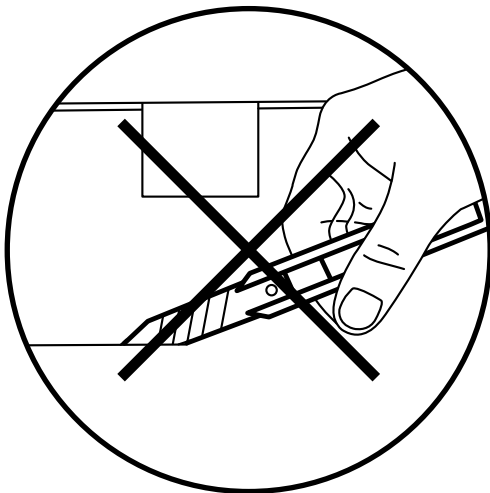
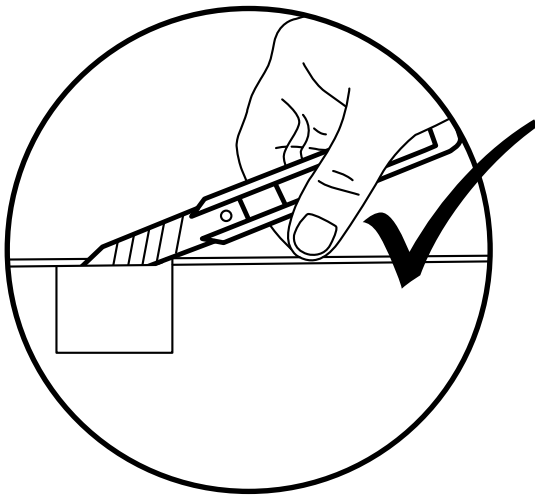

! Hinweis / Note:

Für den Aufbau werden zwei Monteure benötigt. Somit vermeiden Sie Beschädigungen im Vorfeld.

Two persons are needed for the assembly. This prevents damage in advance.

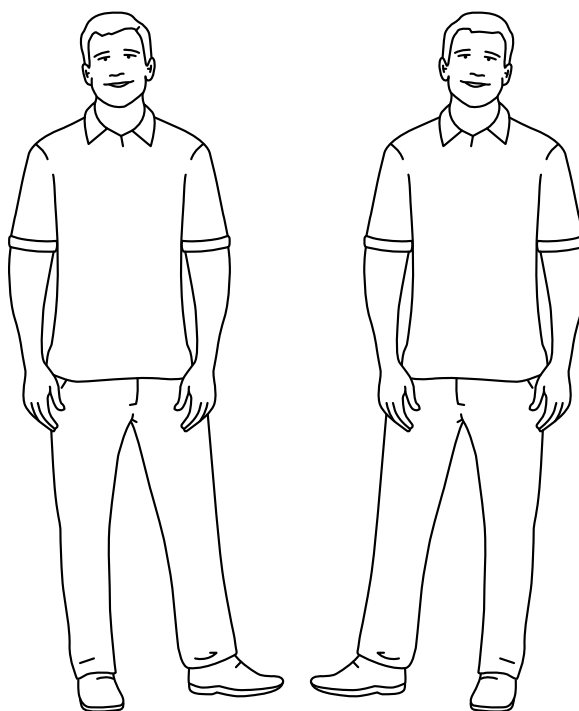

1 Vorbereiten / Preparation

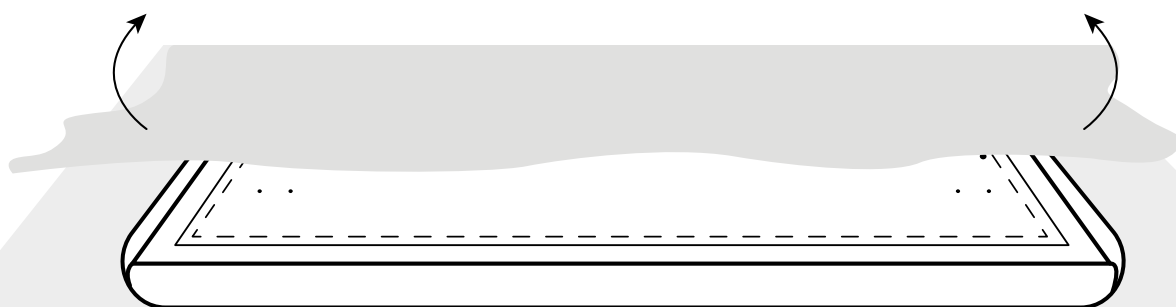

Unterlage / Verpackungsfolie
underlay / packaging foil

2

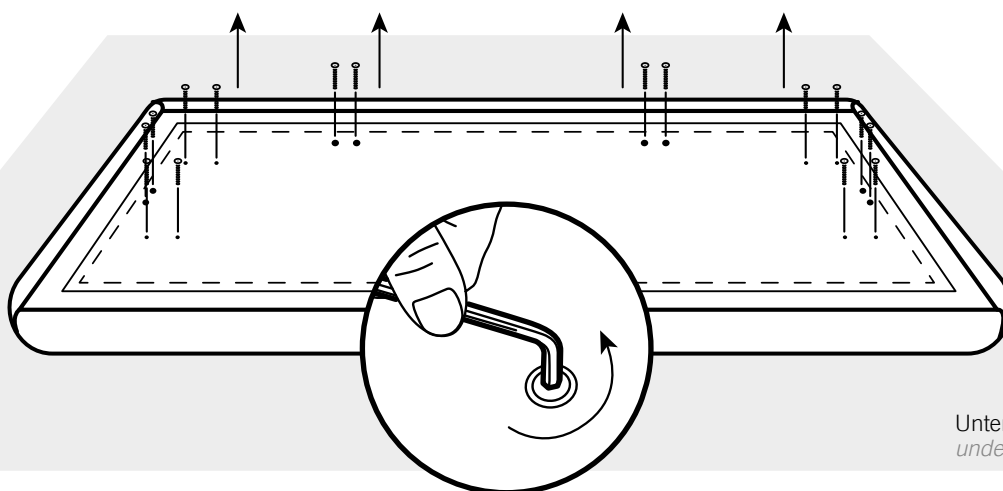

Unterlage / Verpackungsfolie
underlay / packaging foil

3 Montage Kufen und FüÙe / *Runner and feet assembly*

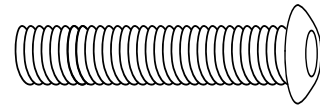

Linsenkopfschraube **8x40 mm**
Lens head screw 8x40 mm

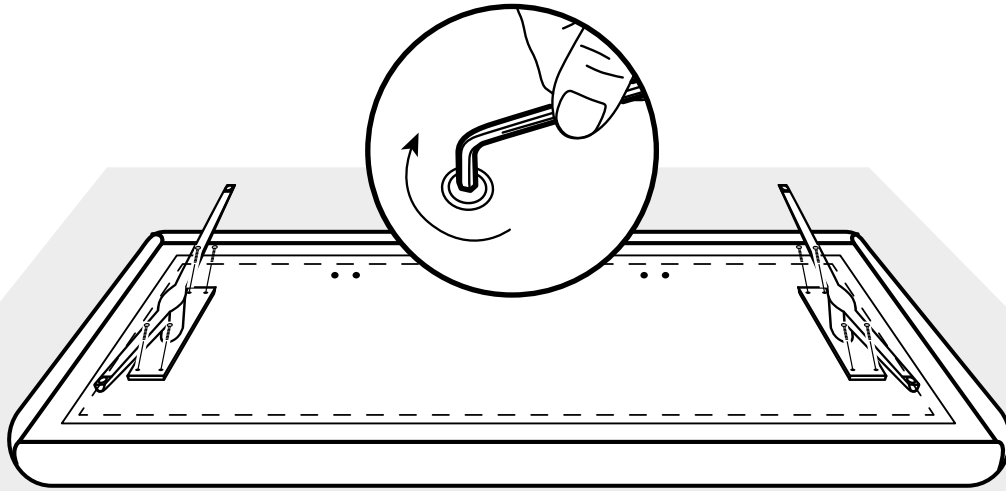

Schwertkufe
Aluminium casting sword runner

4

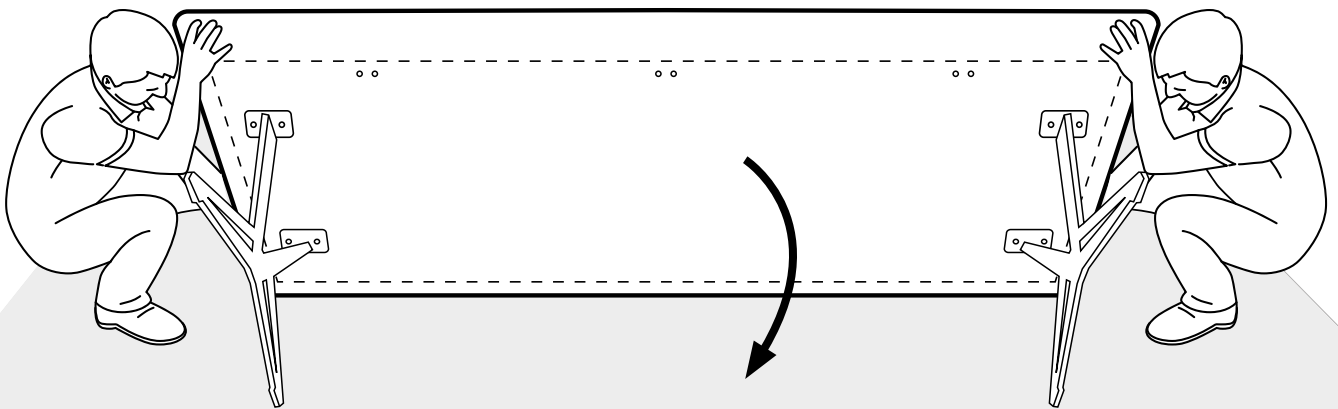

5 Montage Rückenhalter / Back support assembly

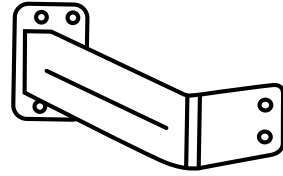

5a Modellabhängig bei Modell **mit** Holzrahmen
*Model-specific for model **with** wooden frame*

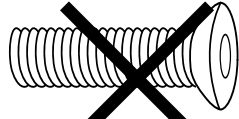

Senkkopfschraube ~~8x30 mm~~
Countersunk head screw ~~8x30 mm~~

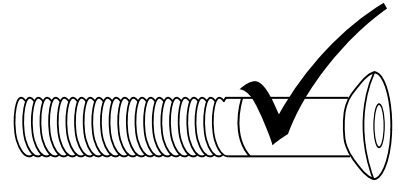

Senkkopfschraube **8x50 mm**
Countersunk head screw **8x50 mm**

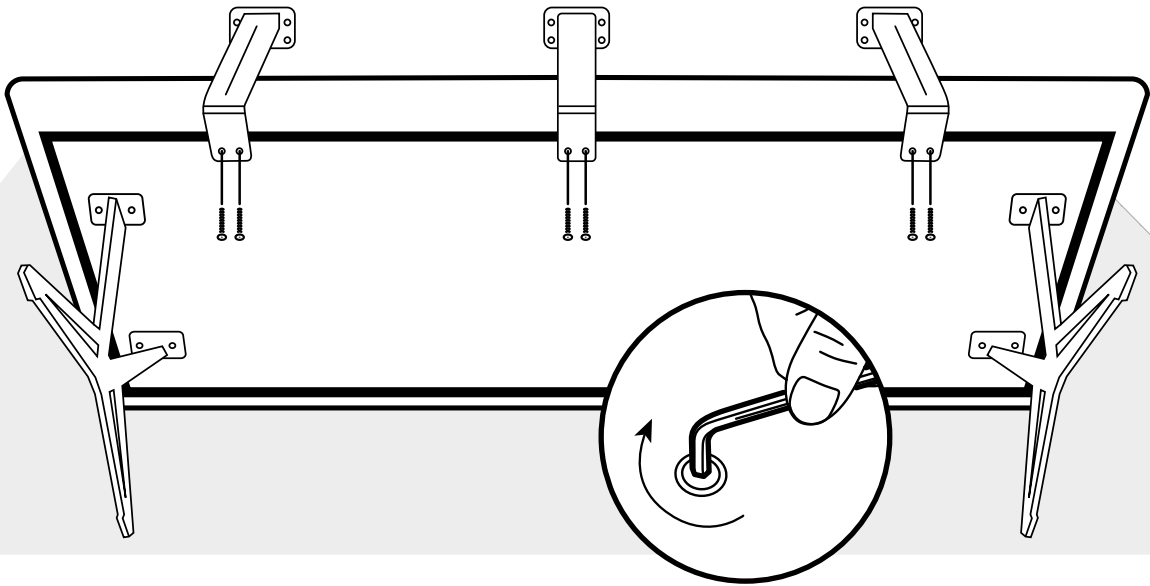

5b Modellabhängig bei Modell **ohne** Holzrahmen
*Model-specific for model **without** wooden frame*

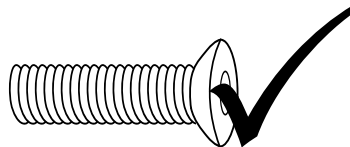

Senkkopfschraube **8x30 mm**
Countersunk head screw **8x30 mm**

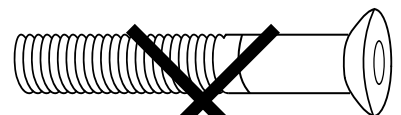

Senkkopfschraube ~~8x50 mm~~
Countersunk head screw ~~8x50 mm~~

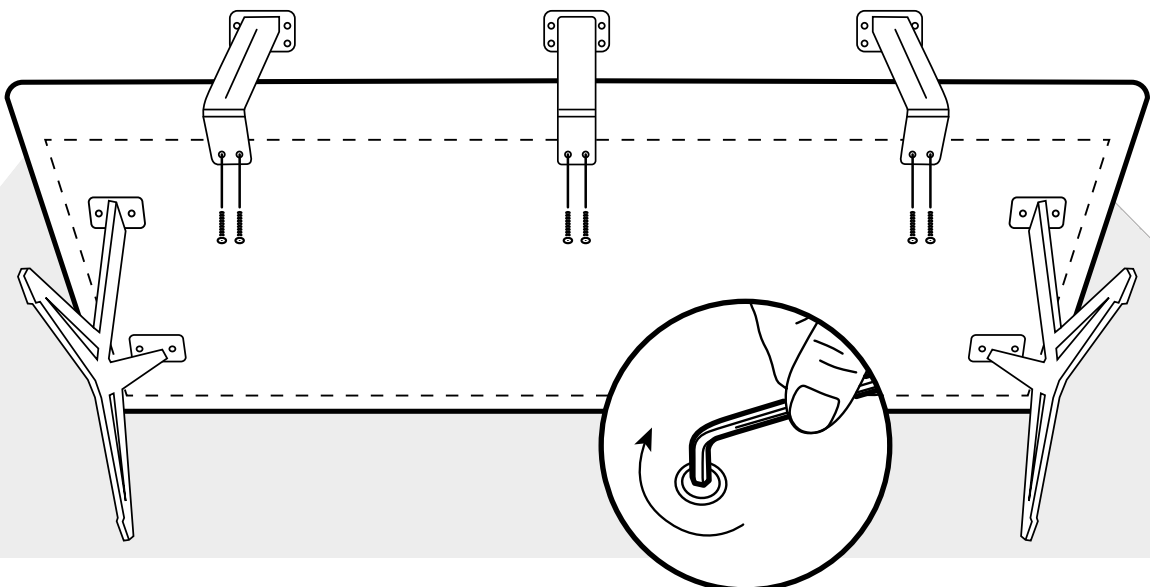

6 Montage Reling / Railing assembly

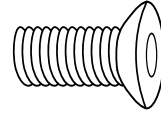

Senkkopfschraube **8x20 mm**
Countersunk head screw **8x20 mm**

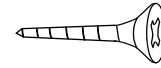
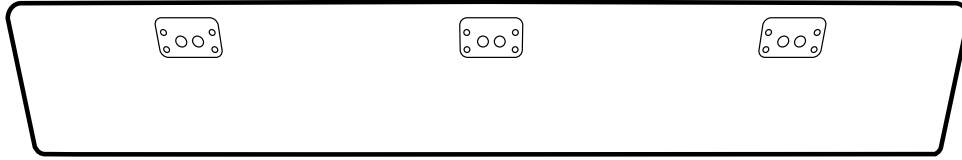

Spaxschraube **5x20 mm**
Spax screw **5x20 mm**

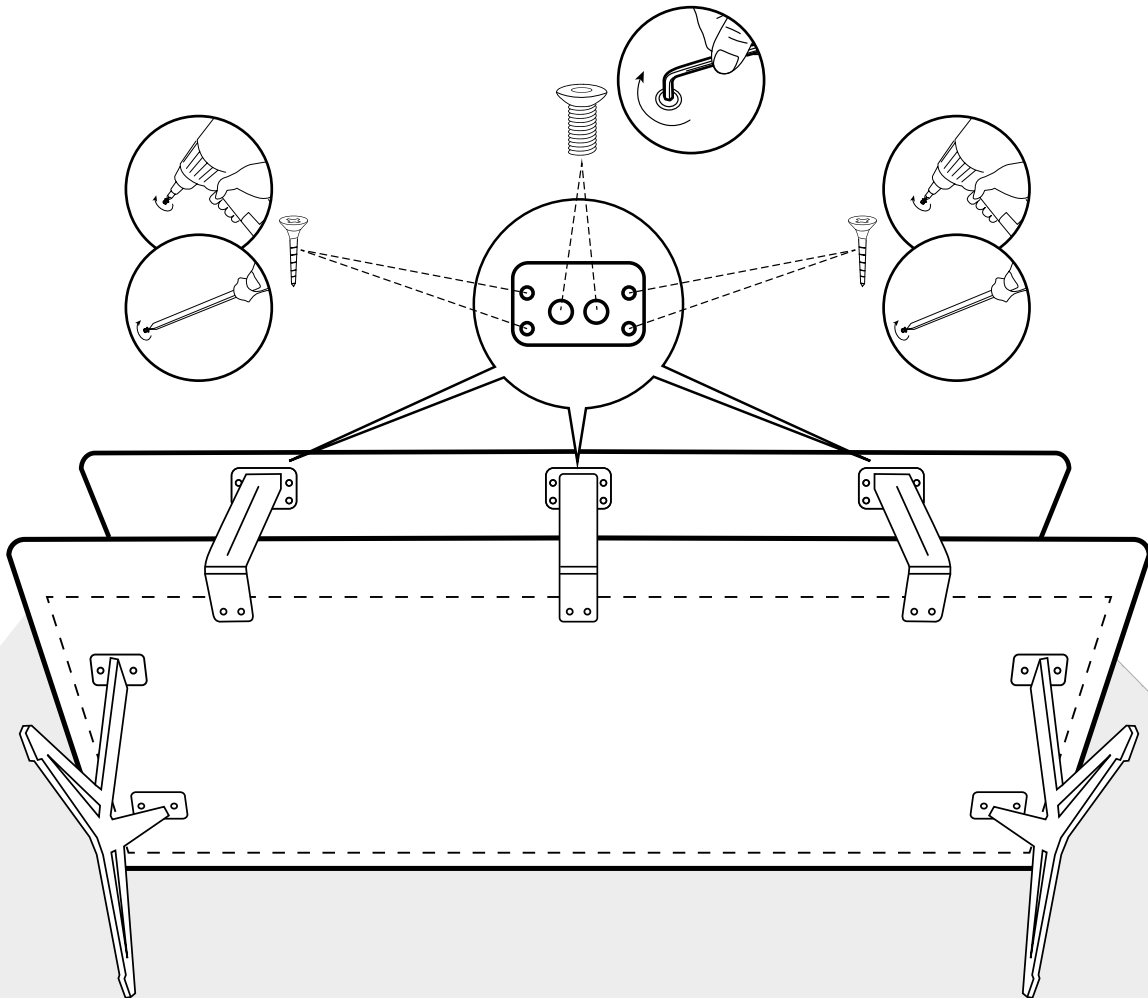

7

