

A259

AUFBAUANLEITUNG - ASSEMBLY INSTRUCTION

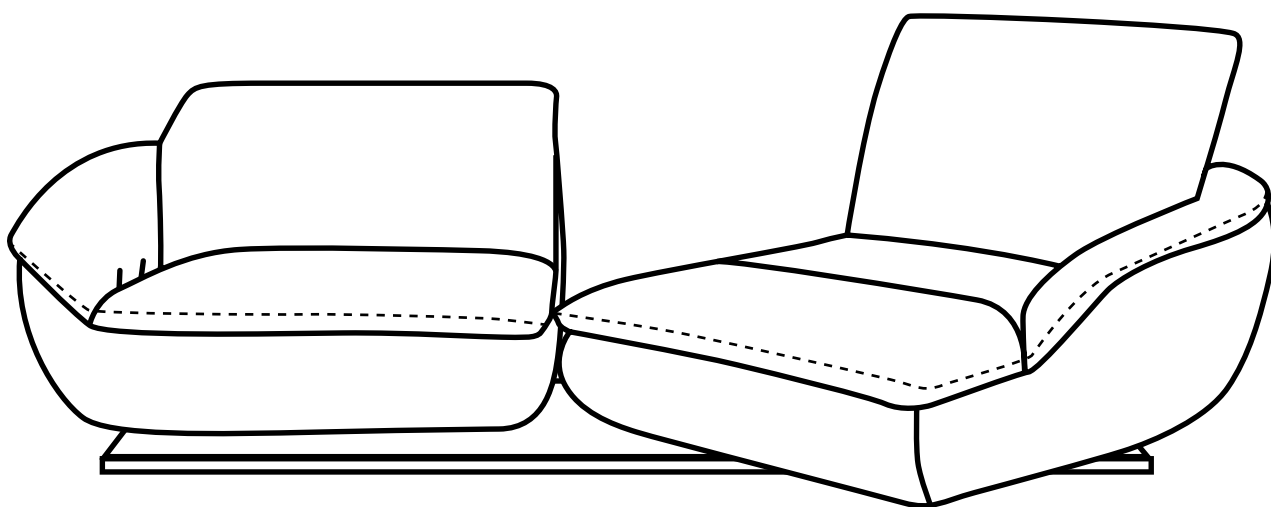

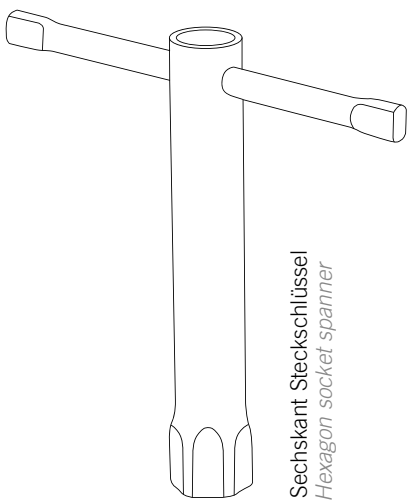

Sechskant Steckschlüssel
Hexagon socket spanner

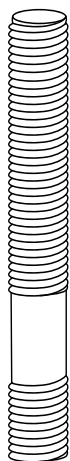

Gewindestift 8x60 mm
Setscrew 8x60 mm

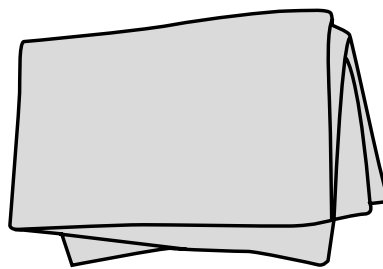

Unterlage / Verpackungsfolie
der Sitzeinheiten
Underlay / packaging foil
of seat elements

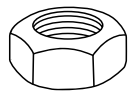

Mutter M 8
Nut M 8

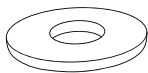

U-Scheibe 8,5 mm
Plain washer 8.5 mm

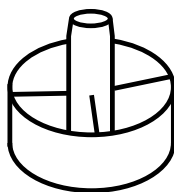

Bodengleiter
Glider

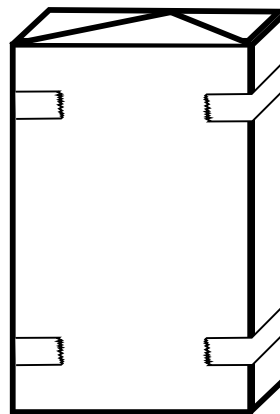

Gefalteter Karton, beige packt bei Sitz:
Montagehilfe Sitze/Plateau
Folded cardboard box, enclosed with the seat:
seat/plateau assembly aid

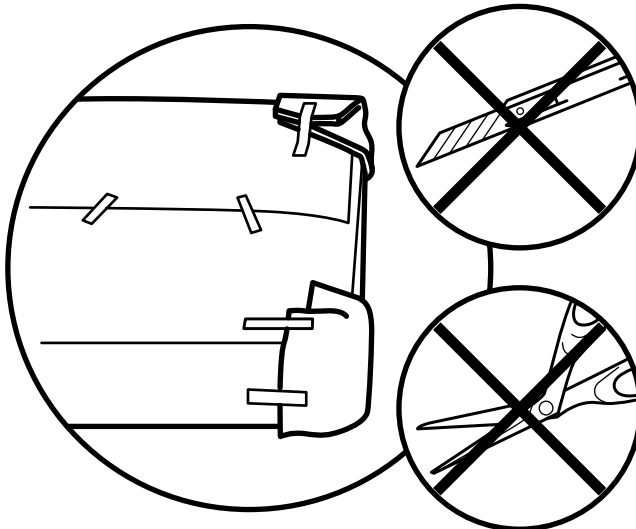
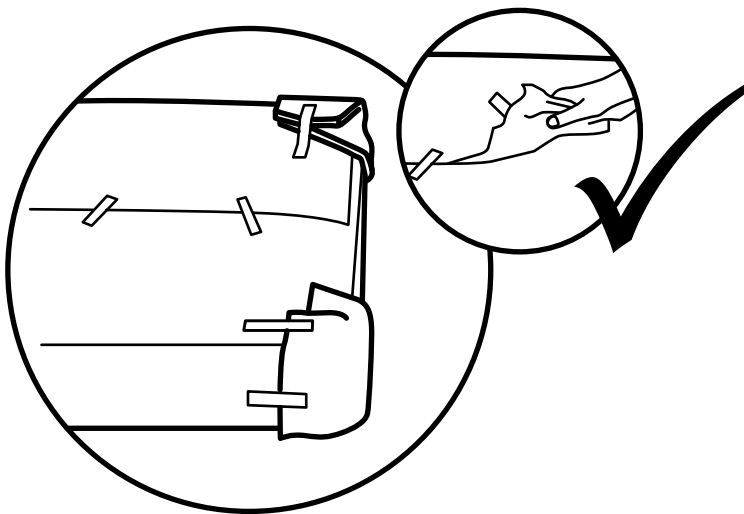
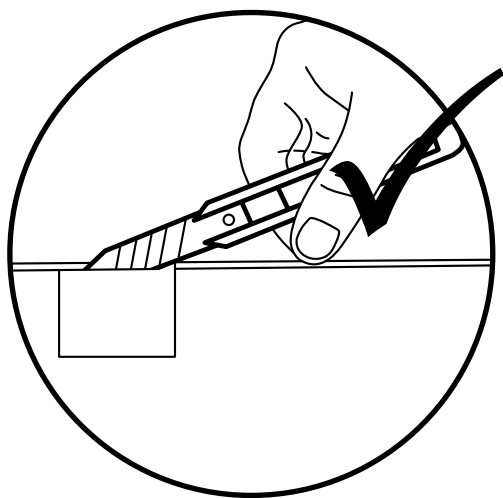

! Hinweis / Note:

Für den Aufbau werden zwei Monteure benötigt. Somit vermeiden Sie Beschädigungen im Vorfeld.

Two persons are needed for the assembly. This prevents damage in advance.

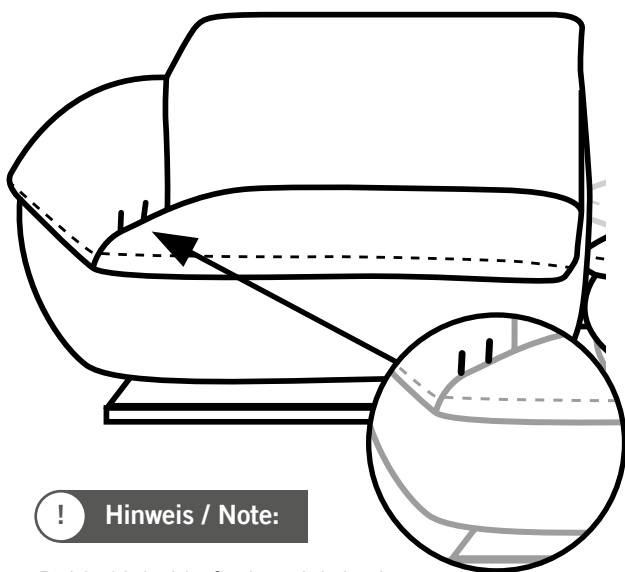
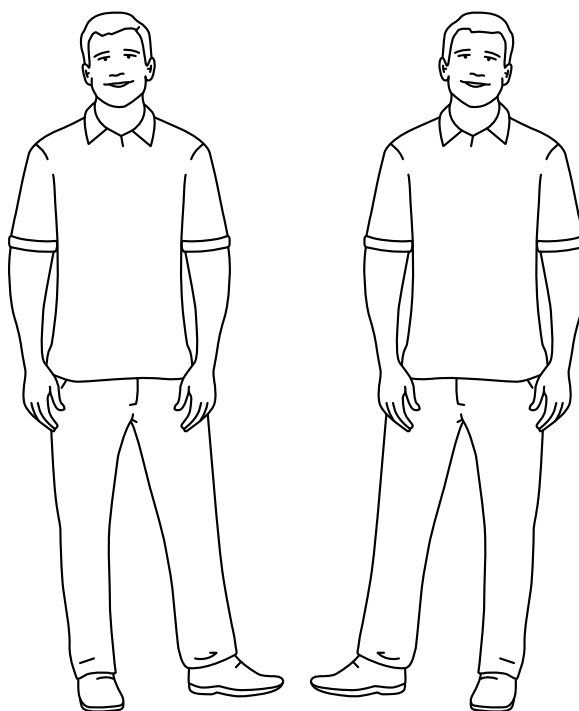

! Hinweis / Note:

Beide Hebel befinden sich in der Transportsicherung! Erst lösen nach kompletter Montage und Aufstellung des Sofas.

Both levers are in the transport lock! Do not release until the sofa has been fully assembled and positioned.

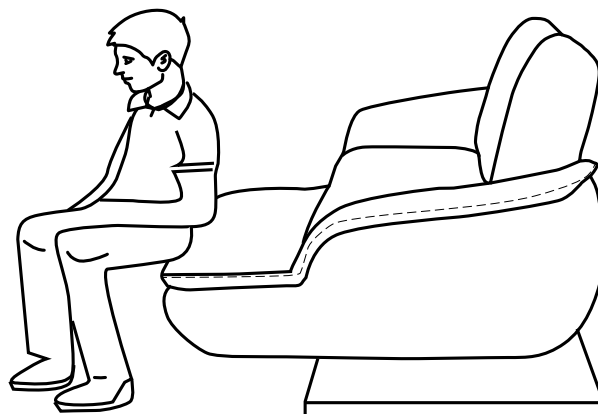

! Hinweis / Note:

Achtung! Kippgefahr!
Bei Ausführung mit Liege bitte nicht auf die äußerste Kante setzen.

*Attention! Danger of tipping!
For models with loungers. Please do not sit on the outermost edge.*

1 Auspacken Sitze / *Seats unpacking*



Unterlage / Verpackungsfolie
nicht wegwerfen!
*Do not throw away the
underlay / packaging foil!*

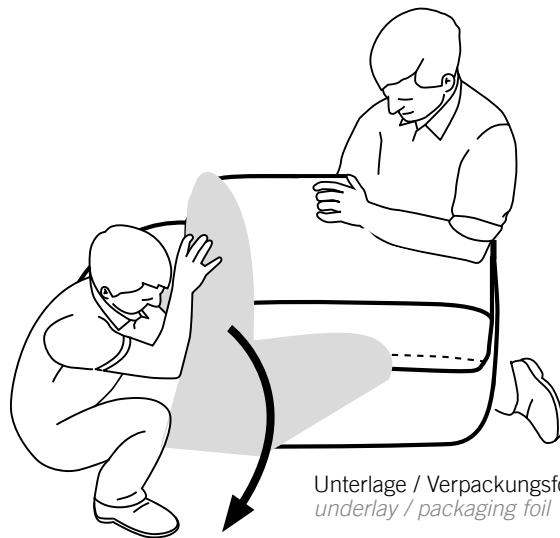

Unterlage / Verpackungsfolie
underlay / packaging foil

2 Auspacken gefaltete Kartons (Montagehilfe) unter dem Sitz
Unpacking folded boxes (assembly aid) under the seat

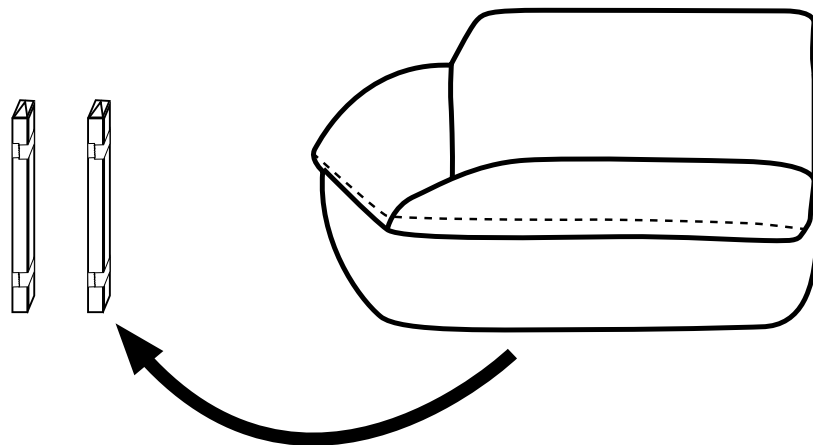

3

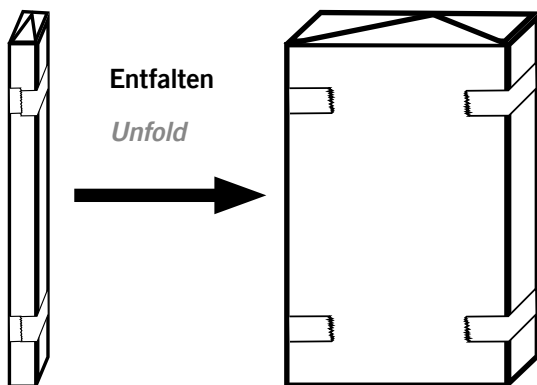

! Hinweis / Note:

Auf Stabilität beim Entfalten achten.
Ensure stability when unfolding.

Kartons (Montagehilfe)
nicht wegwerfen!
*Do not throw away the
boxes (assembly aid)!*



4 Auspacken Plateau / *Plateau unpacking*

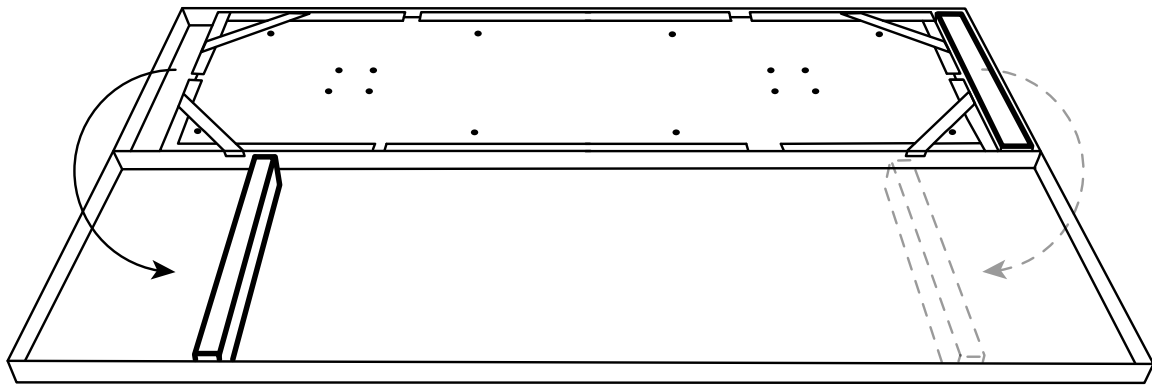

5

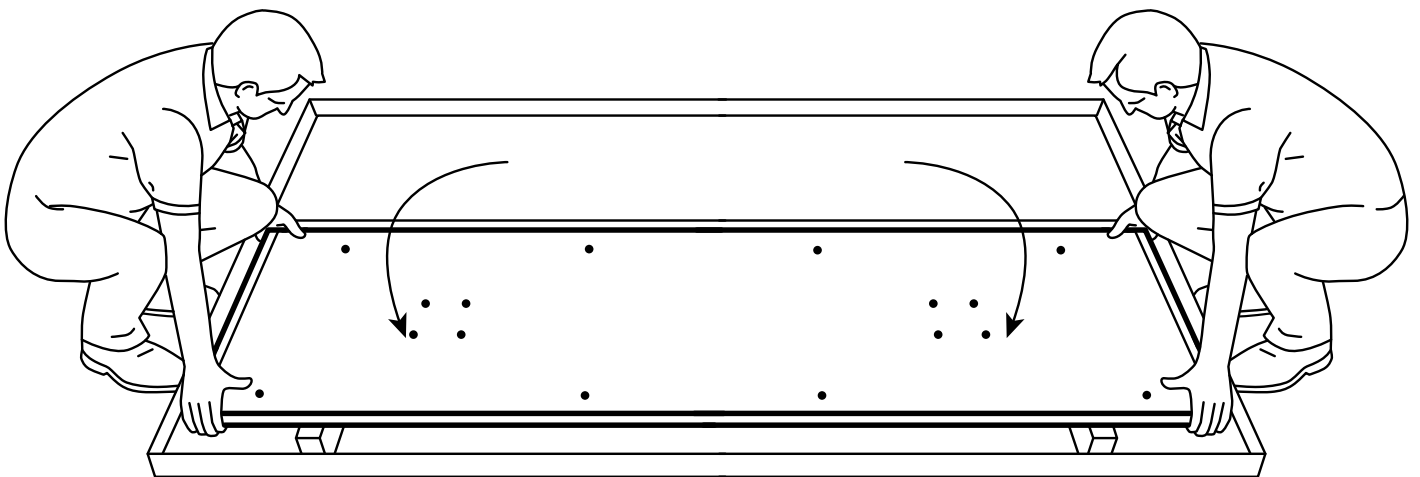

6 Montage Bodengleiter / *Glider assembly*

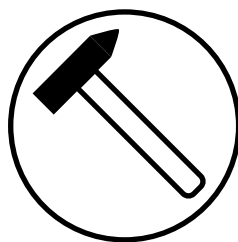
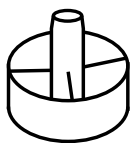

! Hinweis / Note:

Das Plateau ist kratzempfindlich.
Bitte vorsichtig behandeln.
*The plateau is sensitive to scratches.
Please handle with care.*

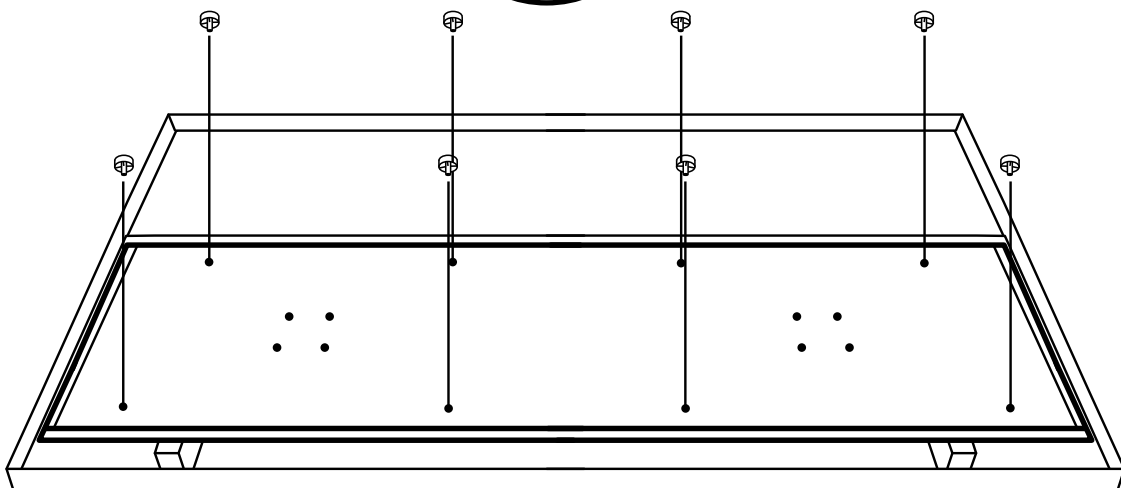

7 Montage Sitze/Plateau / *Seats/plateau assembly*

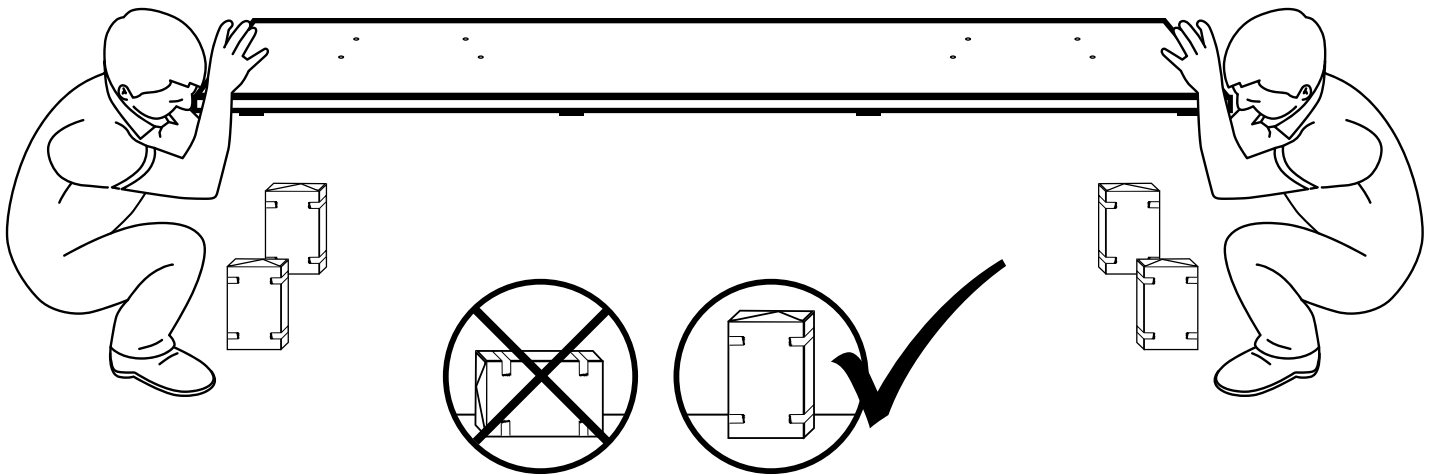

8 Montage Sitze / *Seats assembly*

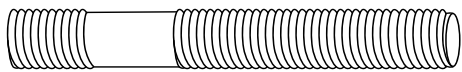

Gewindestift **8x60 mm**
Setscrew **8x60 mm**

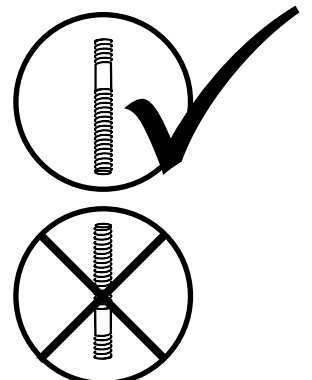
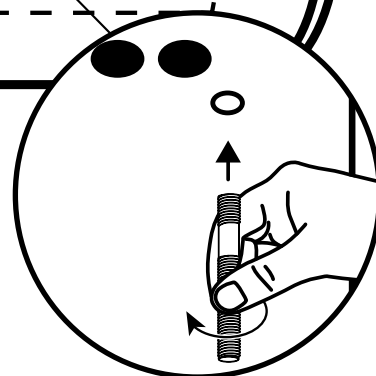
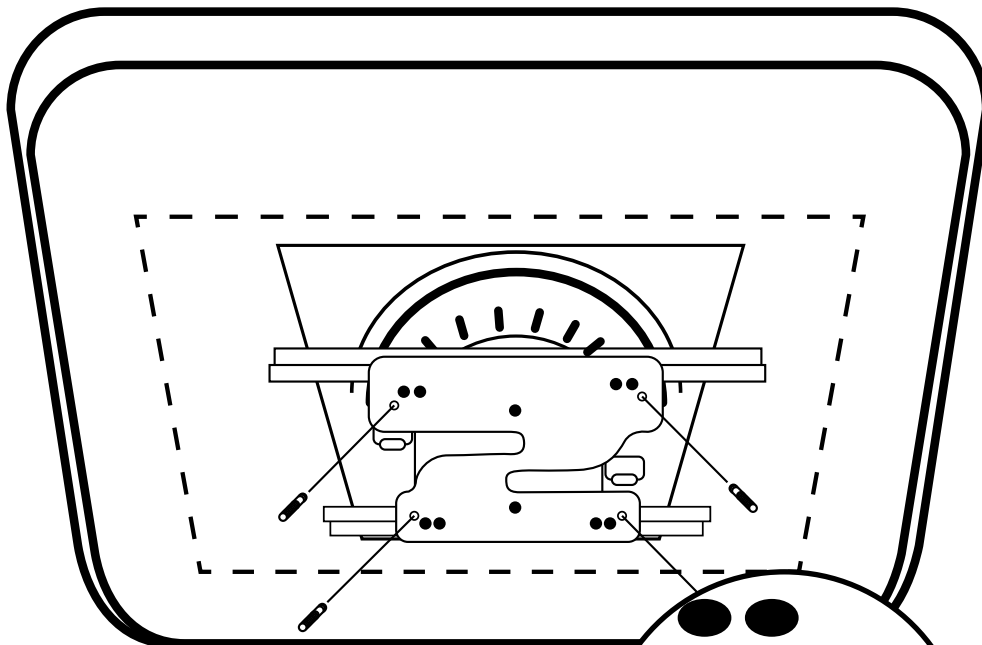

9

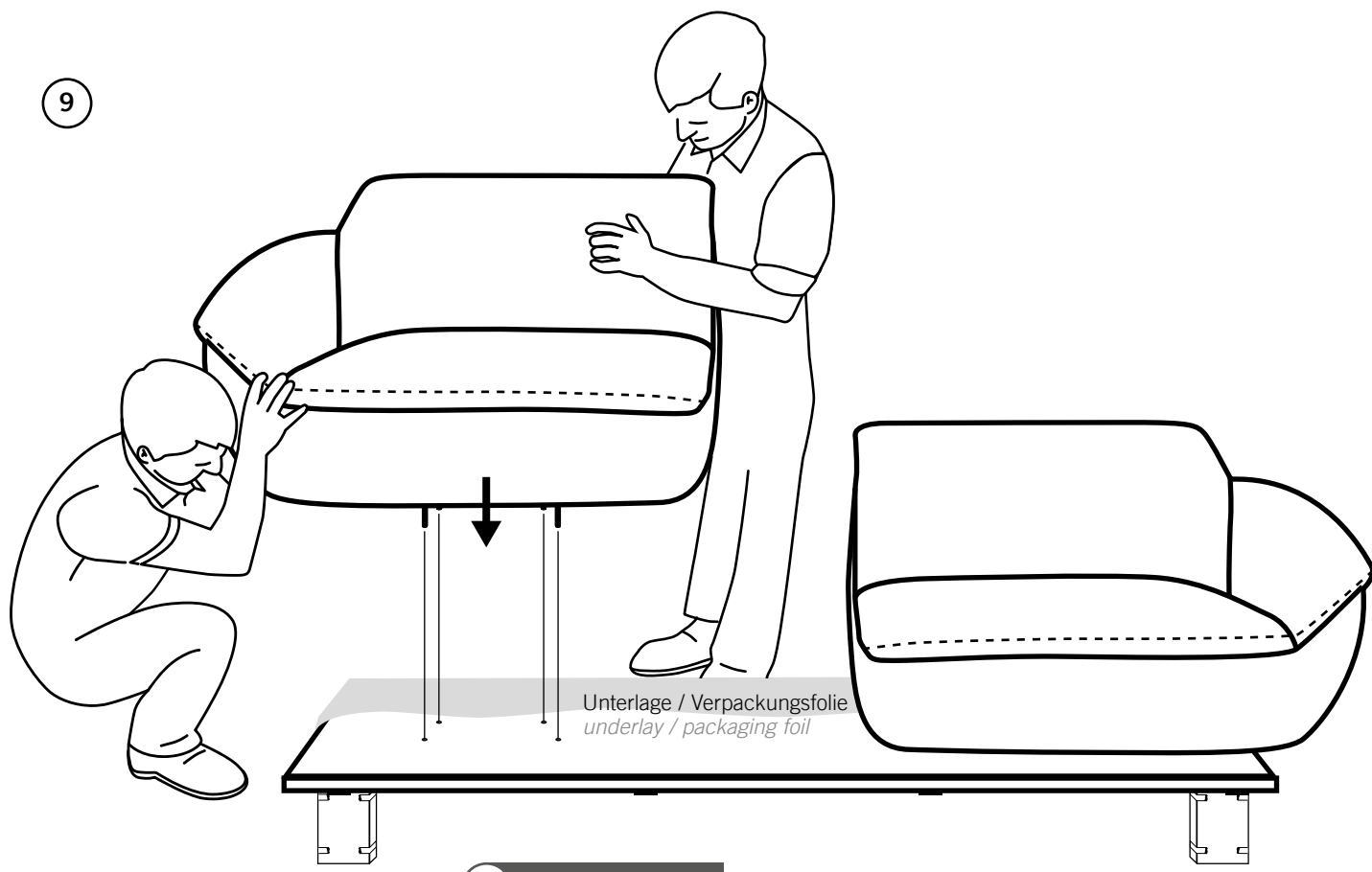

! Hinweis / Note:

Das Plateau ist kratzempfindlich.
Bitte vorsichtig behandeln. Bei der Sitzmontage Verpackungsfolie unterlegen!
*The plateau is sensitive to scratches.
Please handle with care. Bei der Sitzmontage Verpackungsfolie unterlegen!*

10

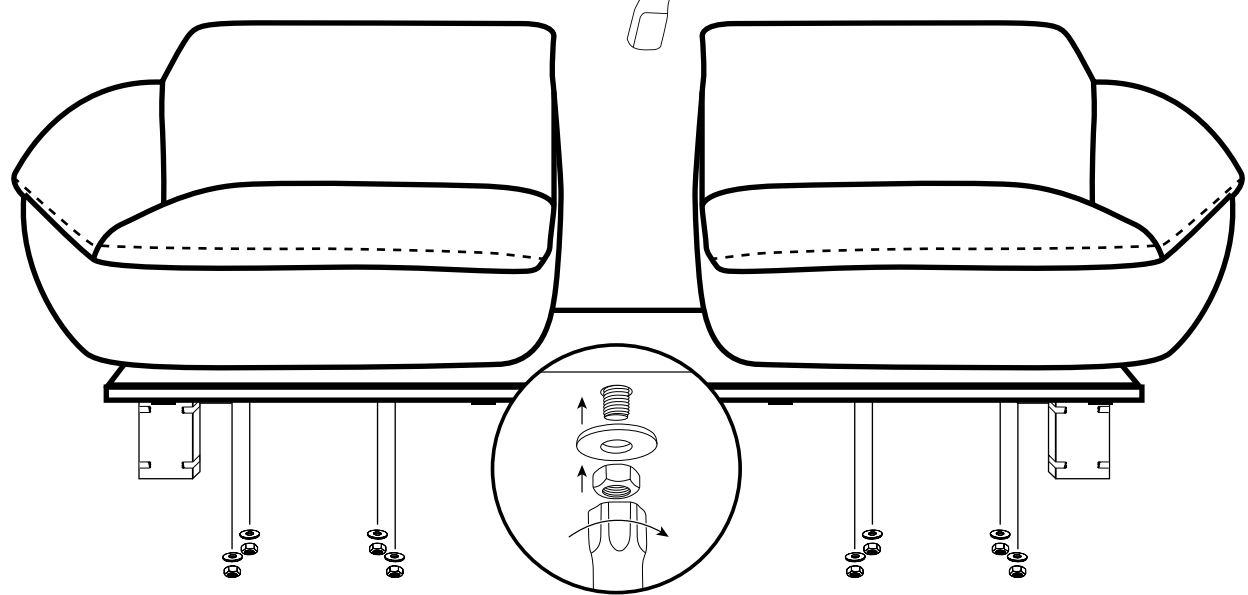
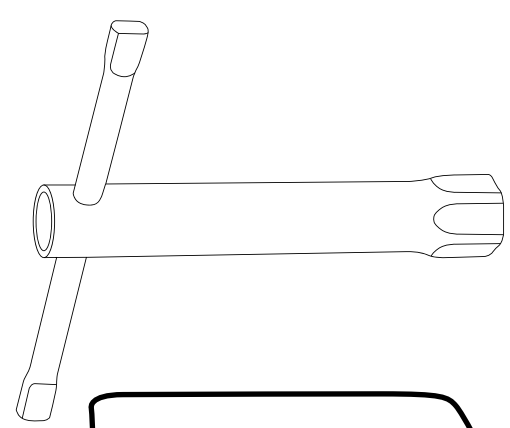

11

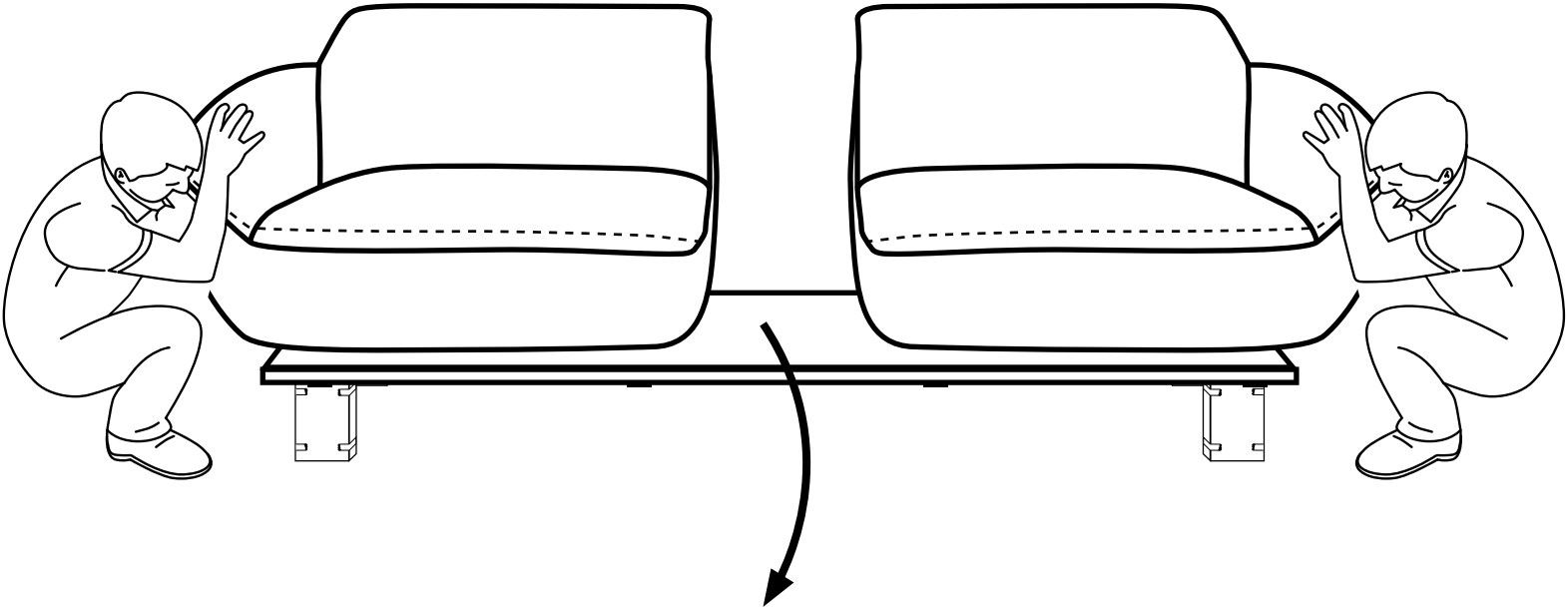

12

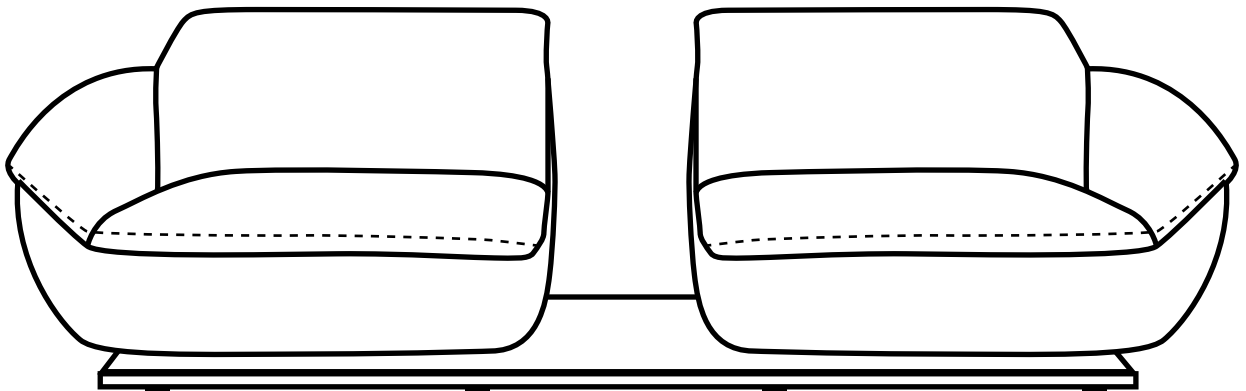

13 Funktionstest Drehfunktion (vorderer Hebel) / Functional test rotation (front lever)

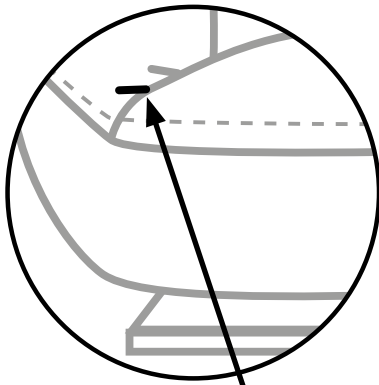

Vorderer Hebel
nach vorne ziehen:
Sitz drehbar
um 360°

Front lever
pull forward:
Seat can be
rotated 360°

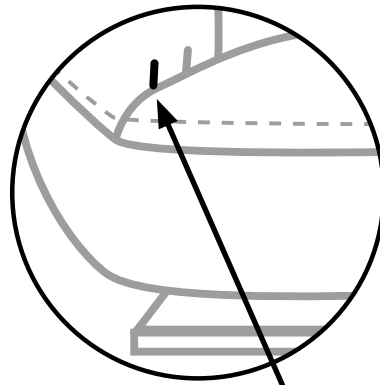

Vorderer Hebel
nach hinten ziehen:
Sitz ist fest

Front lever
pull backwards:
Seat is fixed

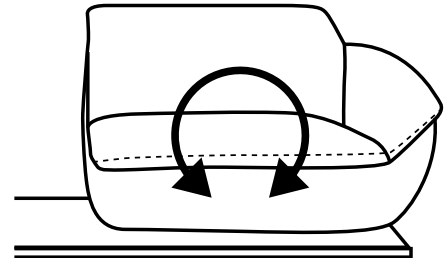

14 Funktionstest Schaukelfunktion (hinterer Hebel) / Functional test Rocking (rear lever)

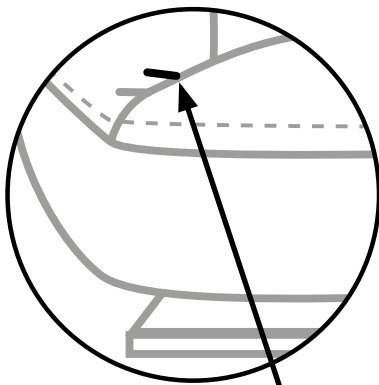

Hinterer Hebel
nach vorne ziehen:
stufenlose
Schaukelfunktion
aktiv

Rear lever
pull forward:
Stepless rocking
function active

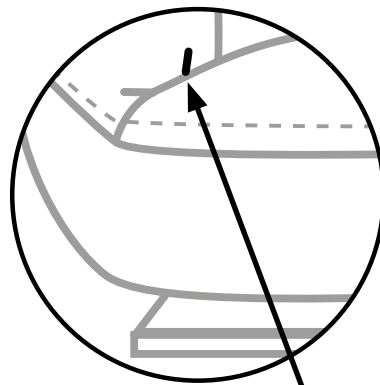

Hinterer Hebel
nach hinten ziehen:
Sitz ist fest

Rear lever
pull backwards:
Seat is fixed

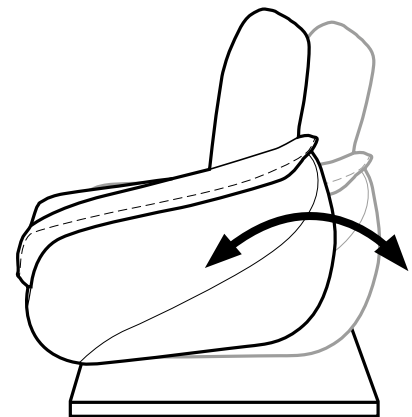

! Hinweis / Note:

Achtung! Überlastschutz!
Die Bremse löst sich bei Überlastung des Schaukelbeschlags.
Attention! Overload protection!
The brake releases if the swing bracket is overloaded.

15 Funktionstest Schieben / Functional test Sliding

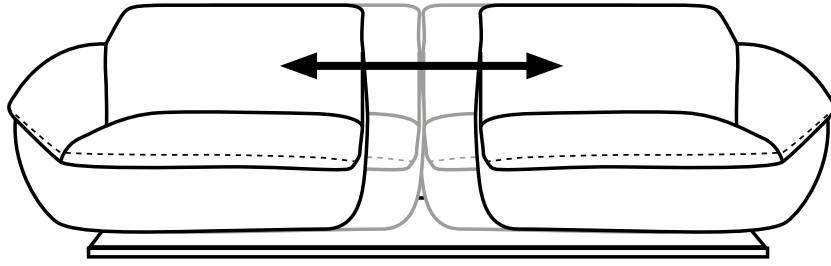

16 Funktionstest Kopfteil / Functional test headrest

