

femira.

FeMyDream



DE MONTAGEANLEITUNG
EN INSTALLATION INSTRUCTIONS
FR NOTICE DE MONTAGE
NL MONTAGEHANDLEIDING

DE **Symbolerklärung**
EN **Symbols used**

FR **Explication des symboles**
NL **Symboltoelichting**



DE **Achtung!** Wichtiger Hinweis zur Warnung vor Personen- oder Sachschäden.
EN **Warning!** Important information to warn of personal injury or material damage.
FR **Attention!** Remarque importante sur l'avertissement des dommages corporels ou matériels.
NL **Opgelet!** Belangrijke waarschuwing voor persoonlijk letsel of materiële schade.



DE **Achtung!** Wichtiger Hinweis zur Warnung vor Stromschlaggefahr.
EN **Warning!** Important information to warn of risk of electric shock.
FR **Attention!** Remarque importante sur l'avertissement du danger de choc électrique.
NL **Opgelet!** Belangrijke waarschuwing voor een elektrische schok.



DE Hinweis, Tip oder Verweis
EN Note, tip or reference
FR Remarque, conseil ou référence
NL Opmerking, tip of verwijzing



DE Detailhinweis
EN Detailed note
FR Remarque détaillée
NL Gedetailleerde instructie



DE Optional
EN Optional
FR En option
NL Optioneel

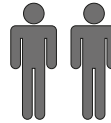

DE Montagepersonal
EN Assembly personnel
FR Personnel de montage
NL Montagepersoneel



DE Korrekte Montage
EN Correct installation
FR Montage correct
NL Correcte montage



DE Vor Montage überlegen
EN Consider before assembling
FR À déterminer avant le montage
NL Voor de montage bedenken



DE Falsche Montage
EN Incorrect installation
FR Montage incorrect
NL Verkeerde montage



DE Mit Kraftaufwand
EN With low physical effort
FR Nécessite de la force physique
NL Met krachtsinspanning



DE Schalter EIN / AUS
EN Switch ON / OFF
FR Interrupteur MARCHÉ/ARRÊT
NL Schakelaar AAN/UIT



DE Elektrisches Licht
EN Electric light
FR Éclairage électrique
NL Elektrisch licht

DE **Allgemeine Sicherheitshinweise und Informationen**
EN **General safety precautions and information**
FR **Consignes de sécurité et informations générales**
NL **Algemene veiligheidsvoorschriften en informatie**

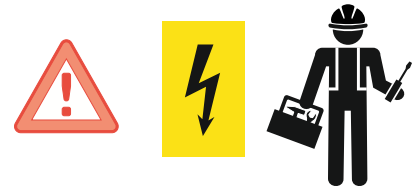

- DE Die Montage der Elektroanschlüsse ist grundsätzlich nur von autorisiertem Fachpersonal vorzunehmen. Vor der Verkabelung motorischer Komponenten ist sicherzustellen, dass die Leitungen spannungsfrei sind. Während der Verkabelung ist sicherzustellen, dass die Leitungen spannungsfrei bleiben (z. B. Wiedereinschalten verhindern). Der Hersteller übernimmt keine Haftung für Schäden, die durch unsachgemäßen Einsatz oder unsachgemäße Montage entstehen.
- EN Assembly of the electrical connections is only to be undertaken by an authorised professional. Before wiring ensure that the power lines are disconnected. During wiring, ensure that the power lines remain disconnected (e.g. cannot be reconnected). The manufacturer accepts no responsibility for any damage caused by inappropriate use or installation.
- FR Le montage des raccords électriques doit être effectué exclusivement par du personnel technique habilité. Avant le câblage, il convient de s'assurer que les câbles sont hors tension. Pendant le câblage, il convient de s'assurer que les câbles restent hors tension (par ex., éviter toute remise sous tension). Le fabricant décline toute responsabilité pour les éventuels dommages découlant d'une mise en œuvre ou d'un montage incorrects.
- NL De elektrische aansluitingen mogen uitsluitend door hiervoor bevoegd vakpersoneel worden uitgevoerd. Voordat kabels worden aangesloten, controleren dat deze spanningsvrij zijn. Gedurende het aansluiten van kabels ervoor zorgen dat deze spanningsvrij blijven (bijv. opnieuw inschakelen voorkomen). De producent kan niet aansprakelijk worden gesteld voor schade die door onjuist gebruik of een onjuiste montage ontstaat.



- DE **Schutz vor Verschmutzung während der Montage**
Bei der Fertigung Ihres Bettes wurde mit Sorgfalt jede Verschmutzung der Teile vermieden. Wir empfehlen Ihnen beim Aufbau Handschuhe zu tragen. So kann die Verschmutzung der wertvollen Bezugsstoffe verhindert werden. Viel Vergnügen mit Ihrem neuen Bett!
- EN **Protect against dirt while assembling**
Every care was taken during the manufacture of your bed to prevent the parts from getting dirty. Please wear gloves while assembling the bed, or ensure that any specialist fitters do the same. This will prevent soiling of the valuable cover fabrics. We hope you enjoy your new bed!
- FR **Protection contre la saleté pendant le montage**
Lors de la fabrication de votre lit tapissé, toutes les pièces ont soigneusement été protégées de la saleté. Veuillez porter des gants pendant le montage ou demandez au personnel technique en charge de le faire de les porter. Vous éviterez ainsi de salir les précieuses housses textiles. Nous vous souhaitons beaucoup de Plaisir avec votre nouveau lit tapissé !
- NL **Bescherming tegen vervuiling tijdens de montage**
Bij de productie van uw gestoffeerd bed werd met uiterste zorgvuldigheid vermeden dat onderdelen vervuild raakten. Draagt u handschoenen a.u.b. bij het opbouwen of zorg ervoor dat het hiermee belaste vakpersoneel de handschoenen draagt tijdens het opbouwen. Op die manier kan vervuiling van de hoogwaardige bekleding worden voorkomen. Wij wensen u veel plezier met uw nieuwe gestoffeerd bed!

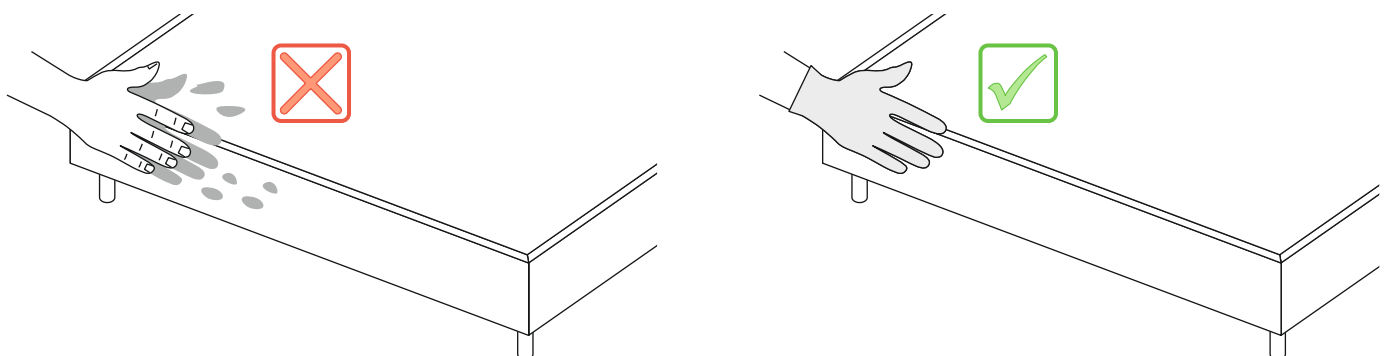

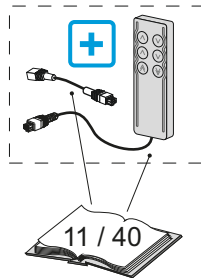
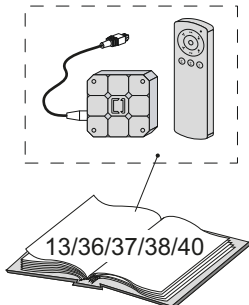
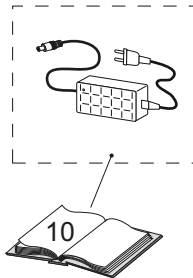
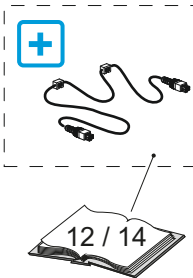
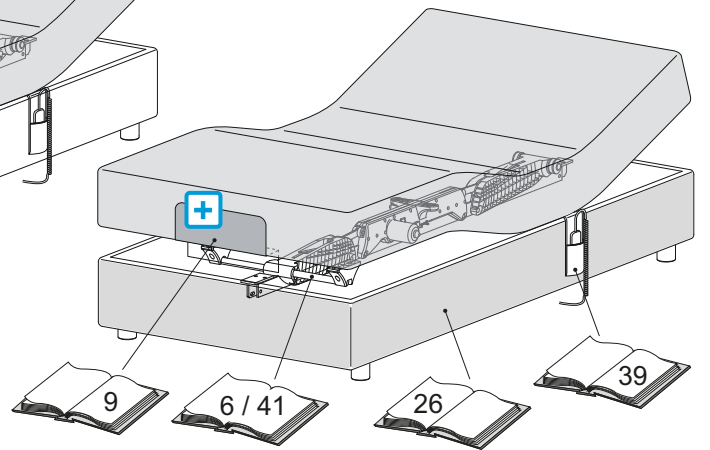
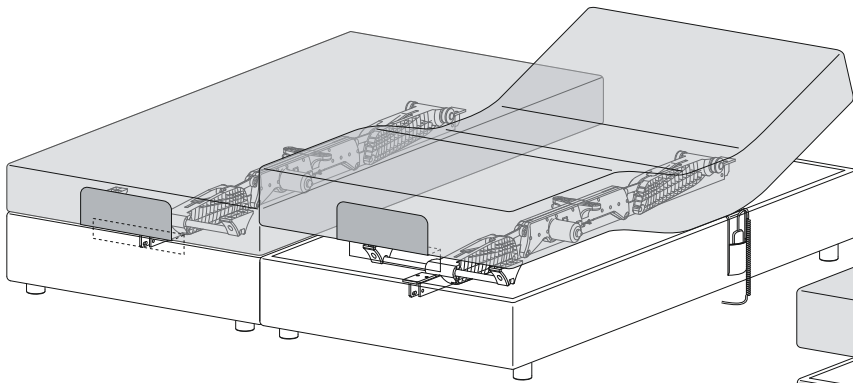
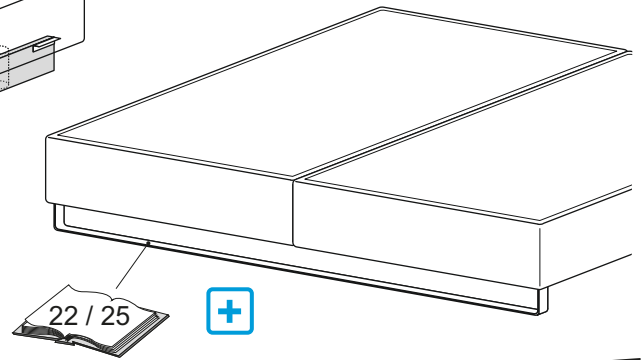
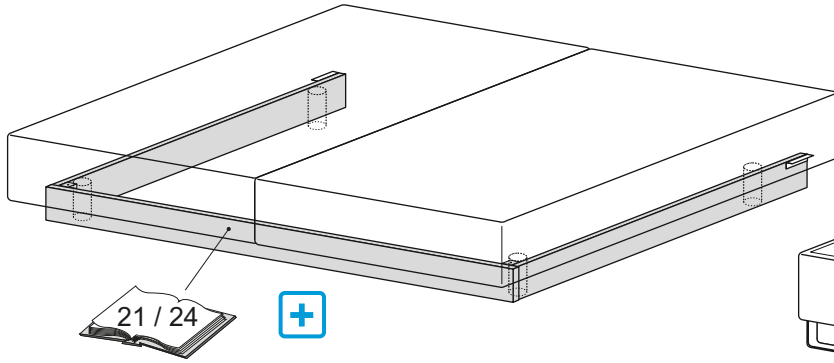
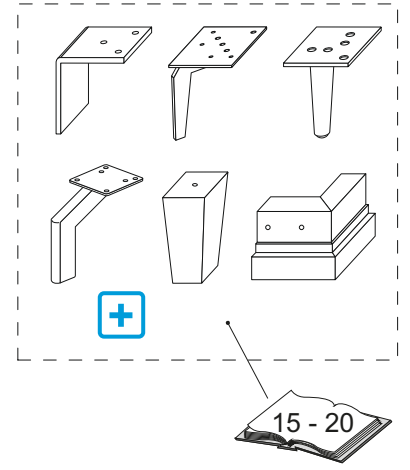
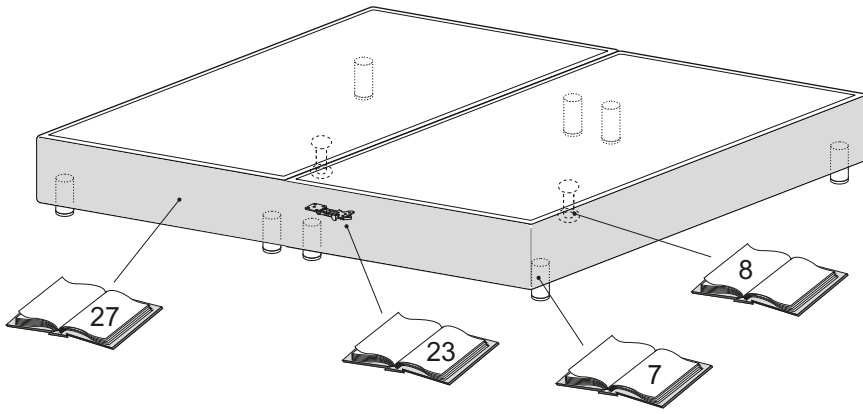

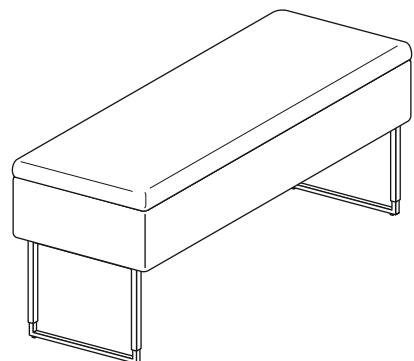
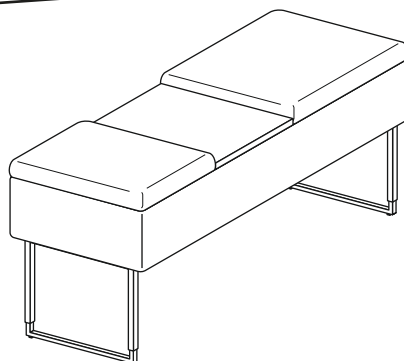
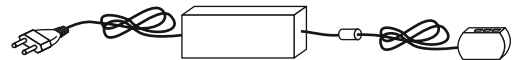
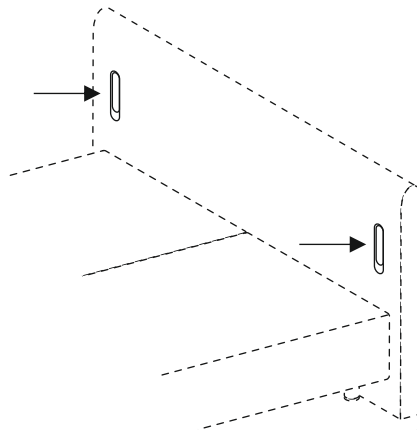
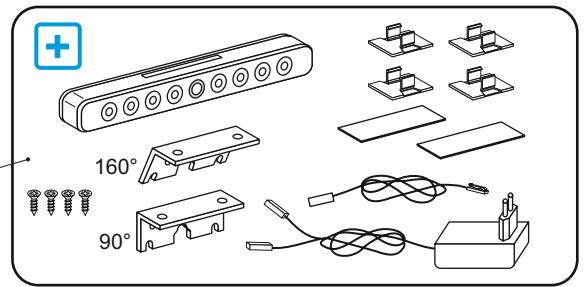
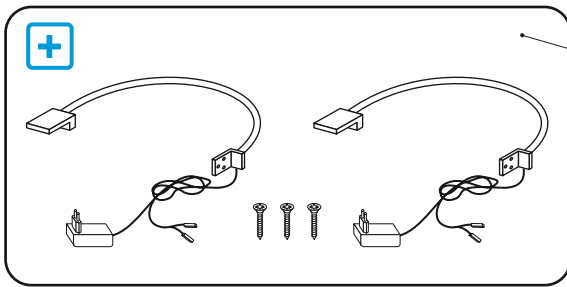
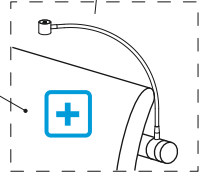
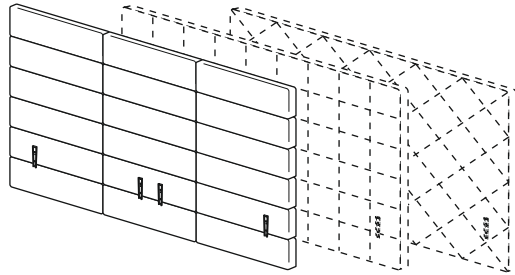
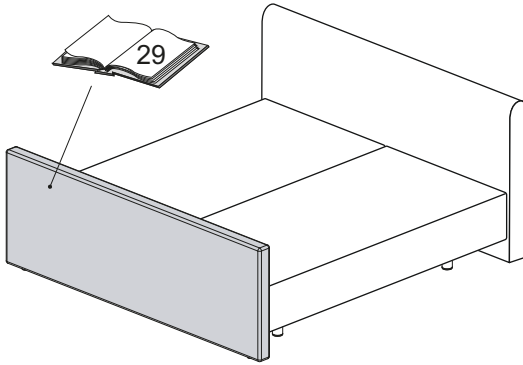
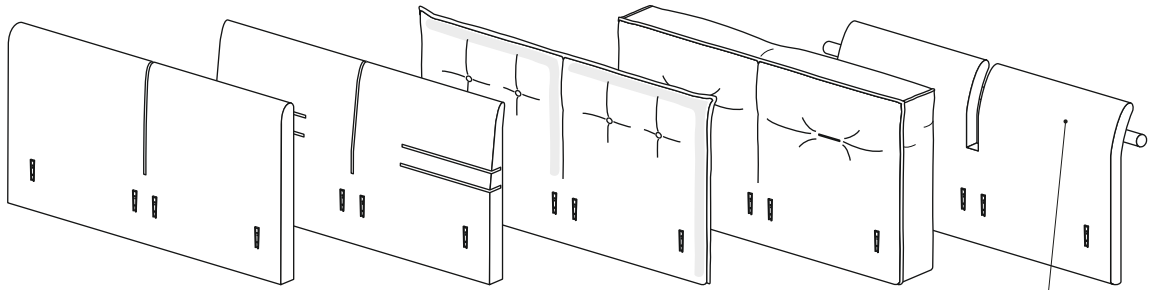

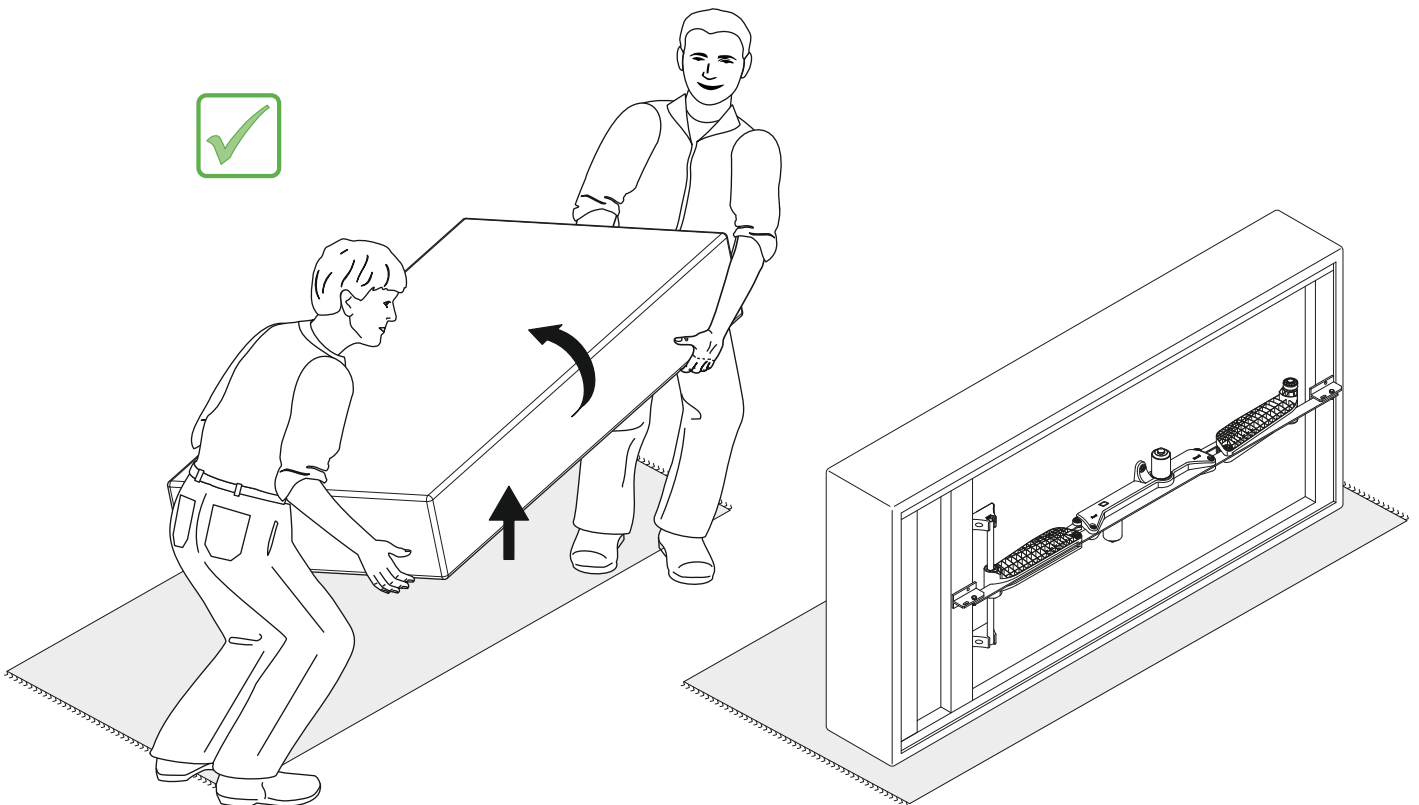
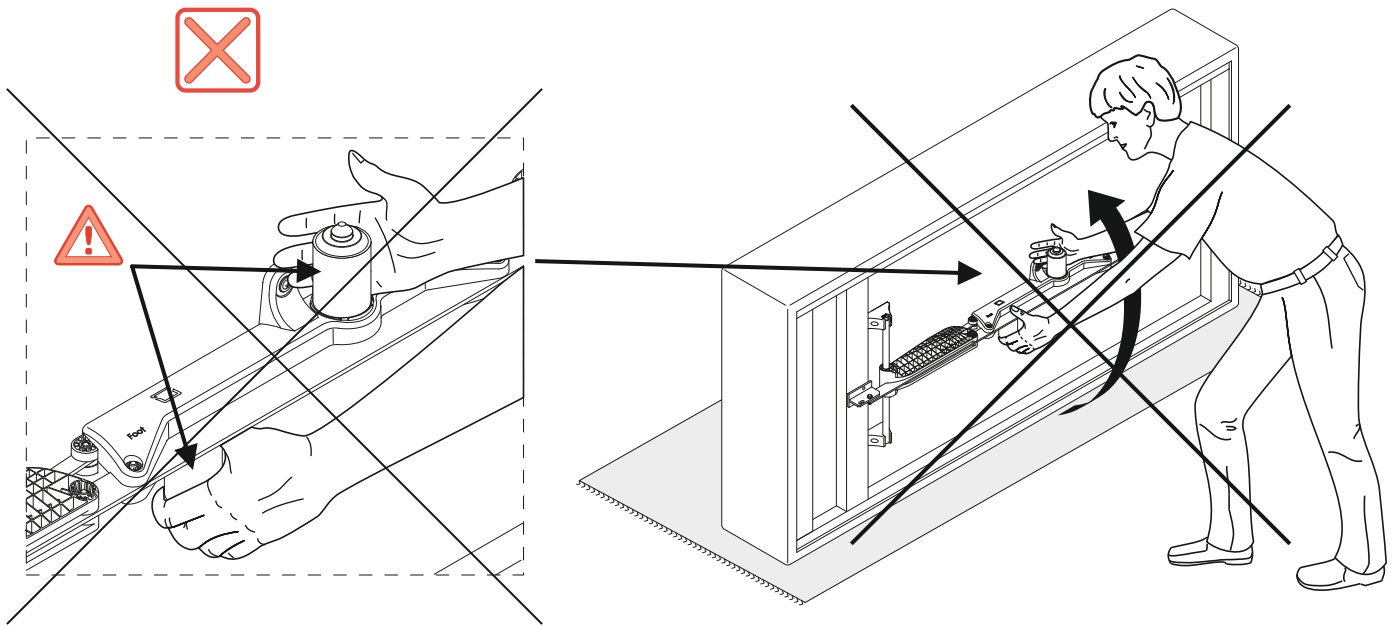
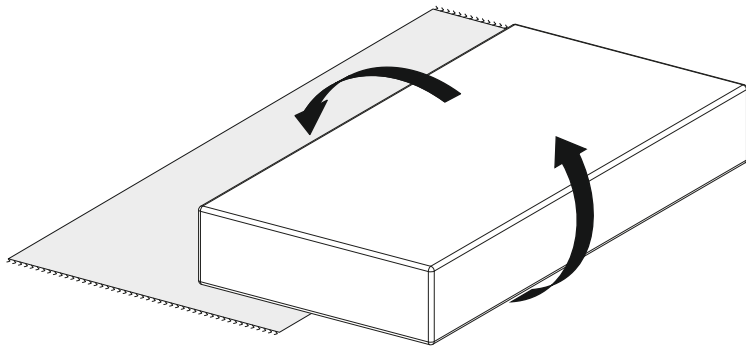

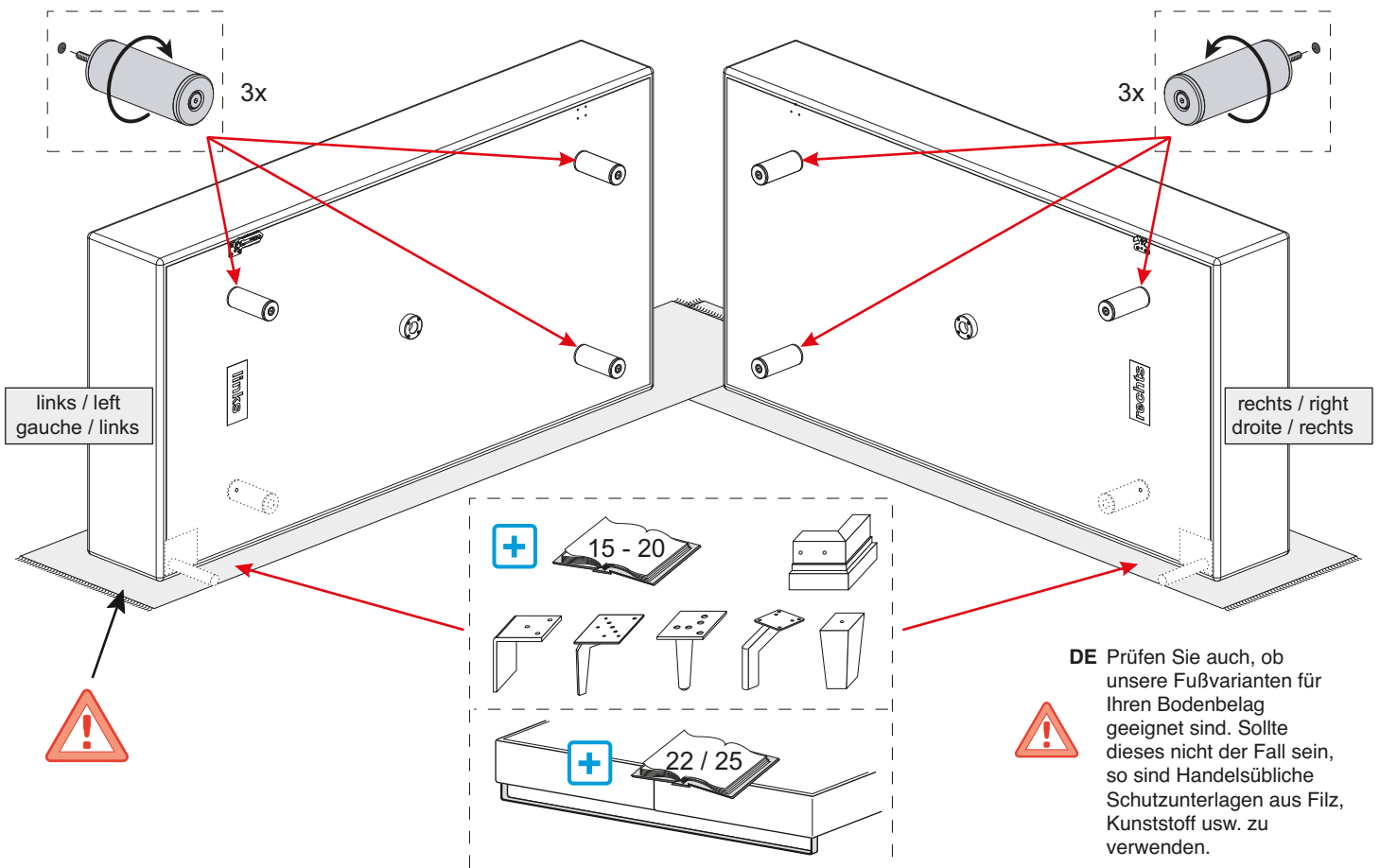
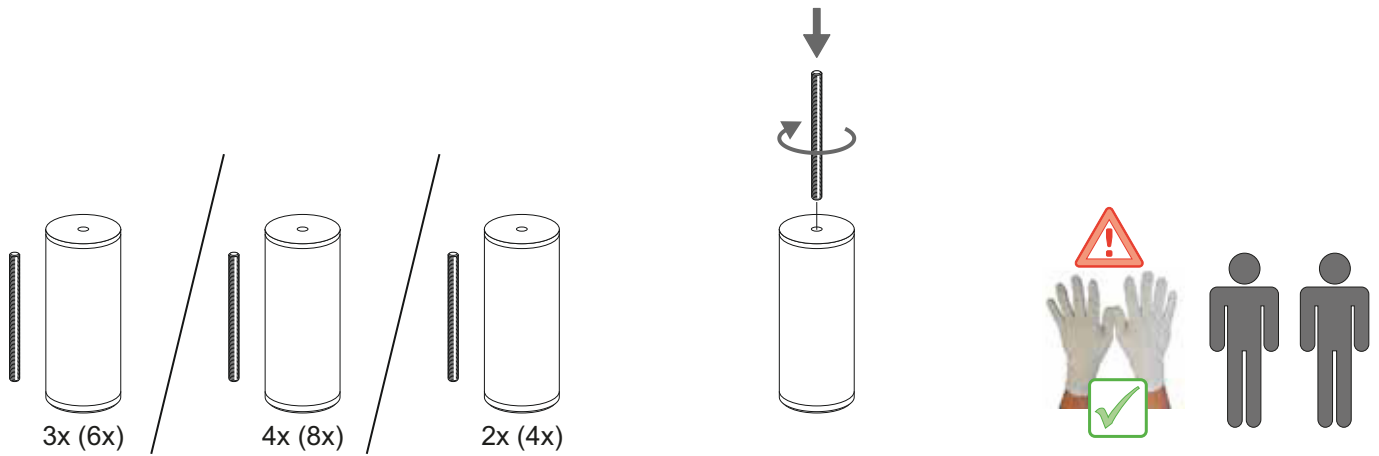

DE Prüfen Sie auch, ob unsere Fußvarianten für Ihren Bodenbelag geeignet sind. Sollte dieses nicht der Fall sein, so sind handelsübliche Schutzunterlagen aus Filz, Kunststoff usw. zu verwenden.

EN Make sure that our legs are suitable for your floor covering. If this is not the case, then please use standard commercially available protectors made of felt, plastic etc.

FR Vérifiez également que nos variantes de pieds conviennent pour votre revêtement de sol. Si tel n'est pas le cas, il convient d'utiliser des protections du commerce en feutre, matière synthétique, etc.

NL Controleert u ook of onze poten geschikt zijn voor uw vloer. Wanneer dat niet het geval is, moeten gangbare beschermingen van vilt, kunststof e.d. onder de poten worden gebruikt.

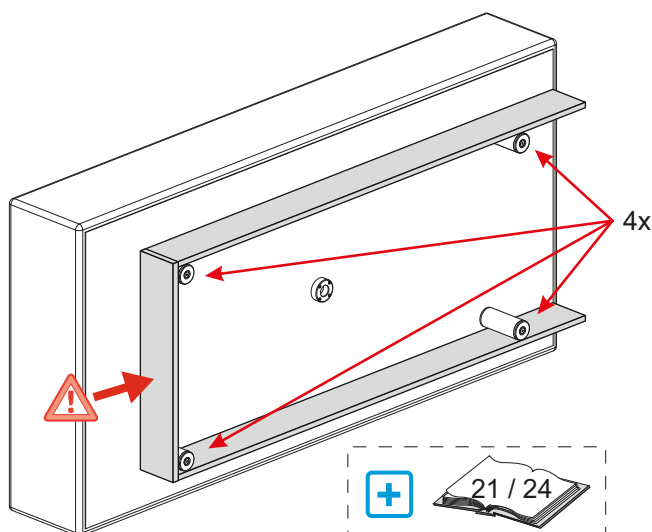

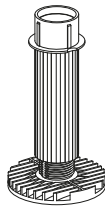

1x (2x)

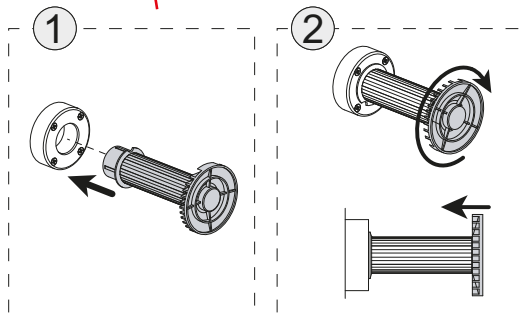
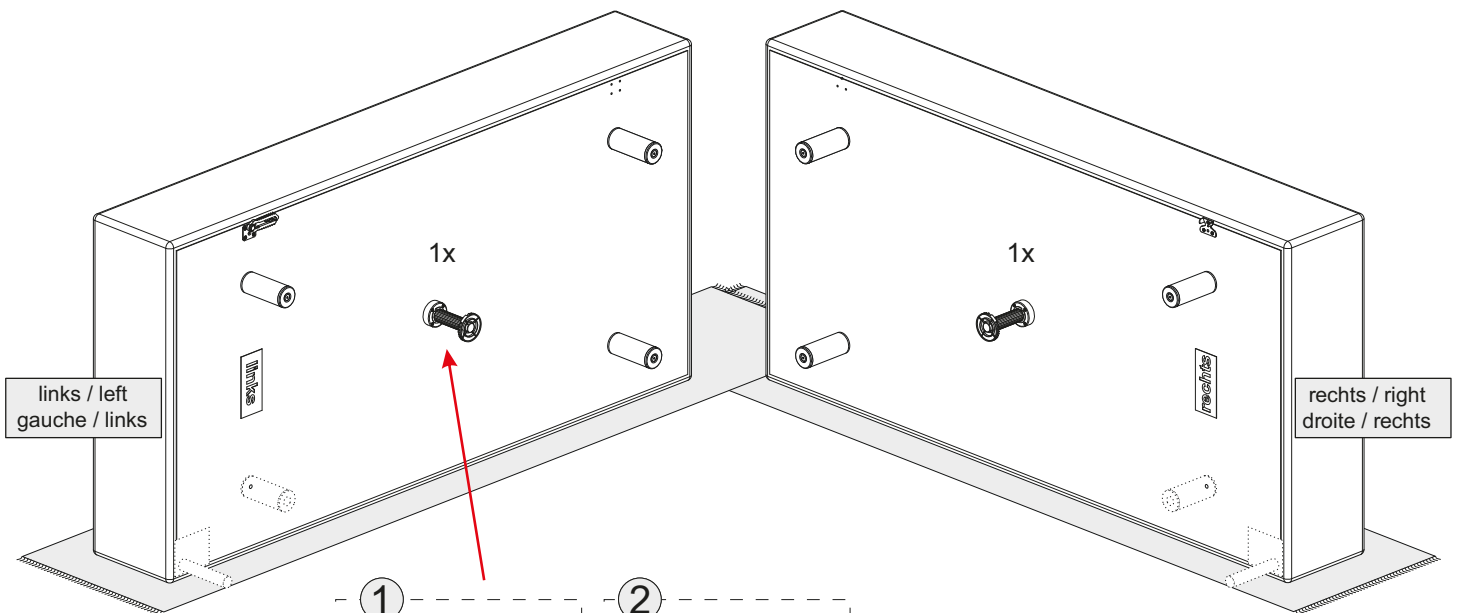

- DE** Schraubfüsse auf minimale Höhe eindrehen.
- EN** Insert screw feet to minimum height.
- FR** Visser les pieds jusqu'à la hauteur minimale.
- NL** Schroefpoten indraaien tot minimale hoogte.

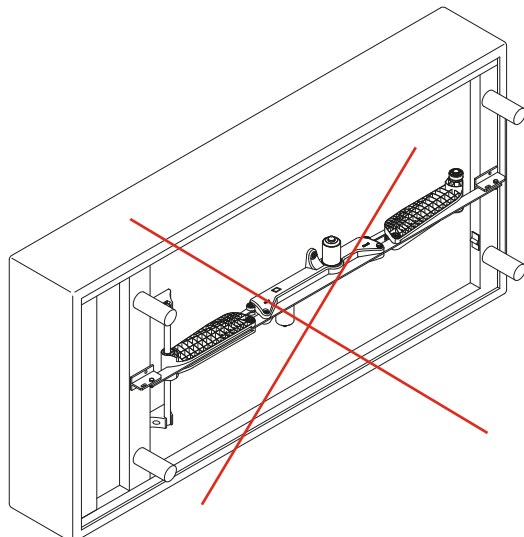

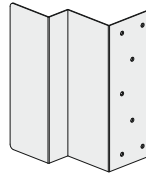
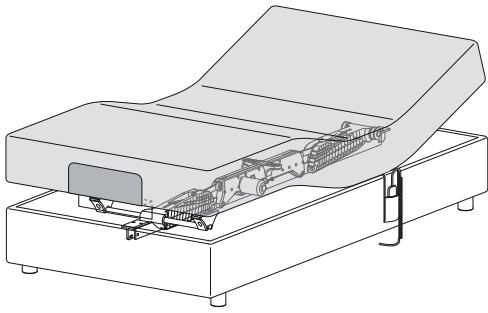

4,5x20

7x

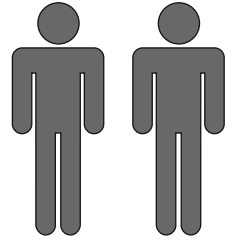
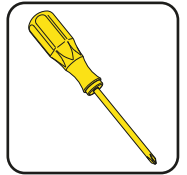

DE Vorsicht bei Demontage der Box und seitlicher Lagerung während der Montage!

GB Caution at disassembly of the box and sidelong storage during the assembly!

FR Attention au moment du démontage du sommier et l'entreposage latérale au moment de la montage!

NL Oppassen bij het uitpakken, demonteren en het zijwaarts neerzetten bij montage van de box!

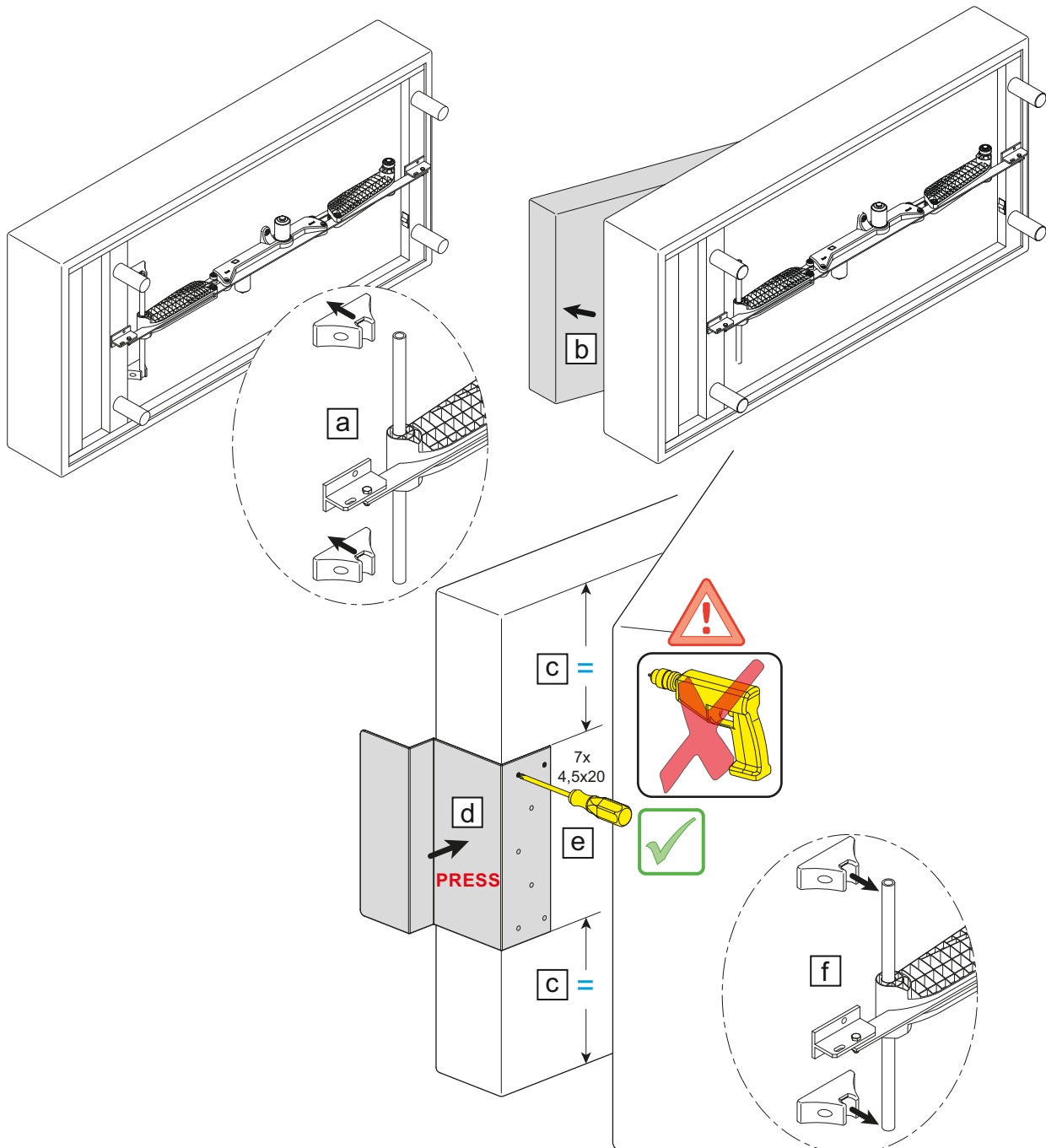

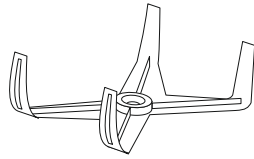
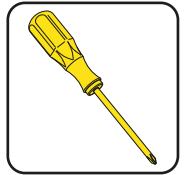
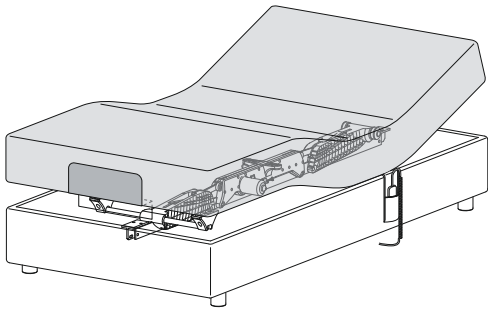

1 x



1 x

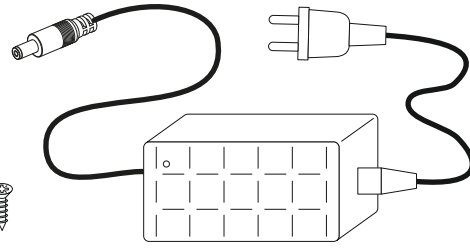

1 x

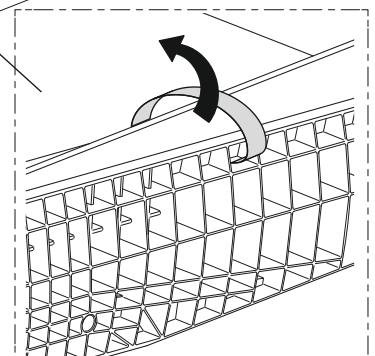
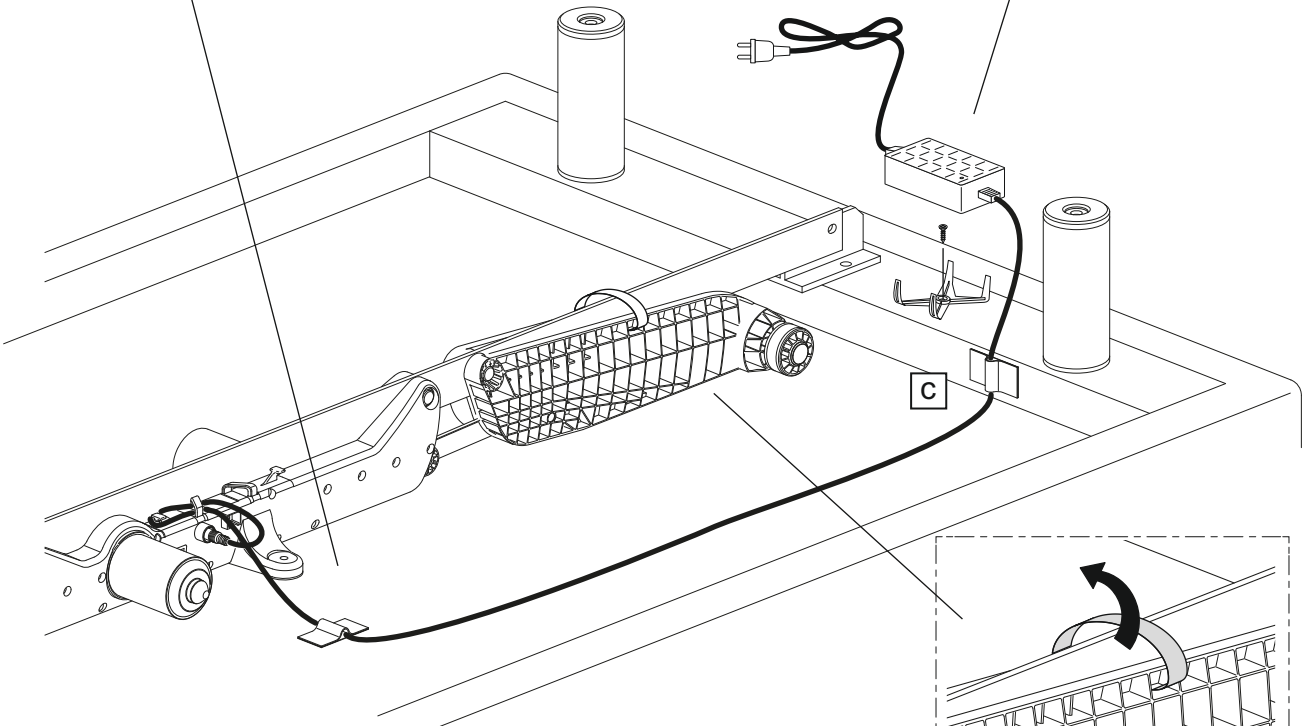
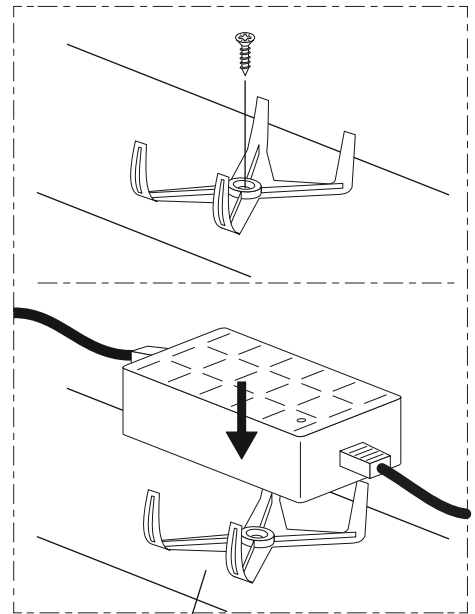
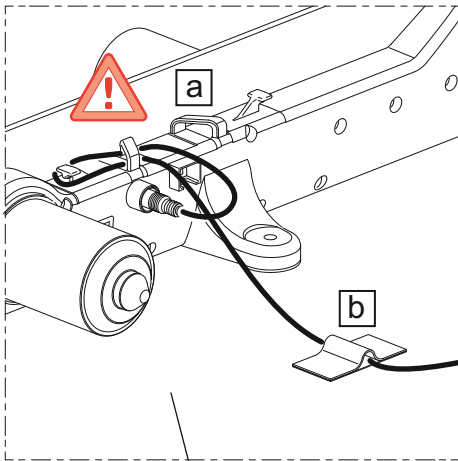

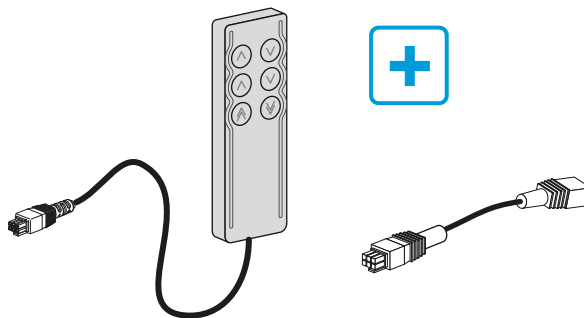
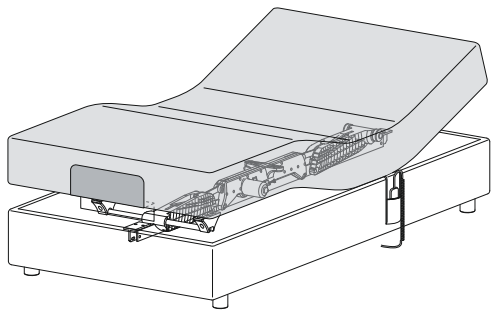

1 x

1 x

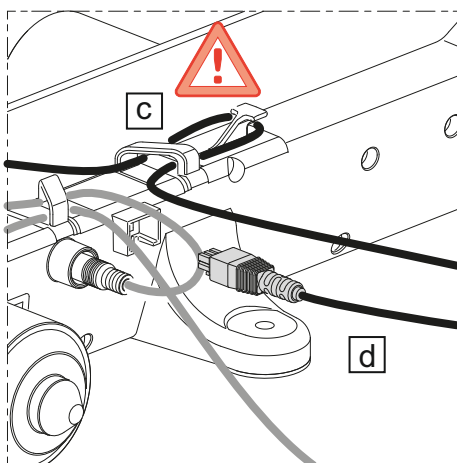
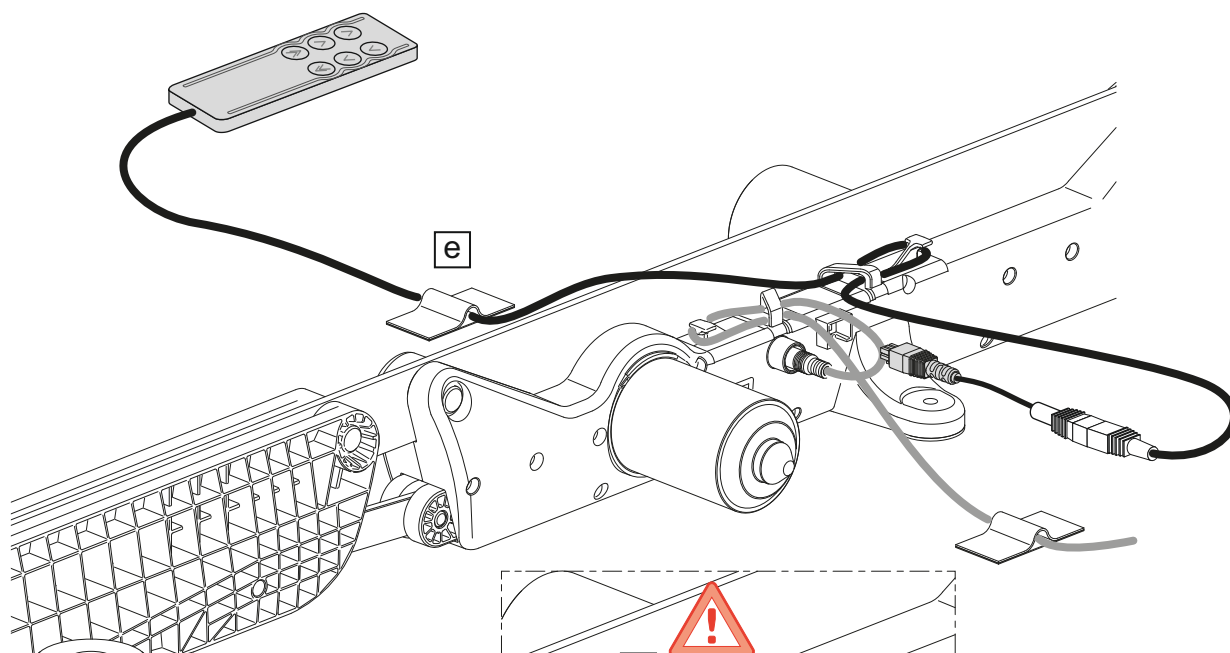
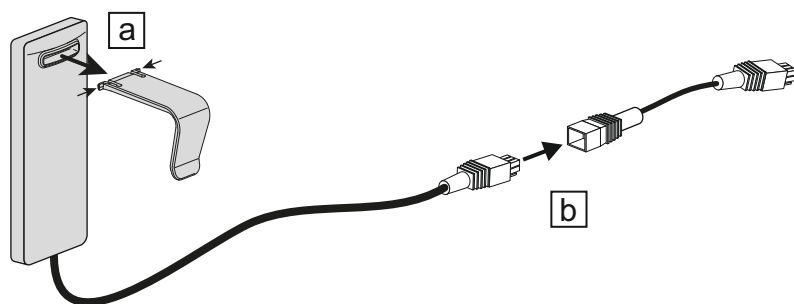

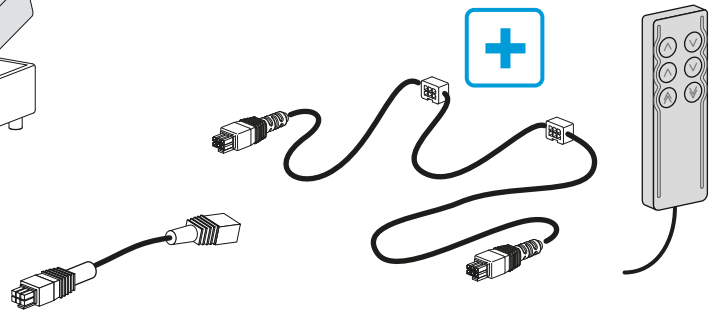
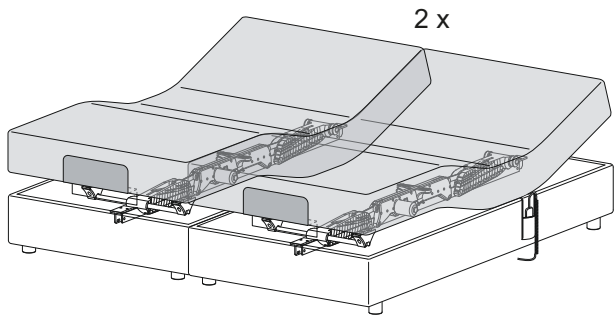

2x

1x

1x

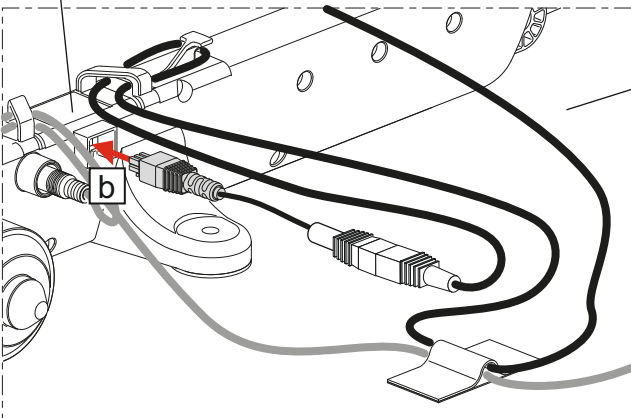
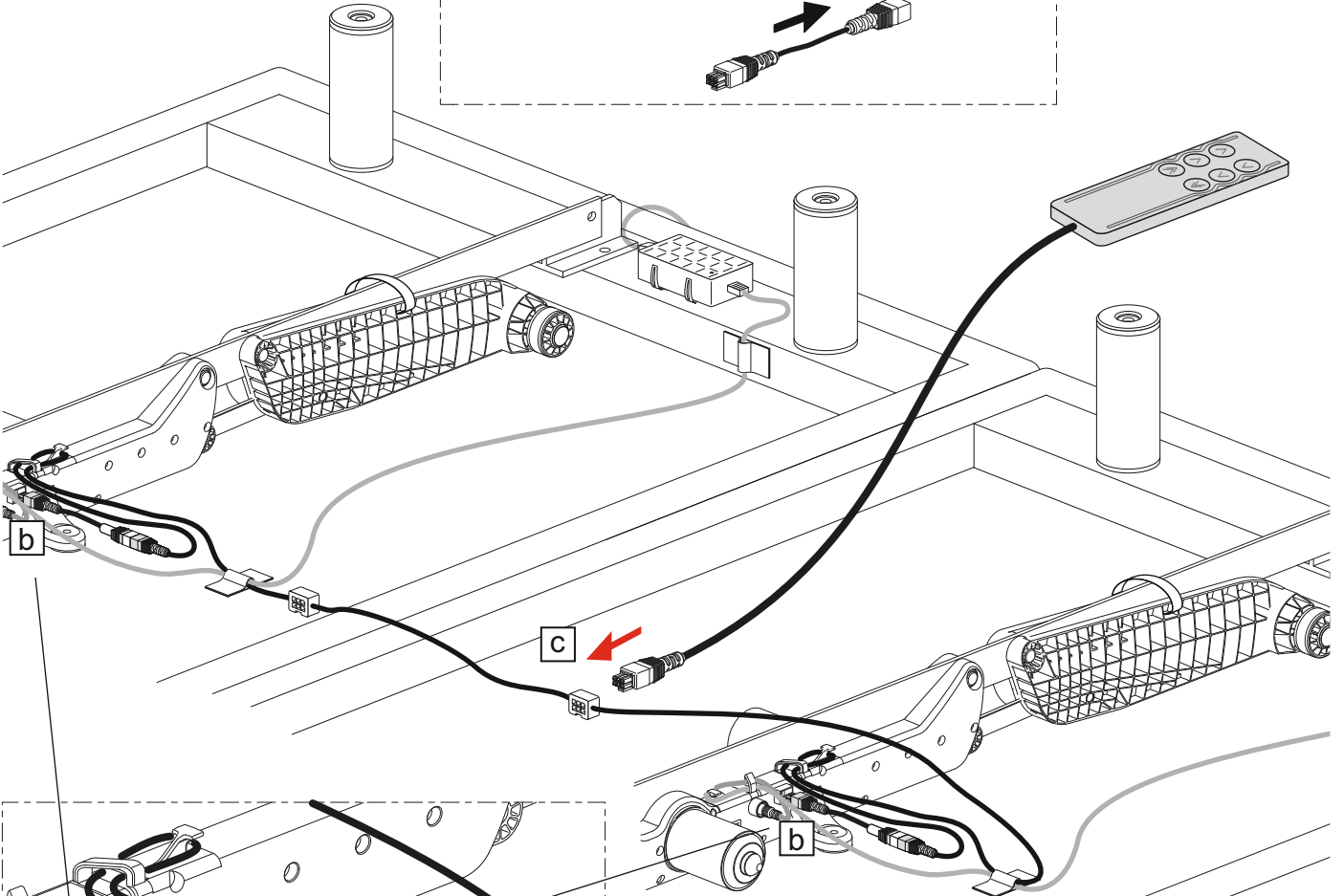
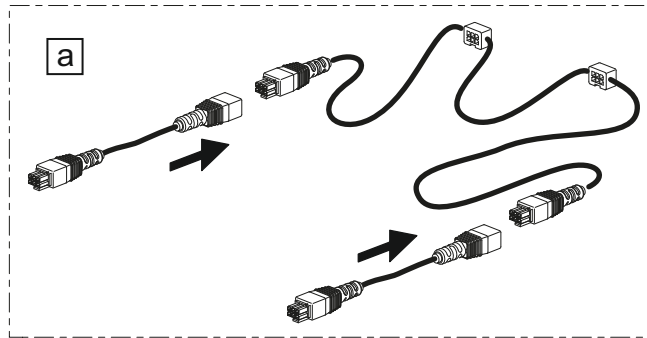

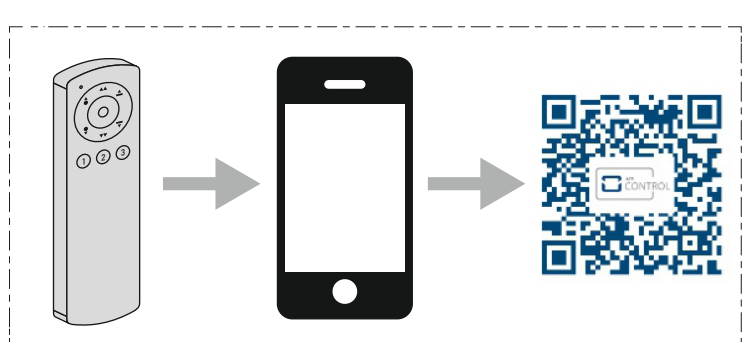
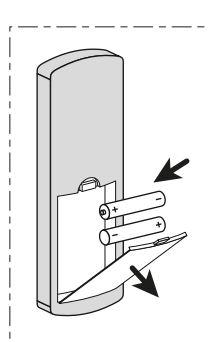
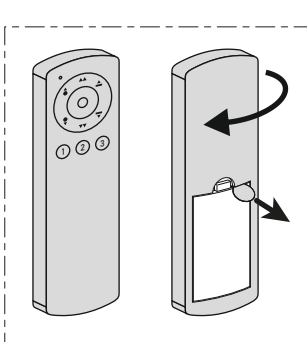
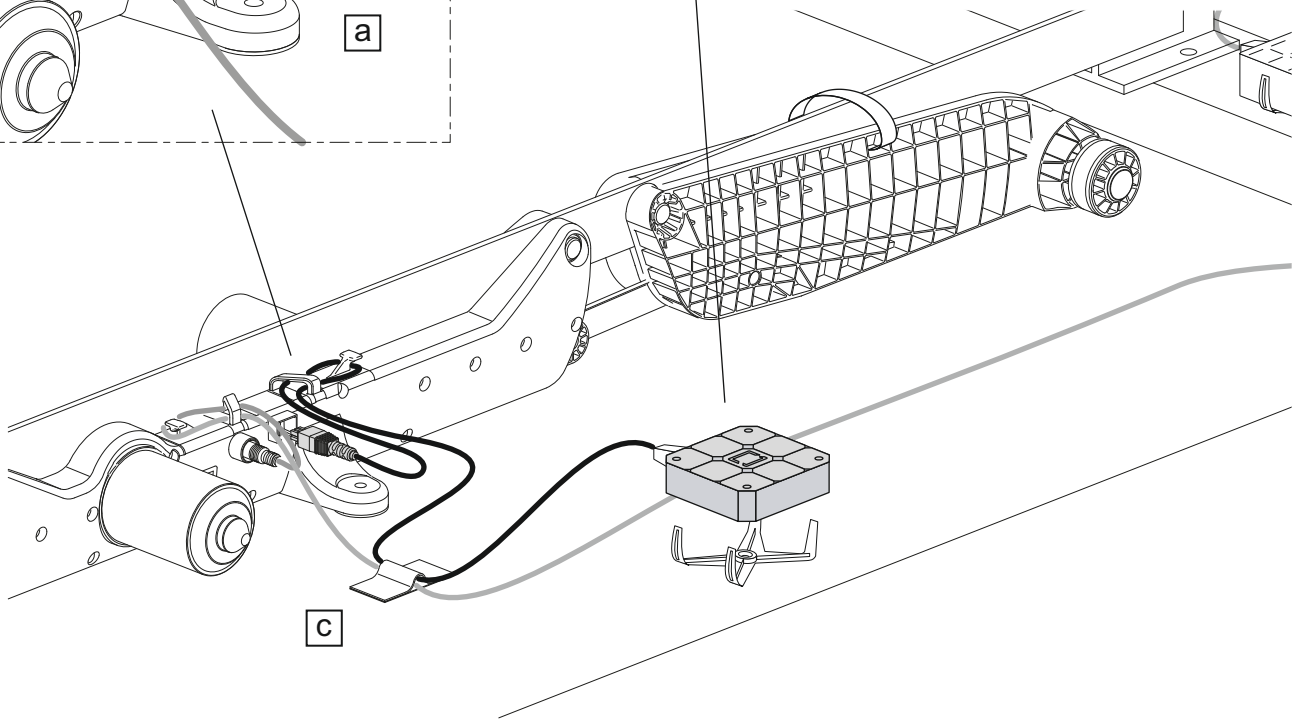
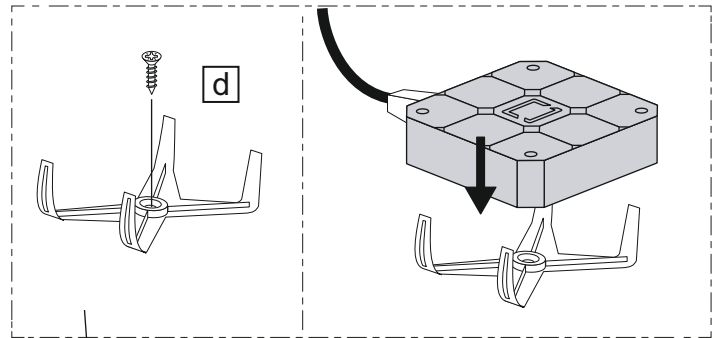
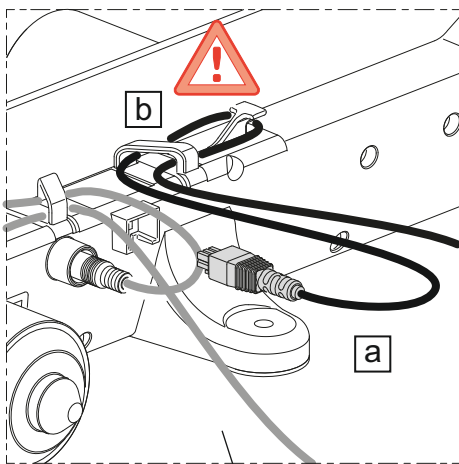
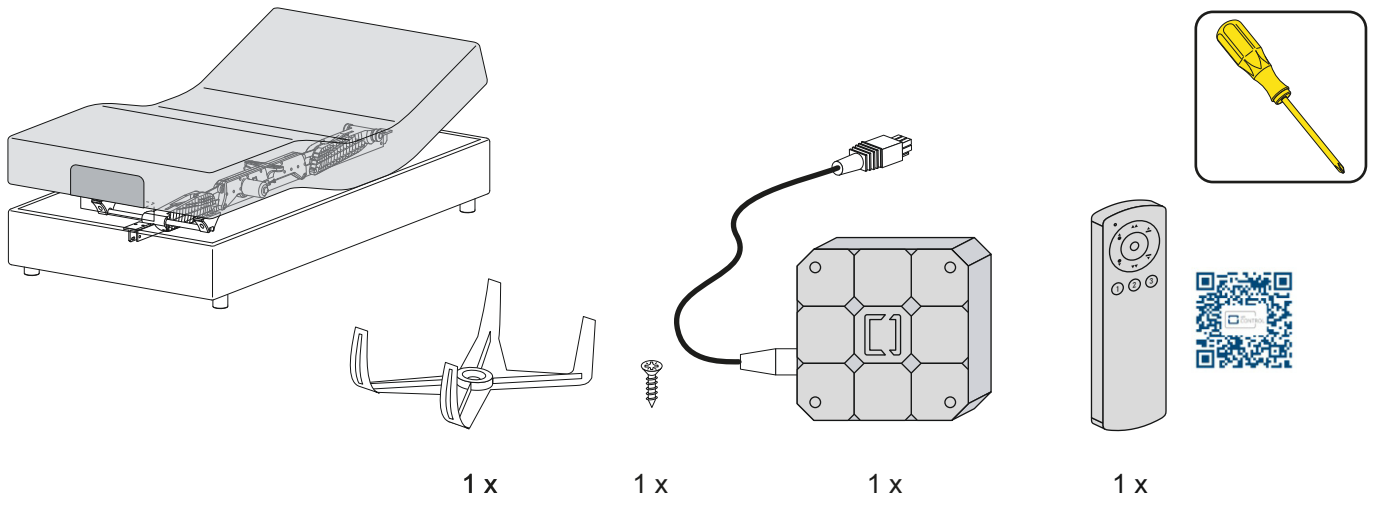

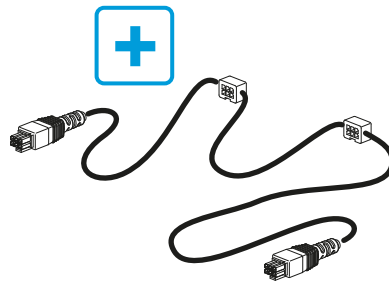
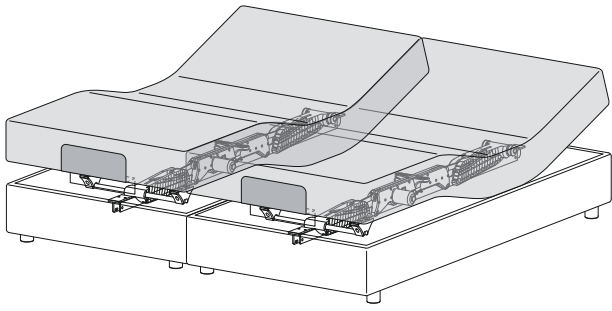

1x

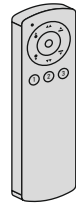

1x

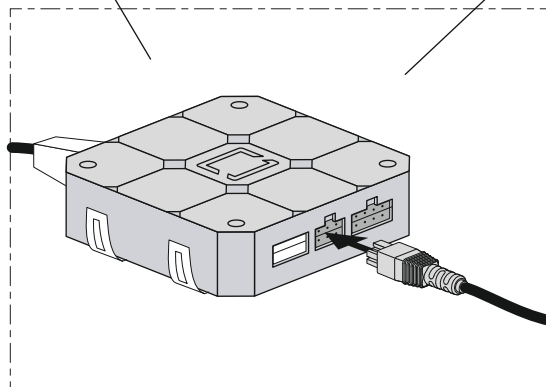
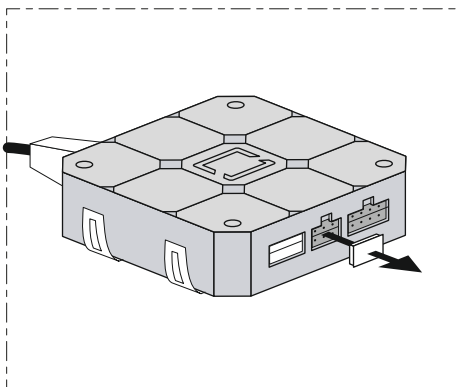
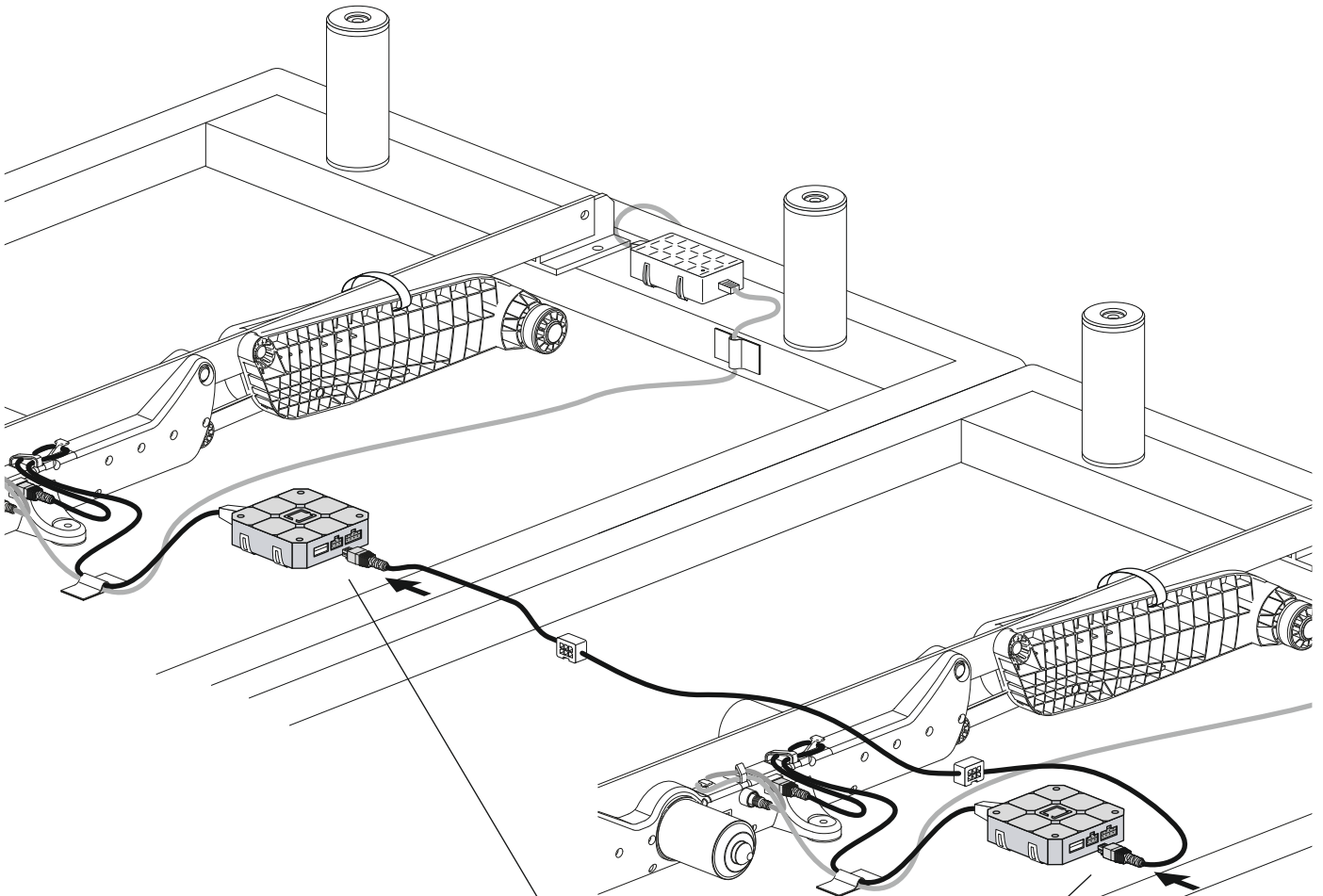

D1 1581678

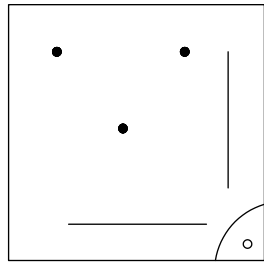
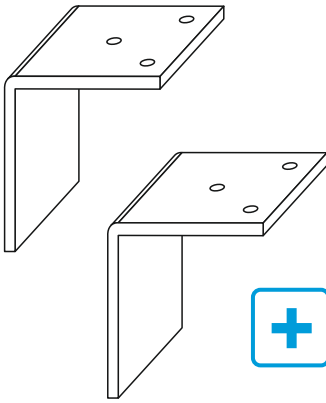

DE Bohrschablone
EN Drilling jig
FR Gabarit de forage
NL Boormal

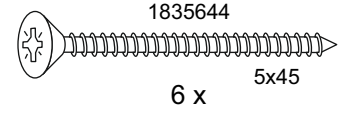
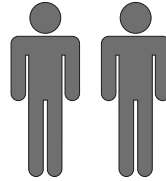
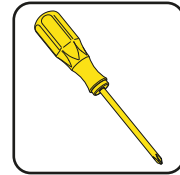
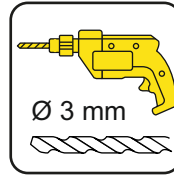

1

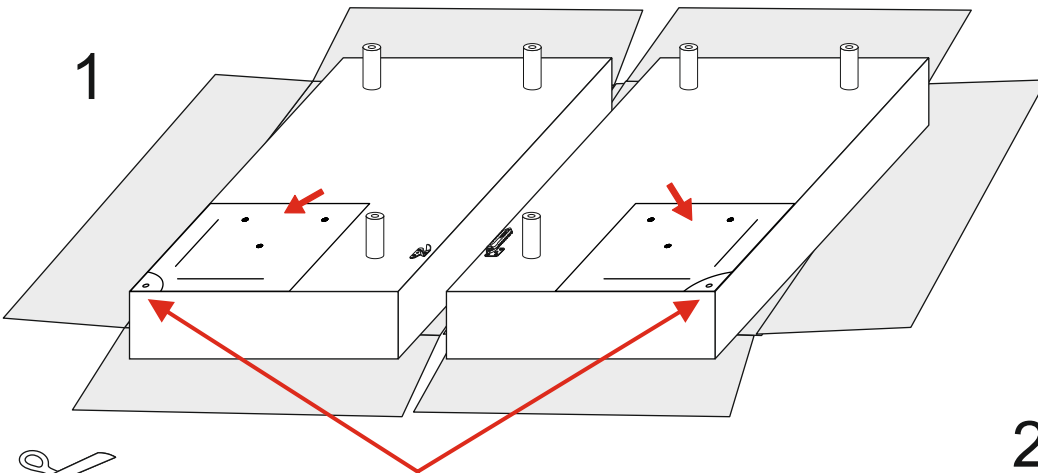

2

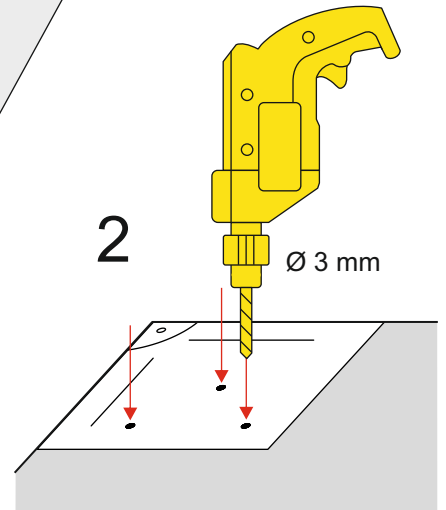

3

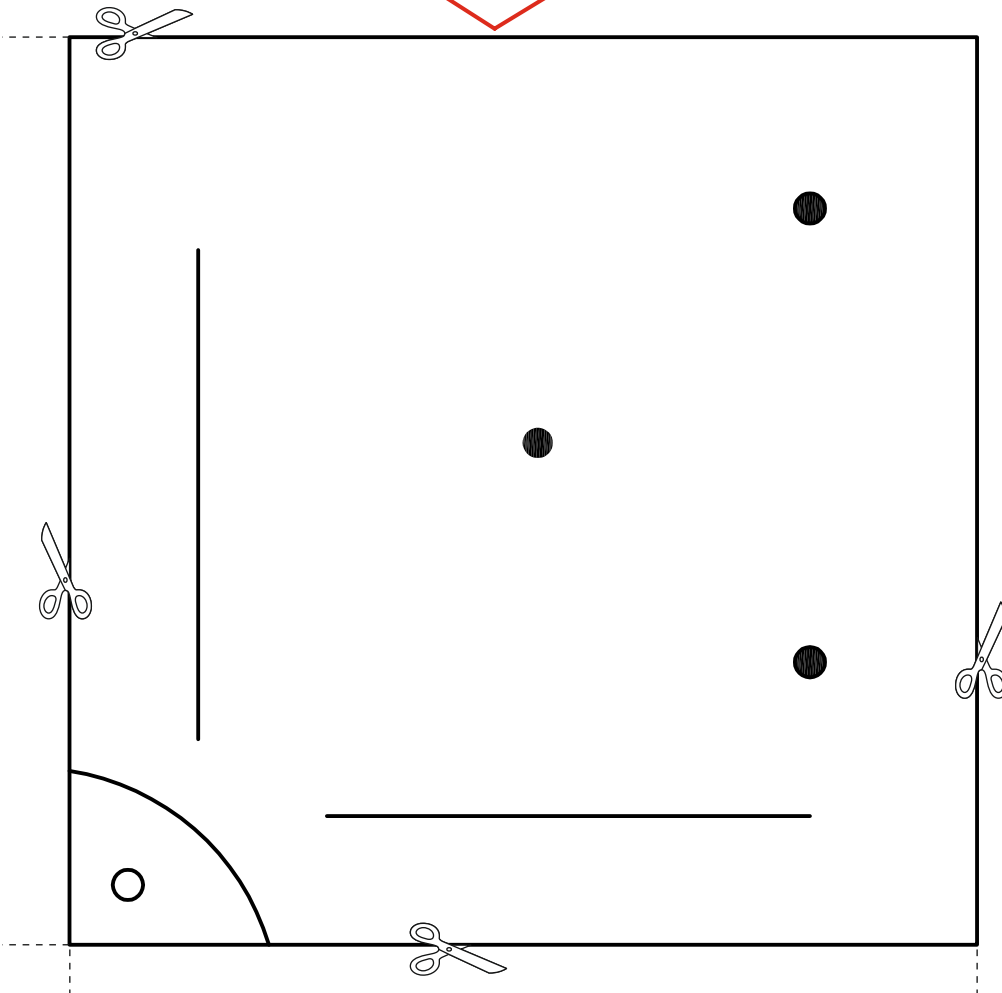
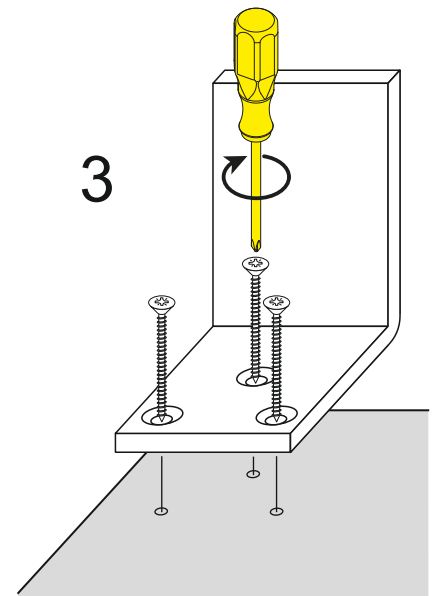

D2 1829414

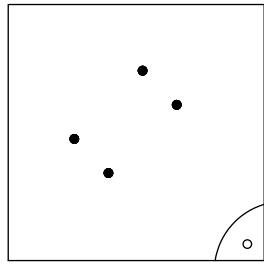
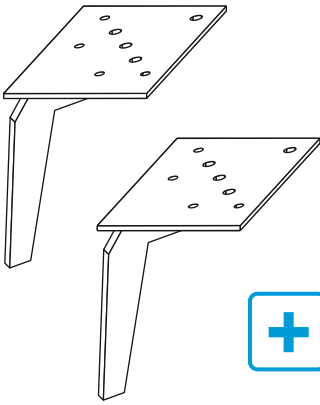

DE Bohrschablone
EN Drilling jig
FR Gabarit de forage
NL Boormal

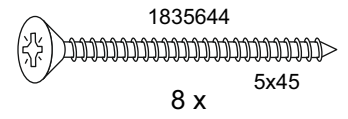
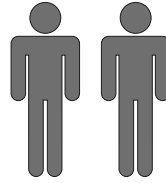
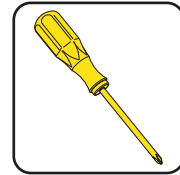
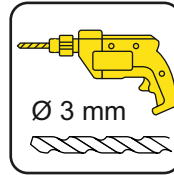

1

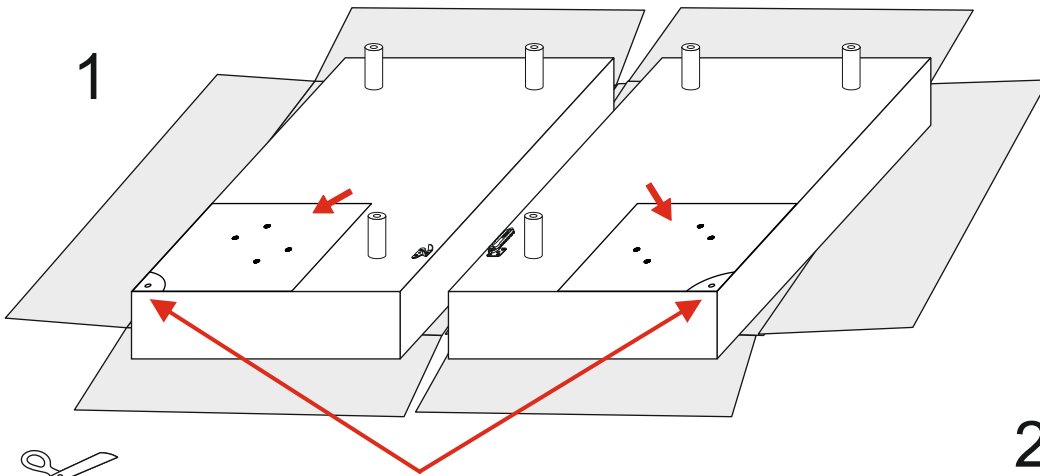

2

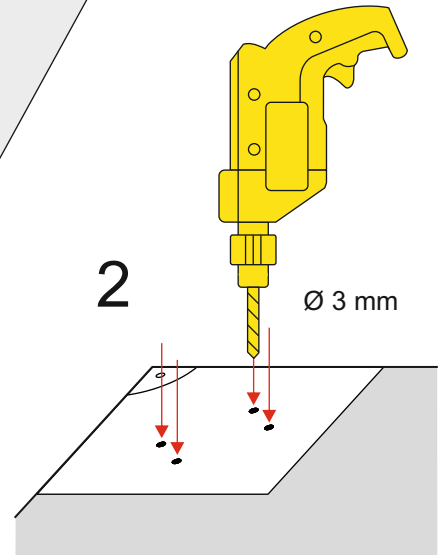

3

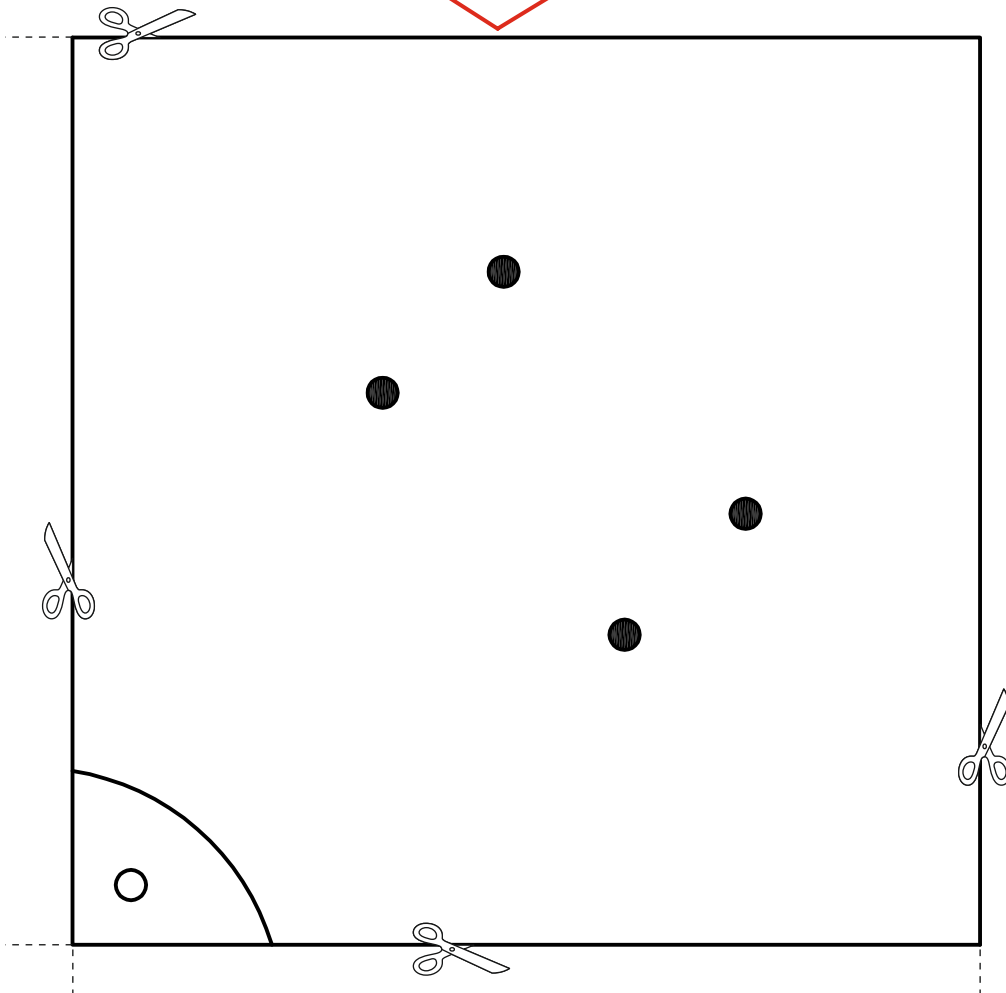
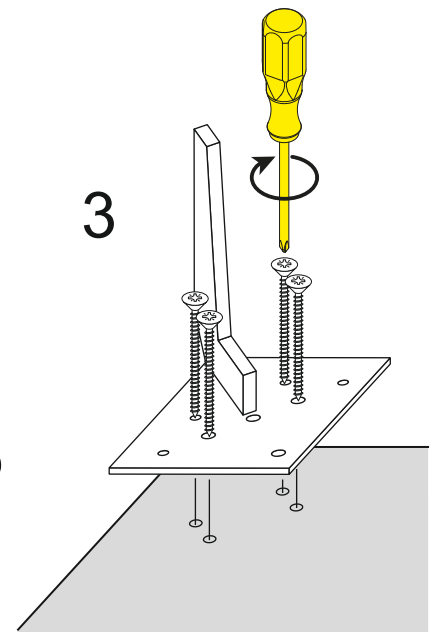

D5 1814802

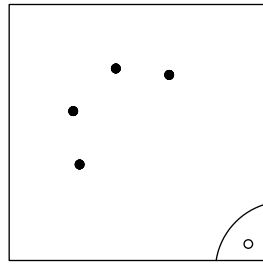
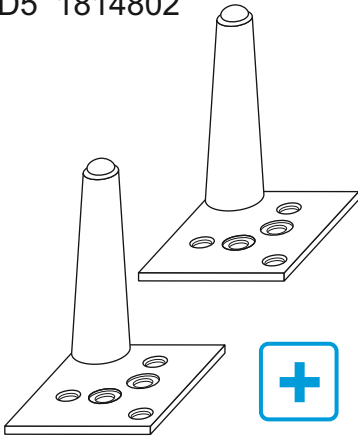

DE Bohrschablone
EN Drilling jig
FR Gabarit de forage
NL Boormal

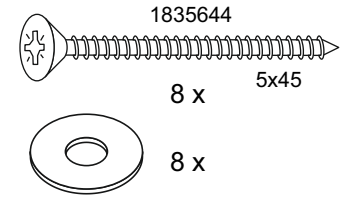
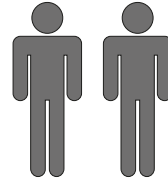
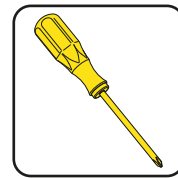
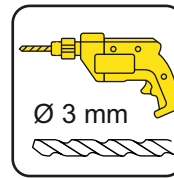

1

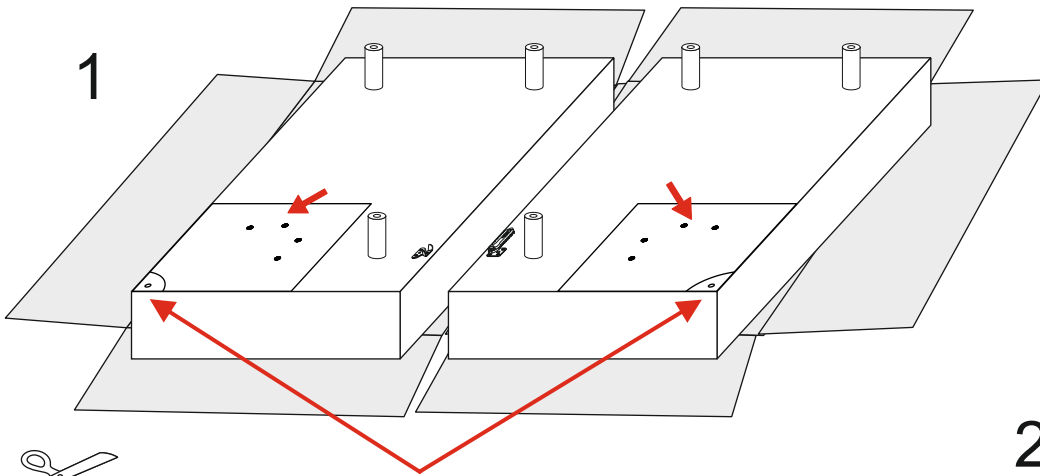

2

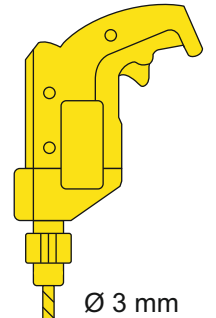

3

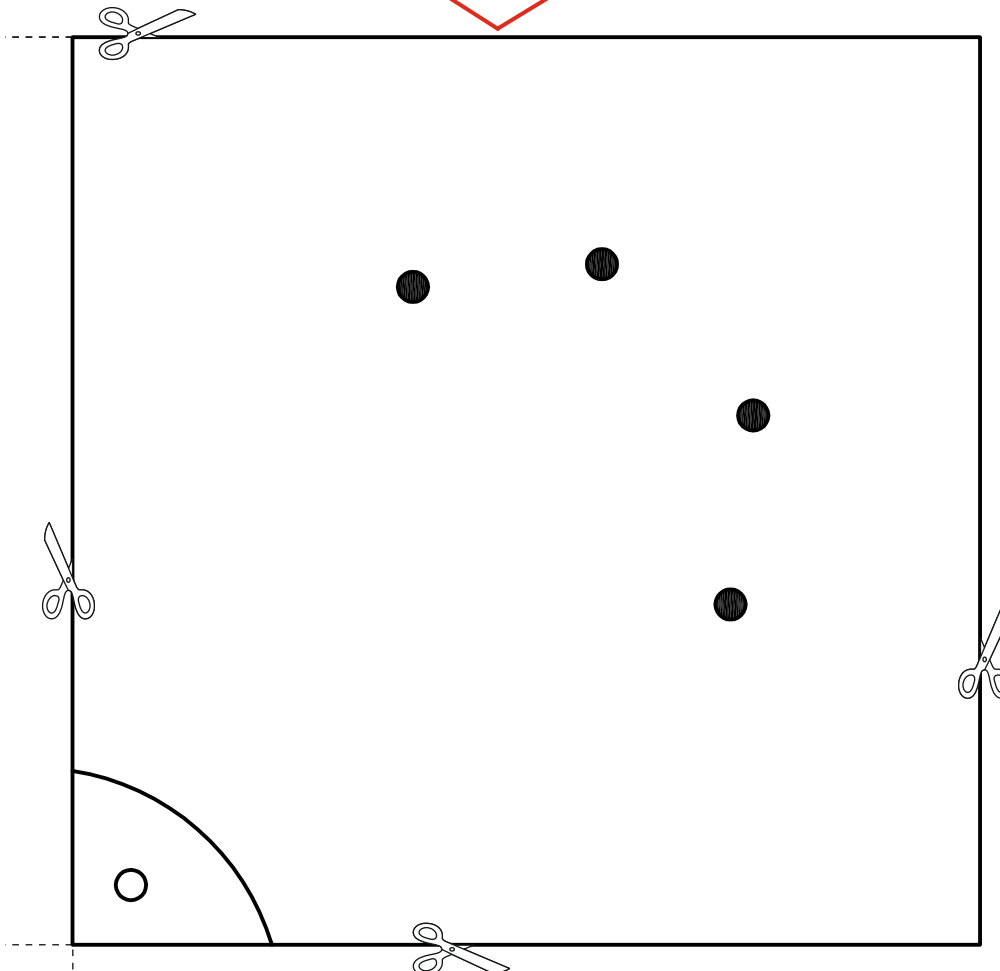
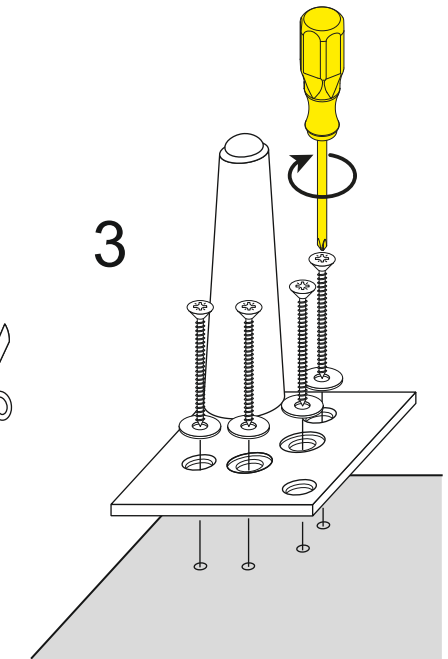

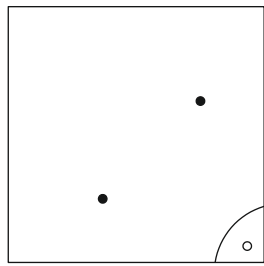
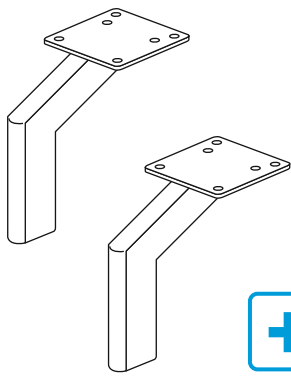

DE Bohrschablone
EN Drilling jig
FR Gabarit de forage
NL Boormal

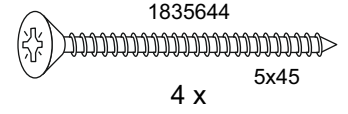
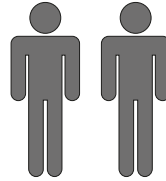
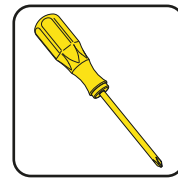
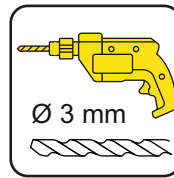

1

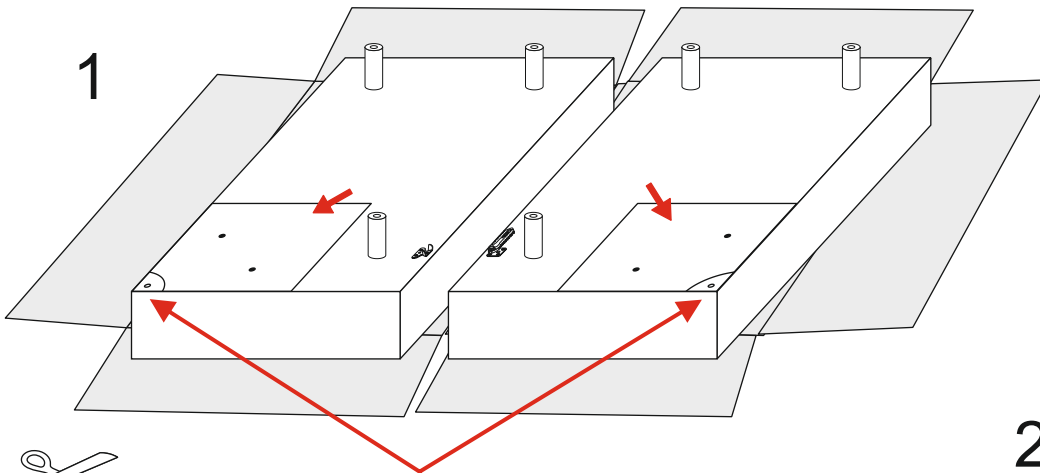

2

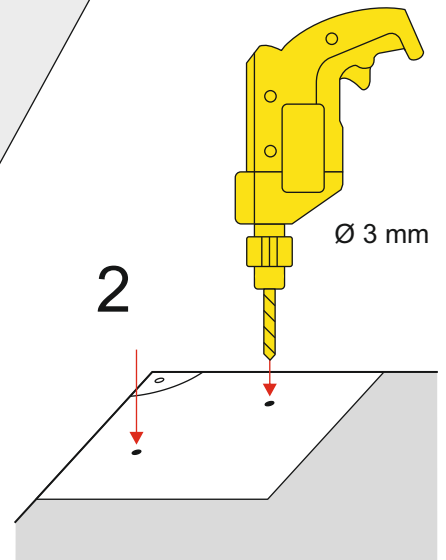

3

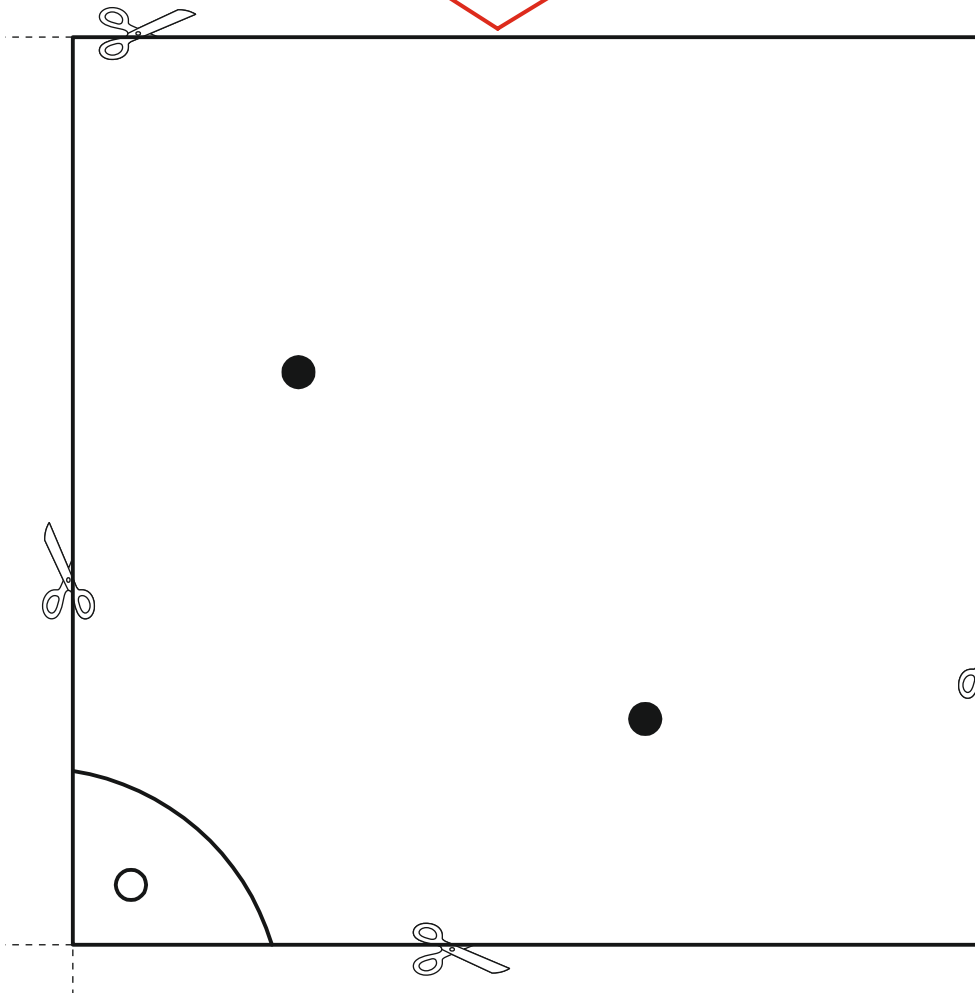
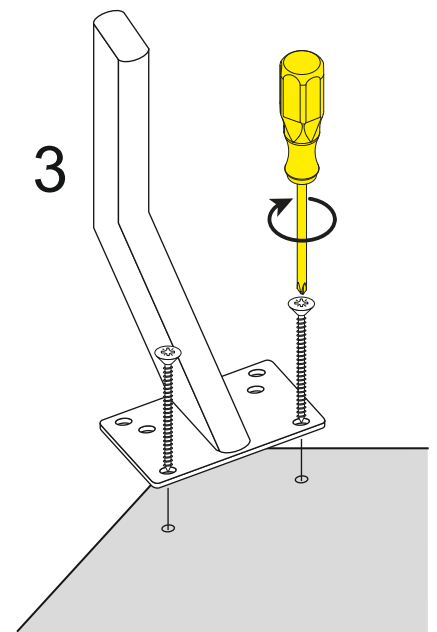

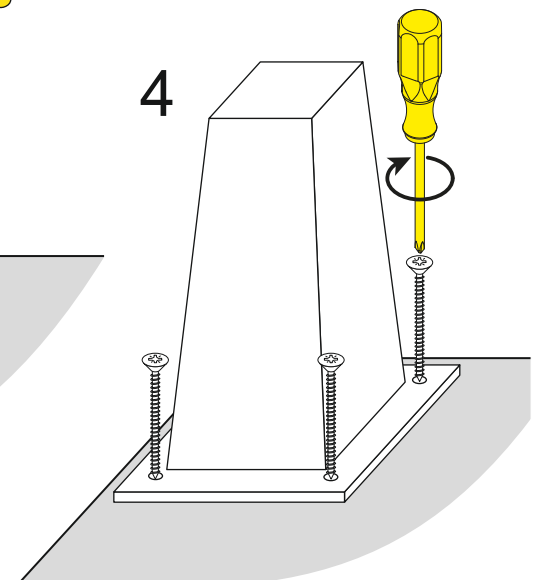
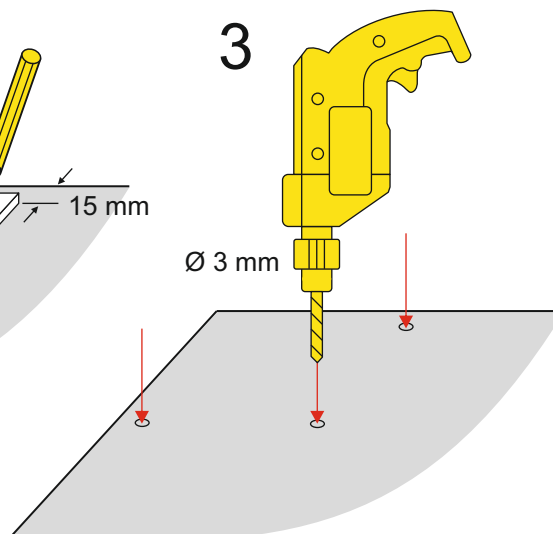
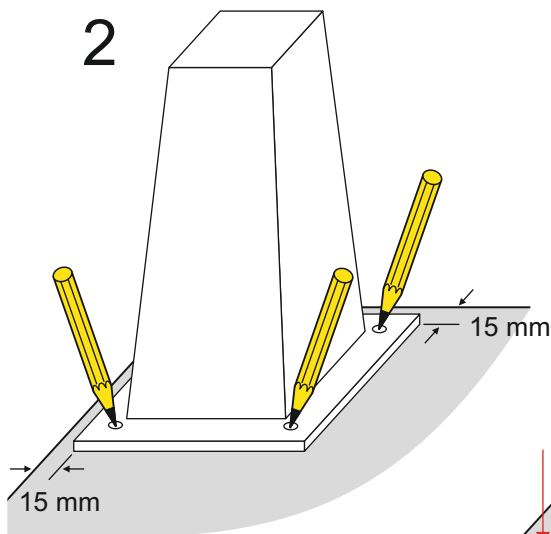
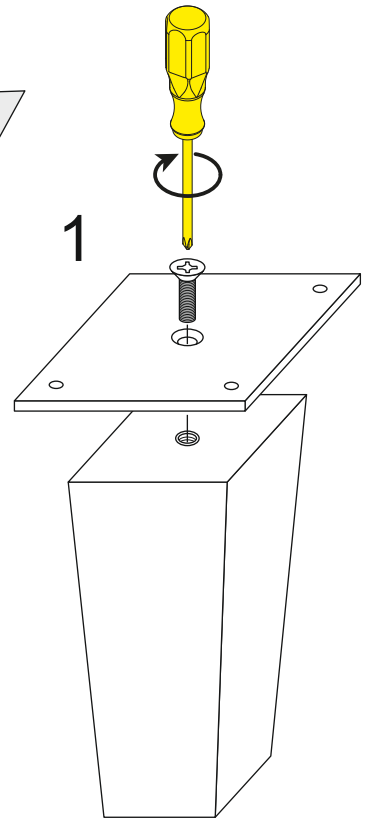
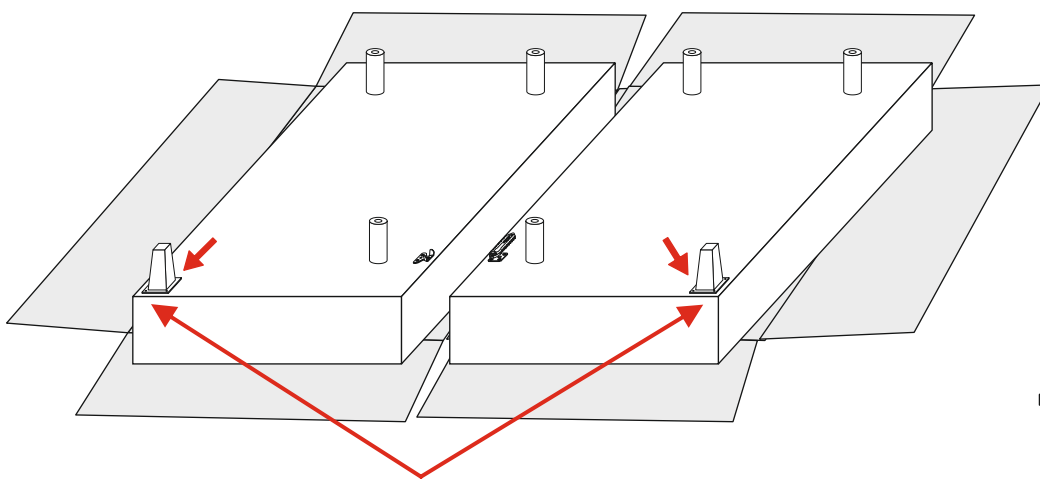
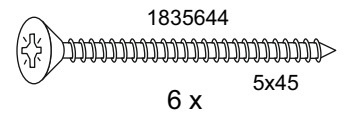
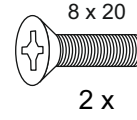
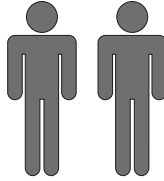
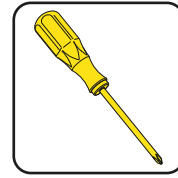
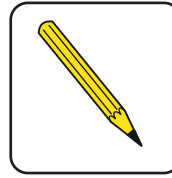
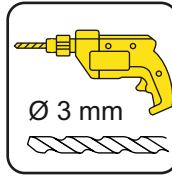
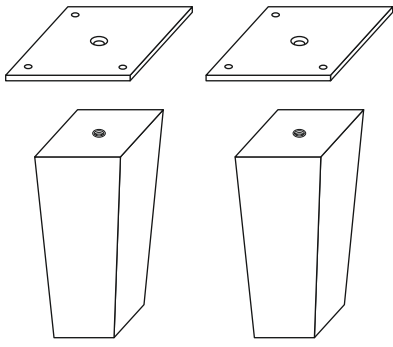

D11

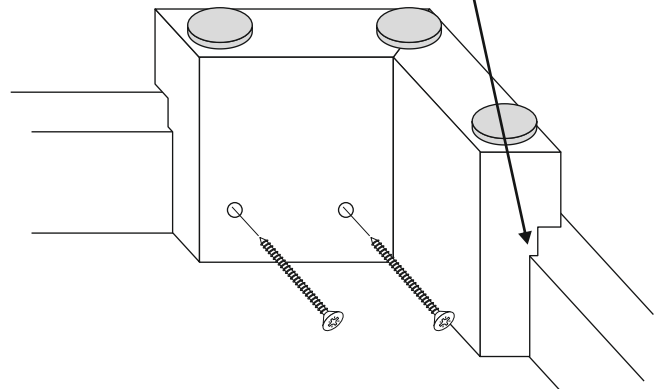
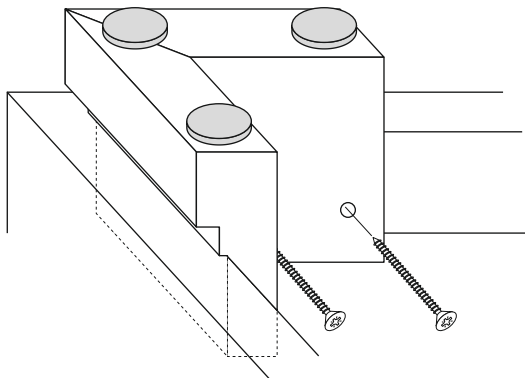
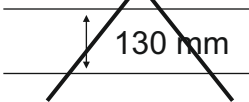
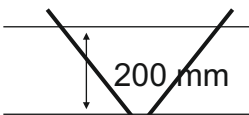
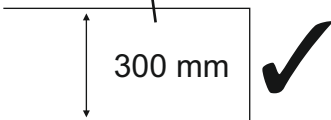
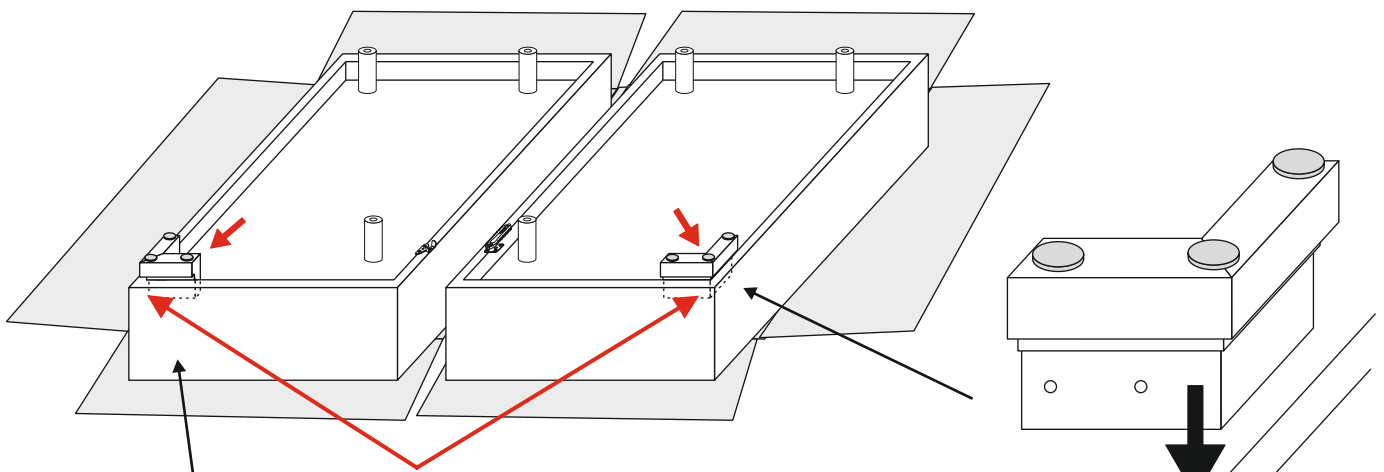
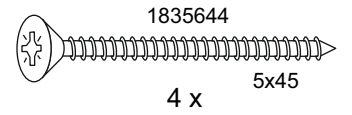
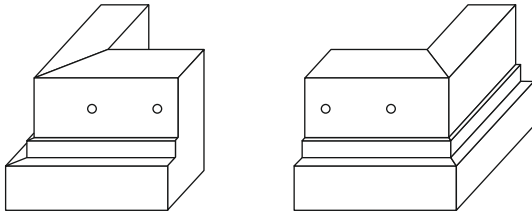
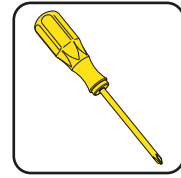
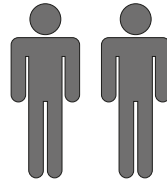

D7

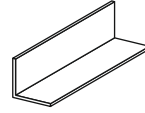
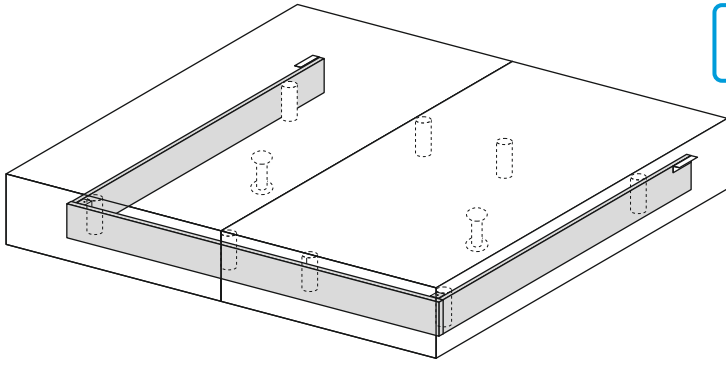

2 x

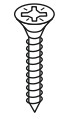

4 x 20

4 x

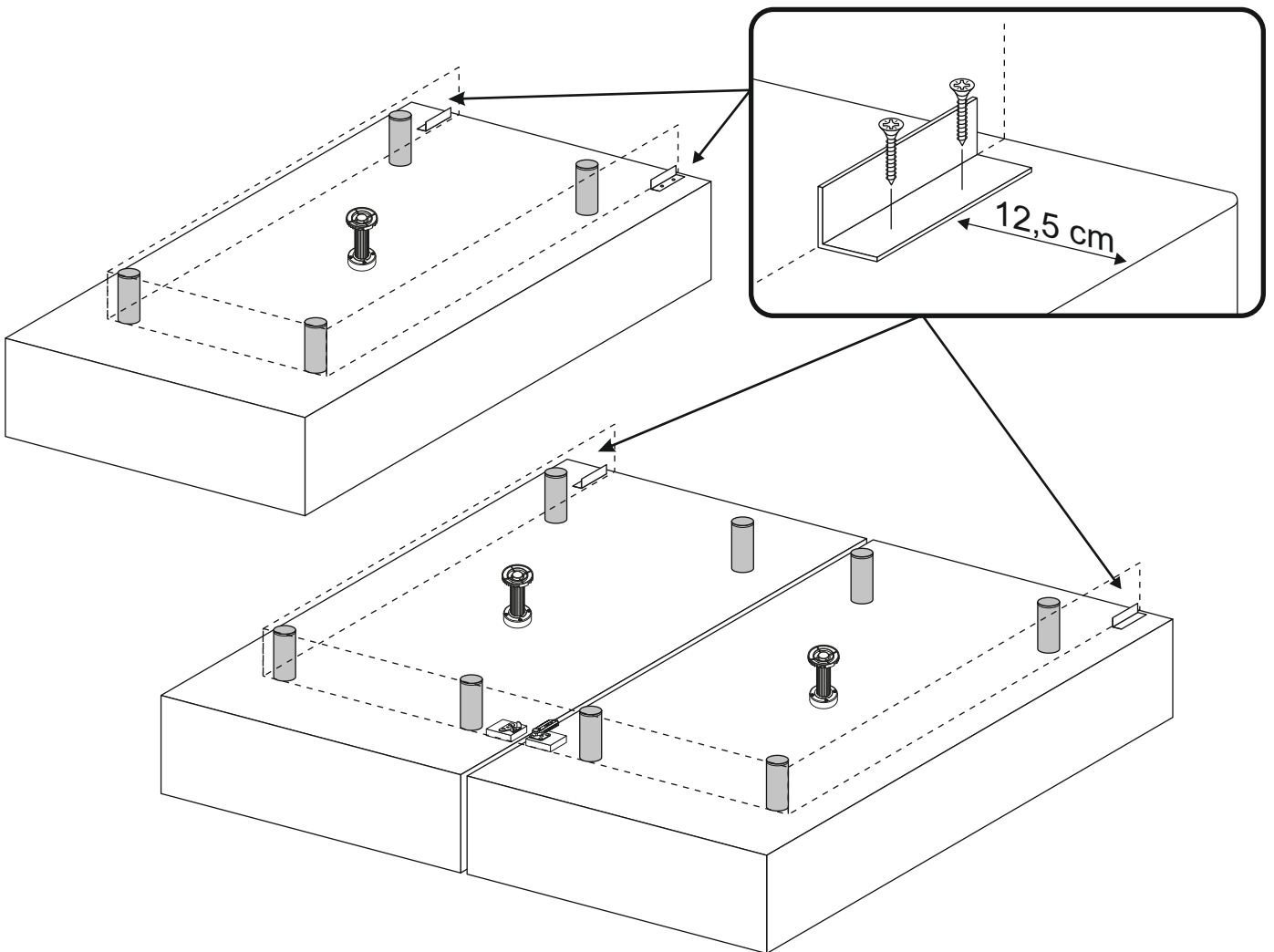
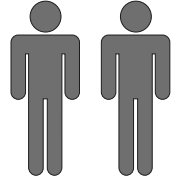

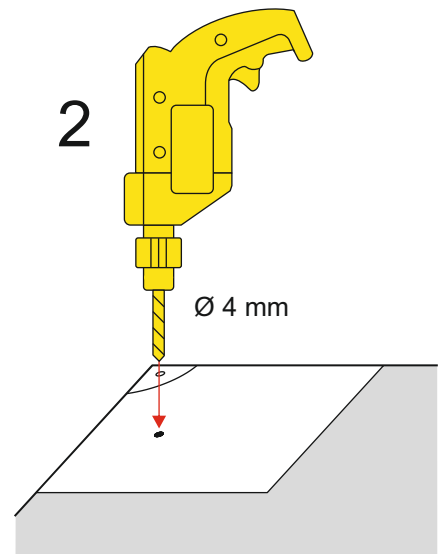
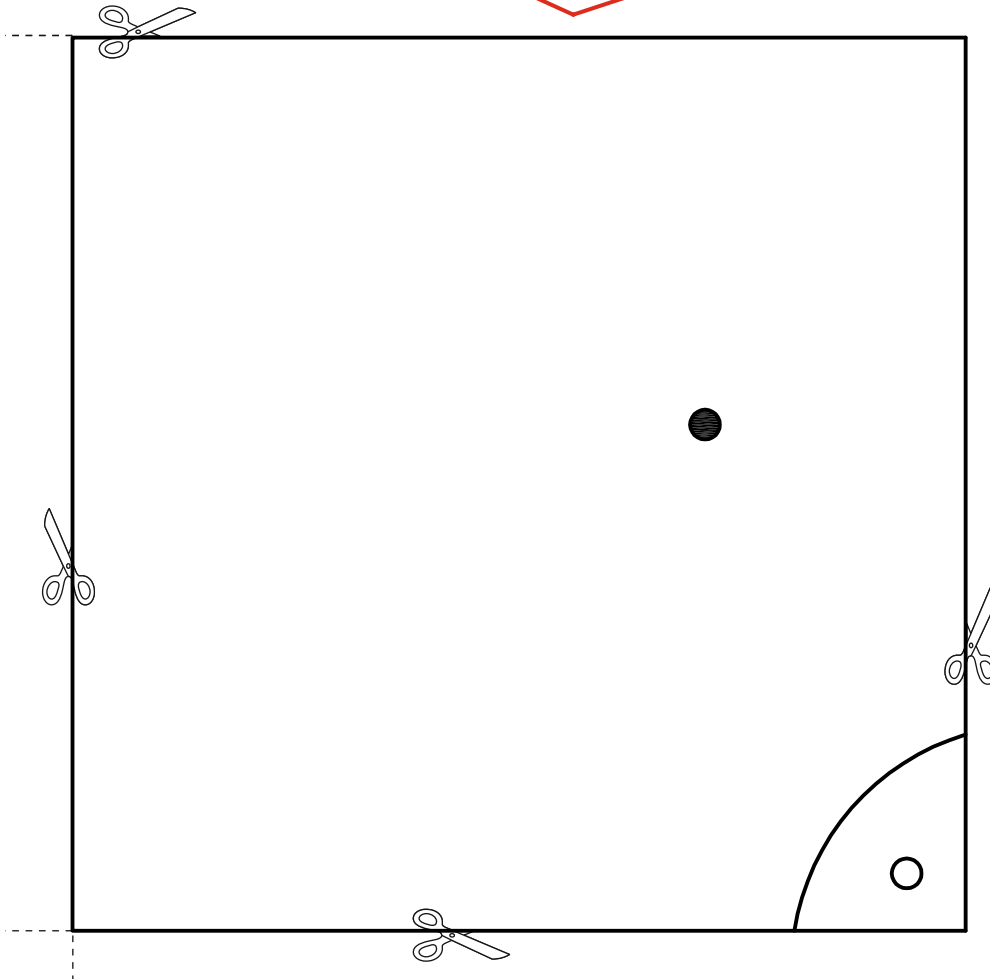
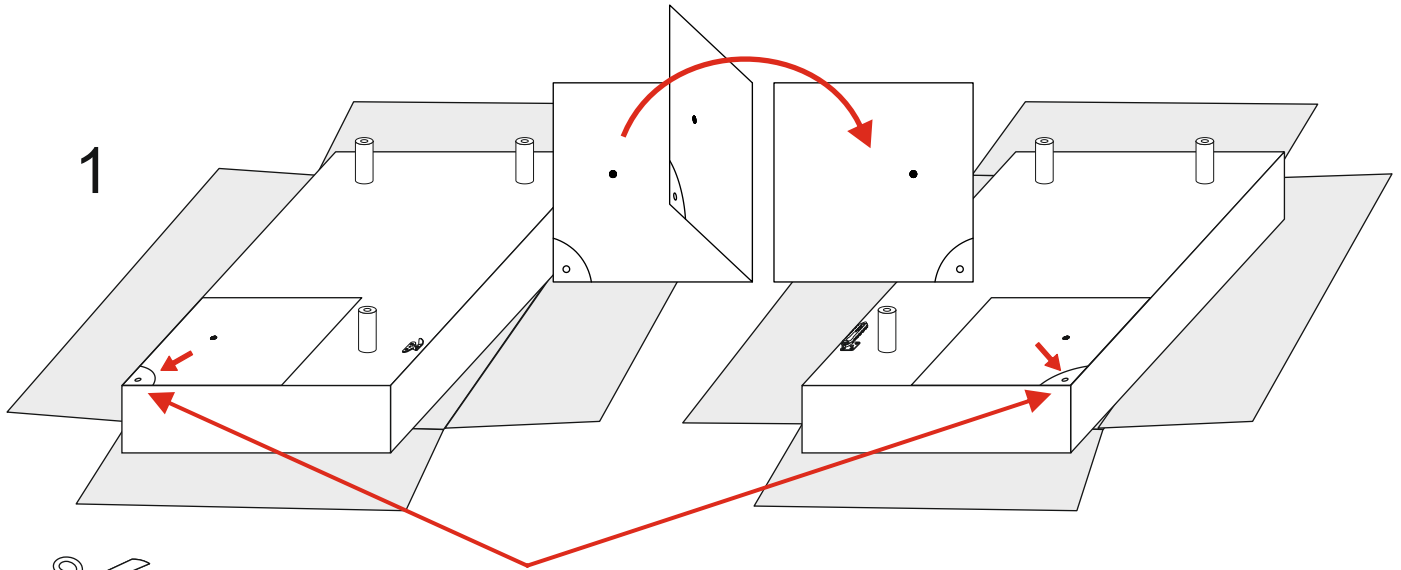
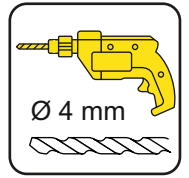
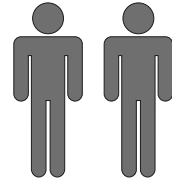
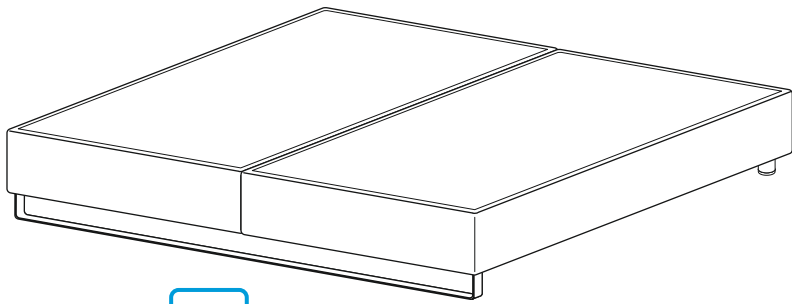

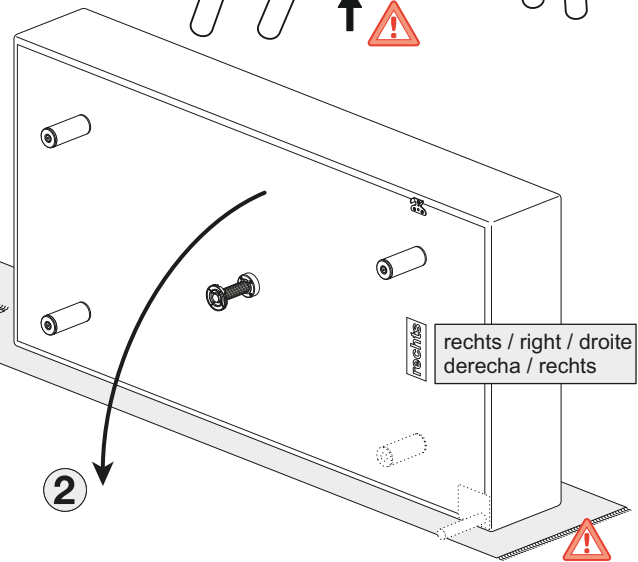
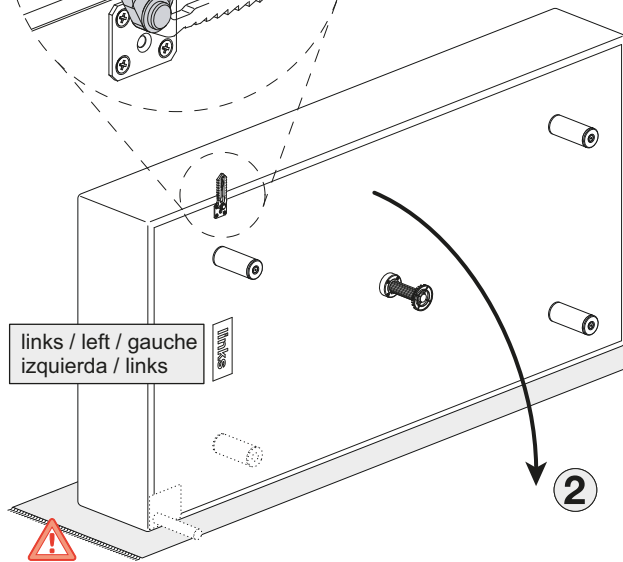
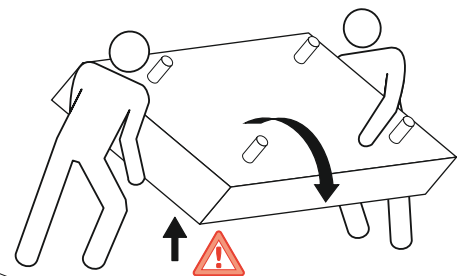
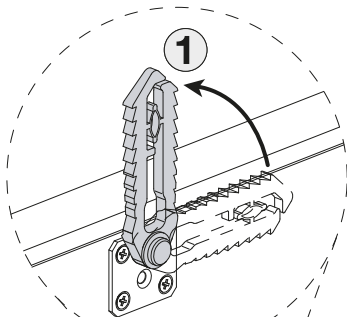
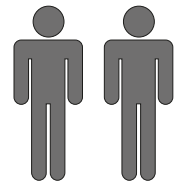
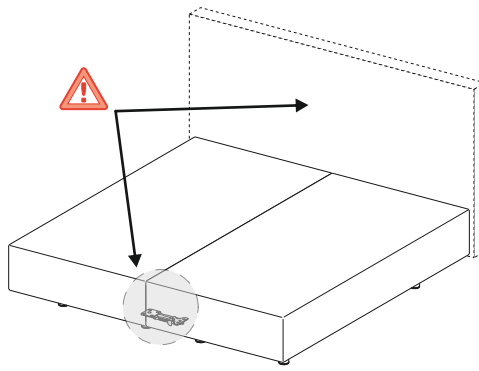
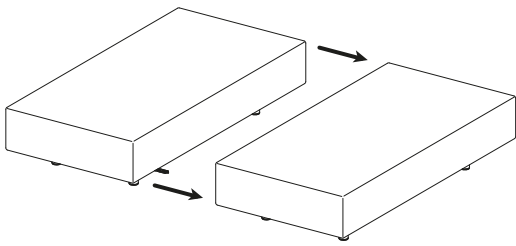

3

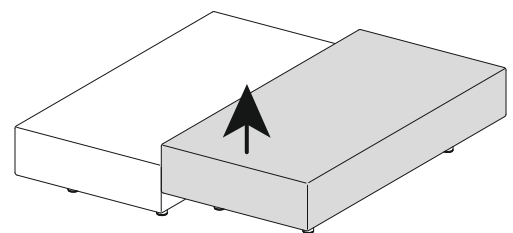
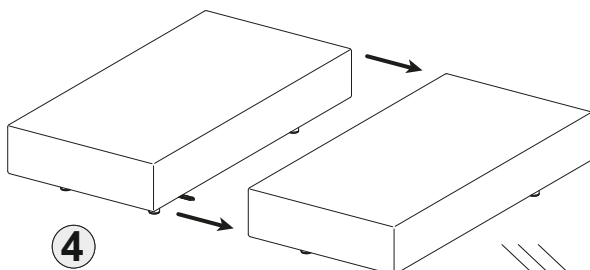
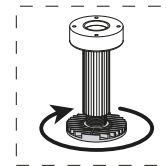
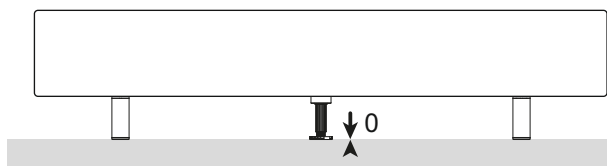

DE Montage
 EN Assembly
 FR Montage
 ES Ensamblaje
 NL Montage

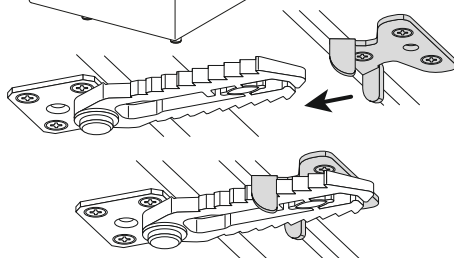

DE Demontage
 EN Disassembly
 FR Demontage
 ES Desmontaje
 NL Demonteren

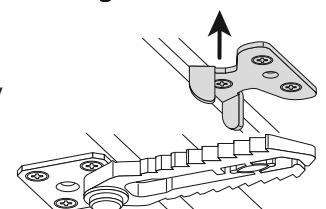

D7

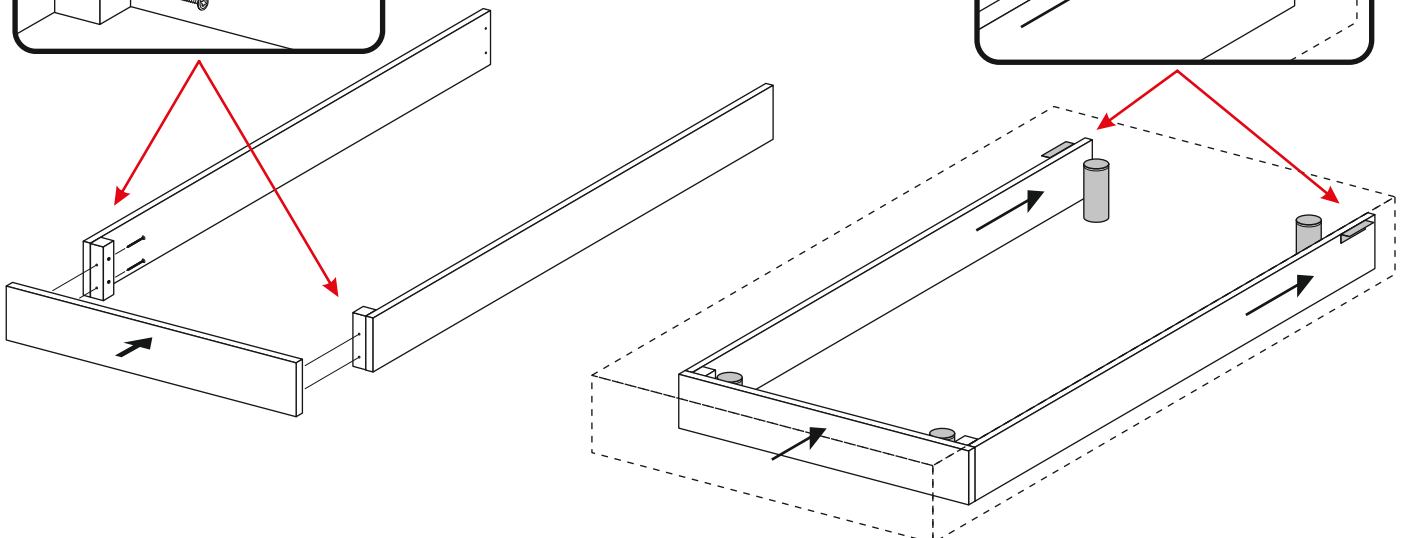
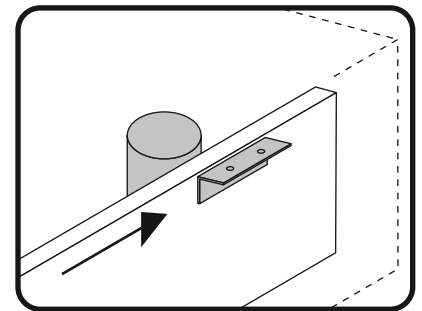
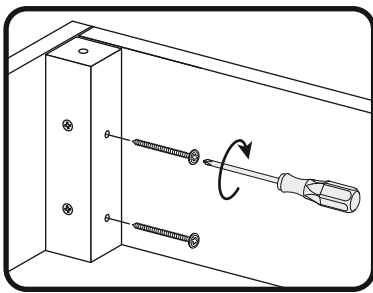
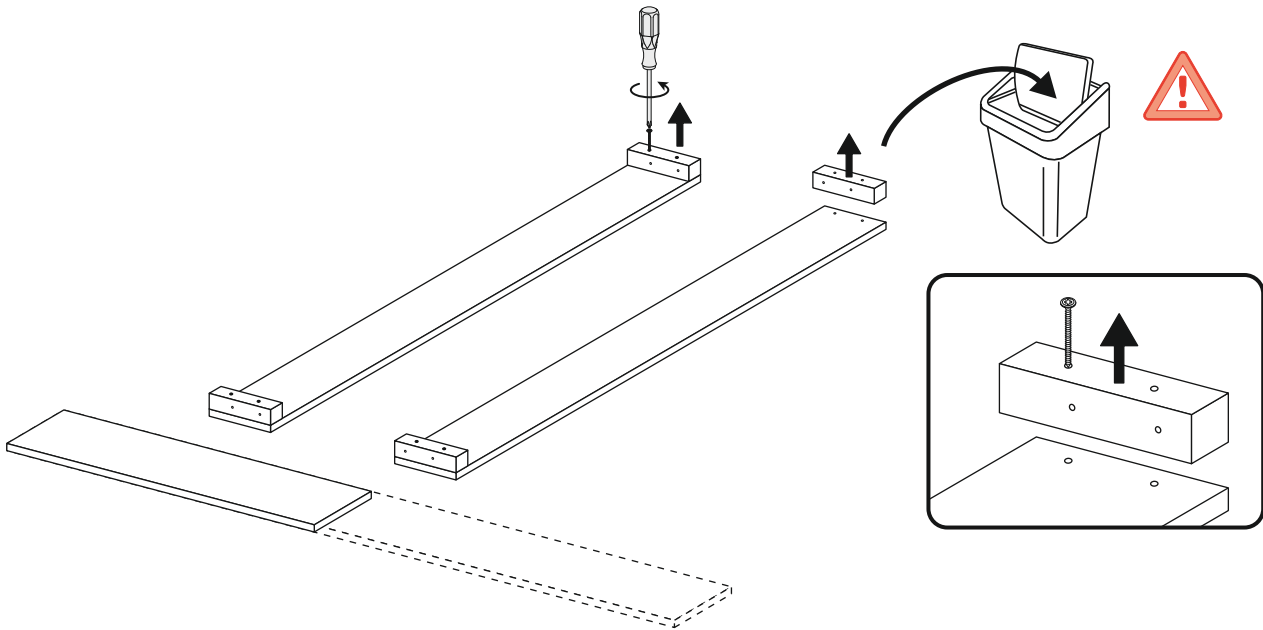
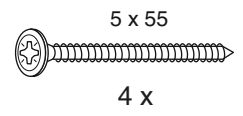
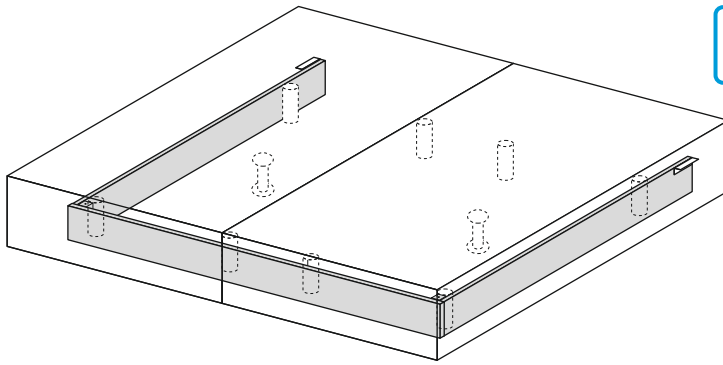
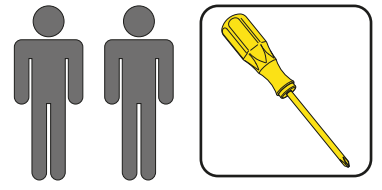

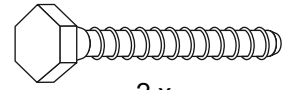
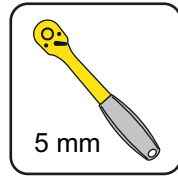
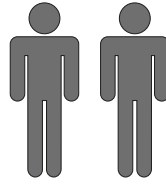
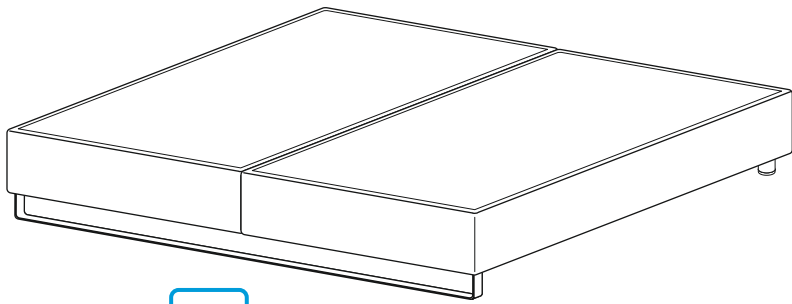

2 x

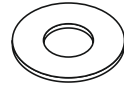

2 x

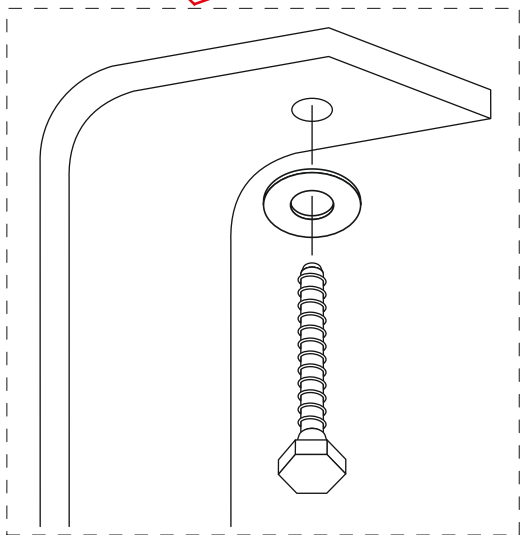
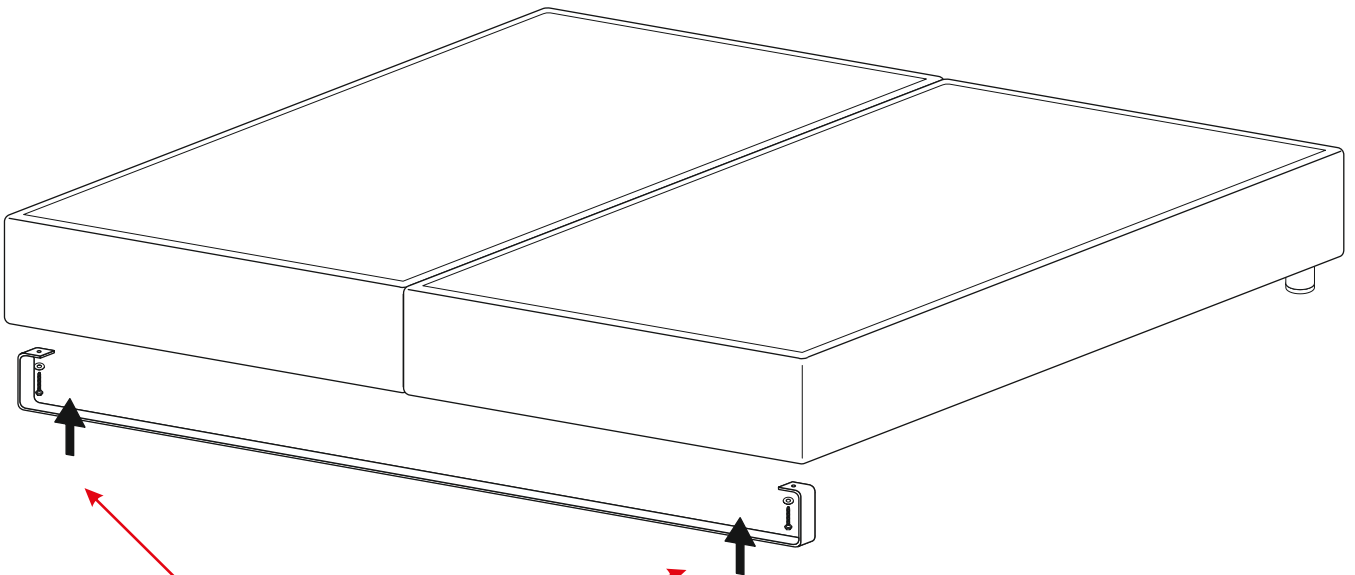

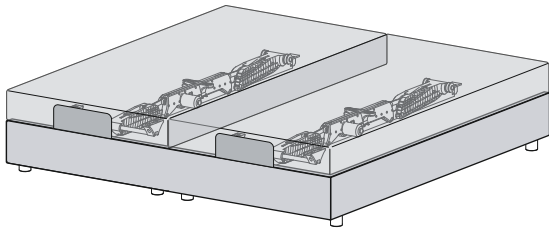

Montage Klett- Volant

Assembly Velcro cover
 Montage Housse velcro
 Montage Klittenband volant

Schritt 1 / Step 1 / Étape 1 / Stap 1:

- DE** An der Fußteilseite des Bettes zunächst alle Nähte gerade ausrichten und fixieren.
- EN** On the footboard side of the bed, first align all seams straight and fix.
- FR** Côté pied de lit redressez d'abord toutes les coutures et fixez.
- NL** Aan het voeteneinde van het bed strijk eerst alle naden recht en fixieren.

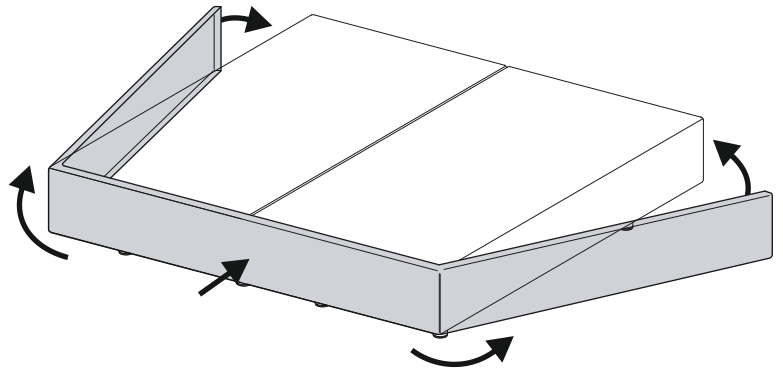

Schritt 2 / Step 2 / Étape 2 / Stap 2:

- DE** Den Klett- Volant zum Kopfteil hin auf Spannung ziehen, Nähte ausrichten und fixieren.
- EN** Pull the Velcro cover towards the headboard for tension, align seams and fix.
- FR** Tirez le Housse velcro vers la tête de lit pour la tension, alignez les coutures et fixez.
- NL** Trek de Klittenband volant naar het hoofdeinde toe voor spanning, naden uitlijnen en fixeren

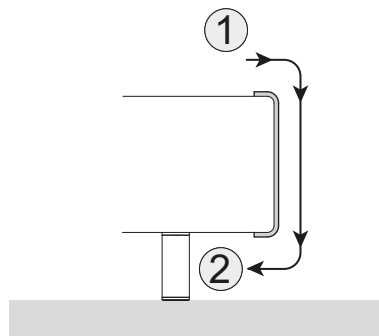

Schritt 3 / Step 3 / Étape 3 / Stap 3:

- DE** Erst **nach** der Montage des Klett- Volants das Kopfteil in die vormontierten Beschläge einsetzen.
- EN** Only **after** mounting the Velcro cover, insert the headboard in the pre-assembled fittings.
- FR** Seulement **après** avoir monté le Housse velcro, insérez la tête de lit dans les ferrures pré-assemblées.
- NL** Pas **na** montage van de Klittenband volant het hoofdbord in de voorgemonteerde fittingen.

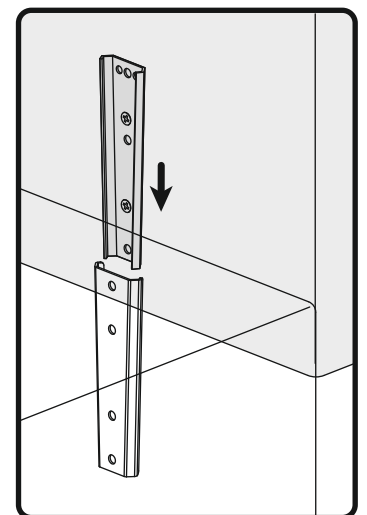
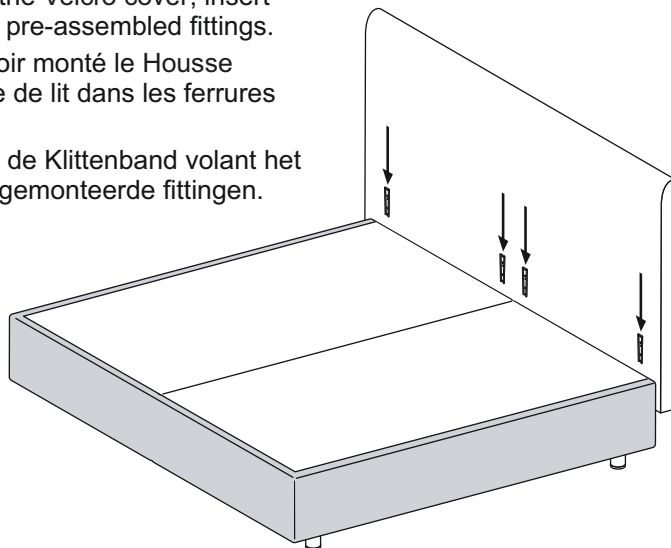

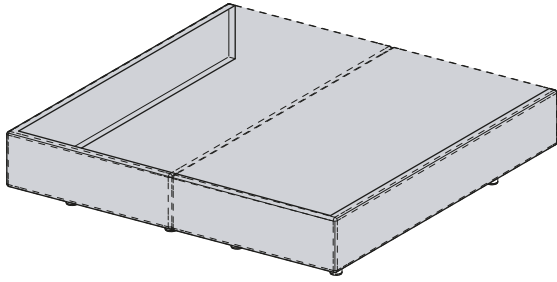

Montage Klett- Volant

Assembly Velcro cover
 Montage Housse velcro
 Montage Klittenband volant

Schritt 1 / Step 1 / Étape 1 / Stap 1:

- DE** An der Fußteilstseite des Bettes zunächst alle Nähte gerade ausrichten und fixieren.
- EN** On the footboard side of the bed, first align all seams straight and fix.
- FR** Côté pied de lit redressez d'abord toutes les coutures et fixez.
- NL** Aan het voeteneinde van het bed strijk eerst alle naden recht en fixieren.

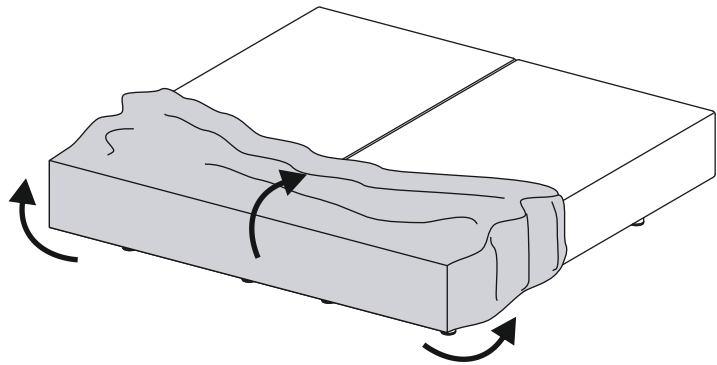

Schritt 2 / Step 2 / Étape 2 / Stap 2:

- DE** Den Klett- Volant zum Kopfteil hin auf Spannung ziehen, Nähte ausrichten und fixieren.
- EN** Pull the Velcro cover towards the headboard for tension, align seams and fix.
- FR** Tirez le Housse velcro vers la tête de lit pour la tension, alignez les coutures et fixez.
- NL** Trek de Klittenband volant naar het hoofdeinde toe voor spanning, naden uitlijnen en fixeren

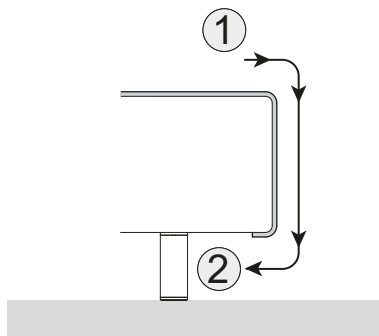

Schritt 3 / Step 3 / Étape 3 / Stap 3:

- DE** Erst **nach** der Montage des Klett- Volants das Kopfteil in die vormontierten Beschläge einsetzen.
- EN** Only **after** mounting the Velcro cover, insert the headboard in the pre-assembled fittings.
- FR** Seulement **après** avoir monté le Housse velcro, insérez la tête de lit dans les ferrures pré-assemblées.
- NL** Pas **na** montage van de Klittenband volant het hoofdbord in de voorgemonteerde fittingen.

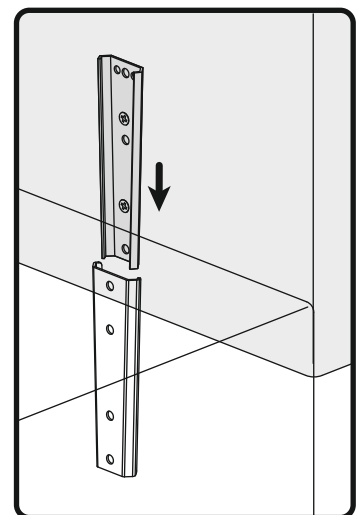
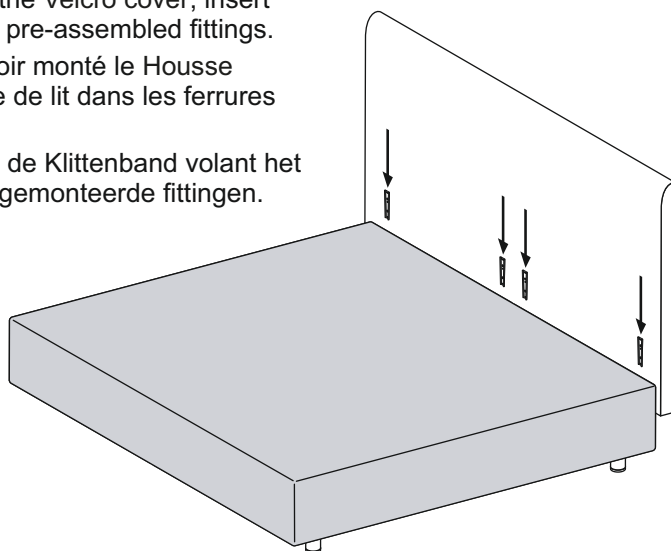

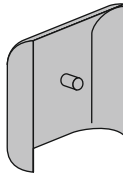

1 x

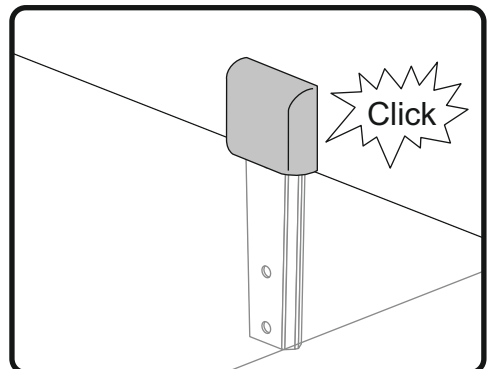
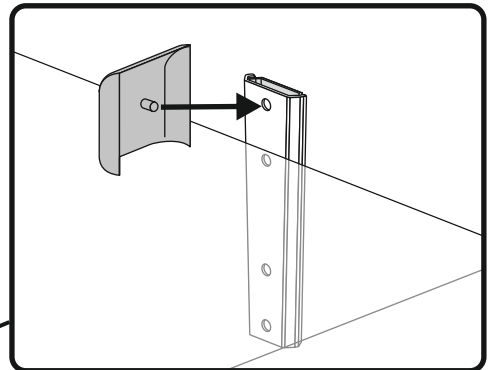
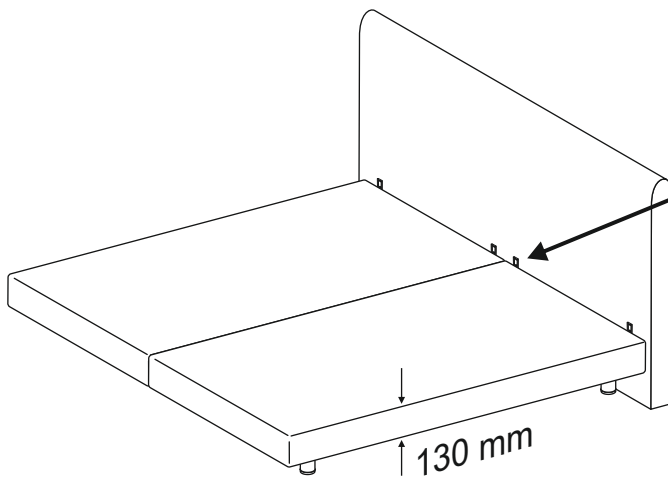
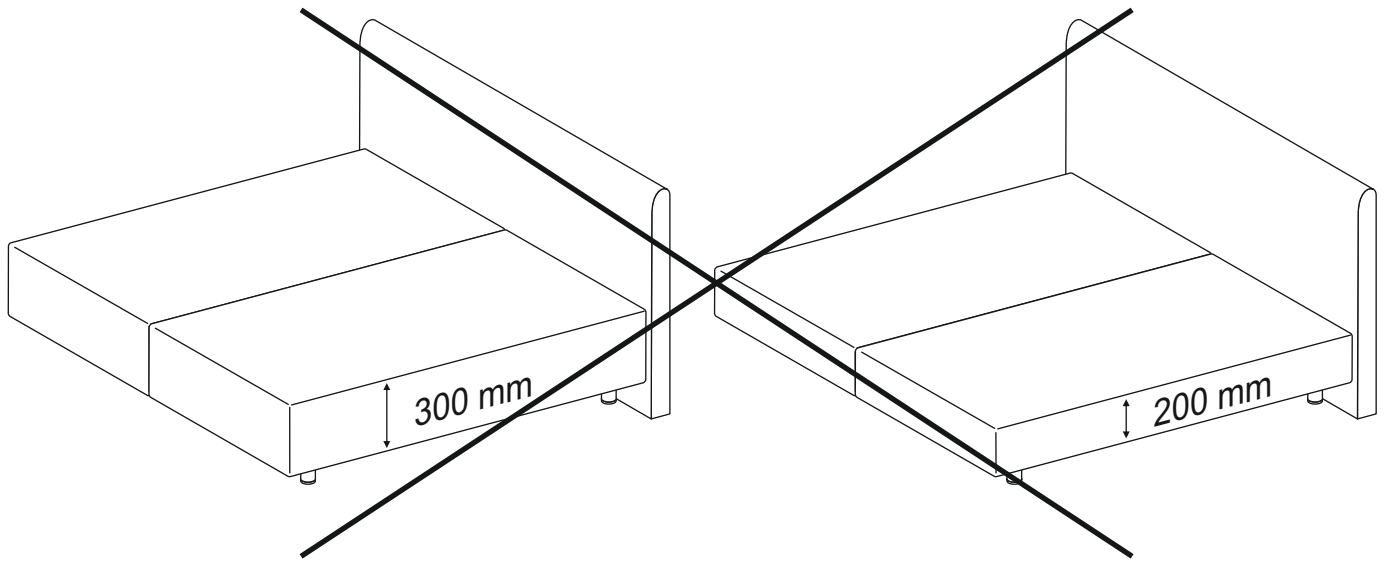

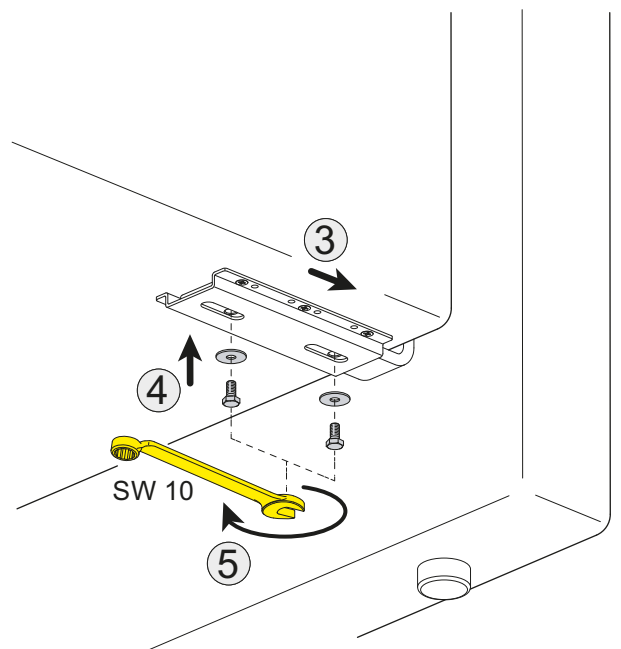
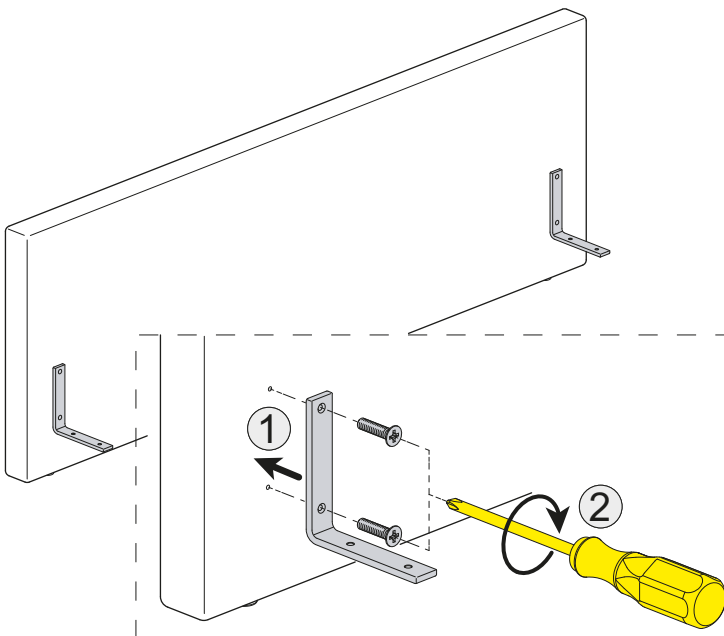
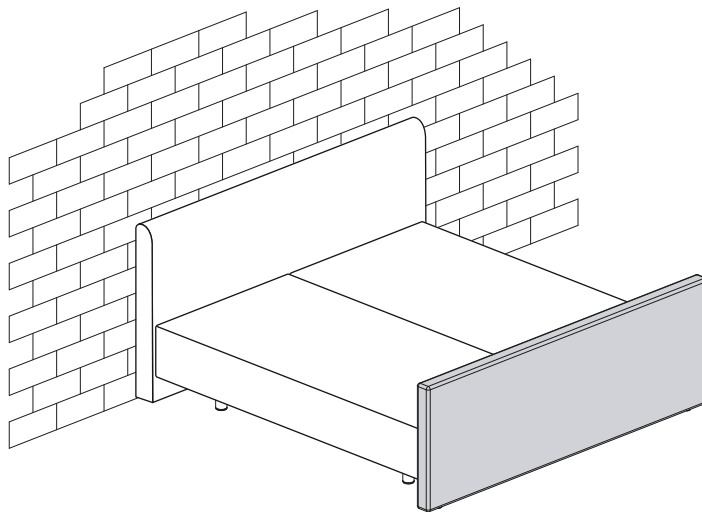
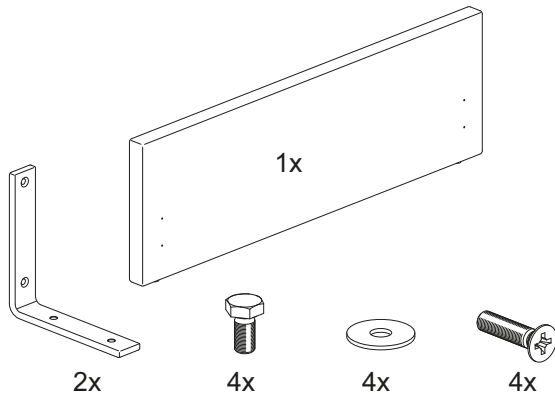
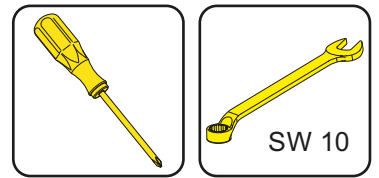

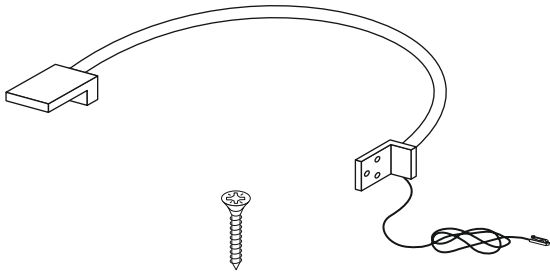

3 x

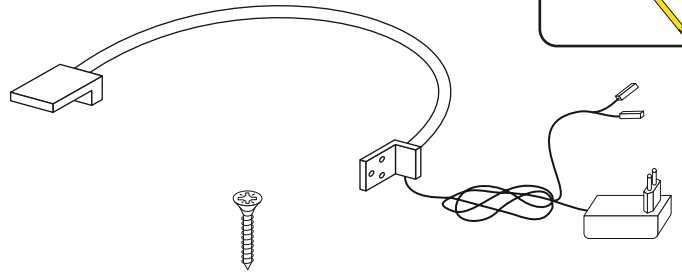

3 x

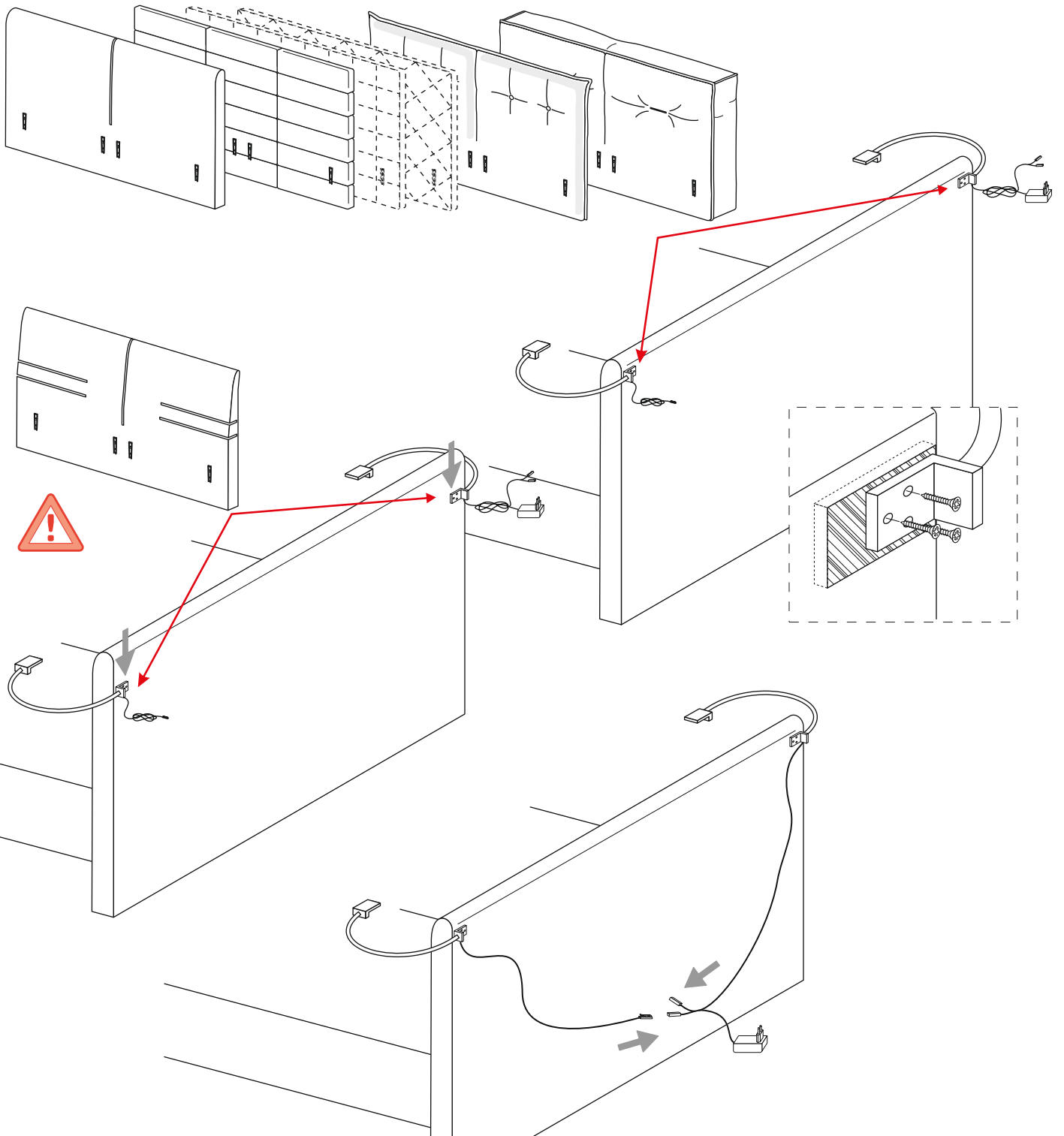

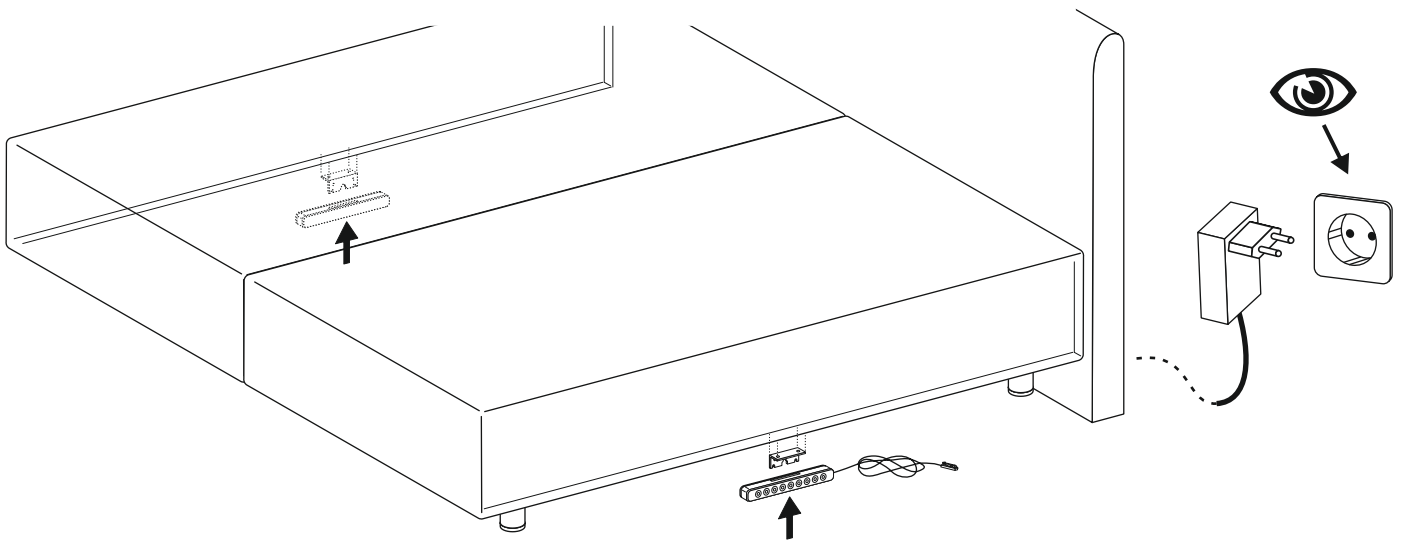
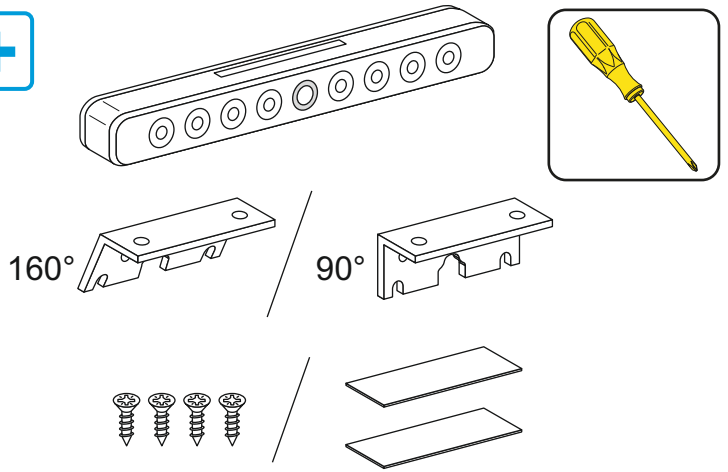
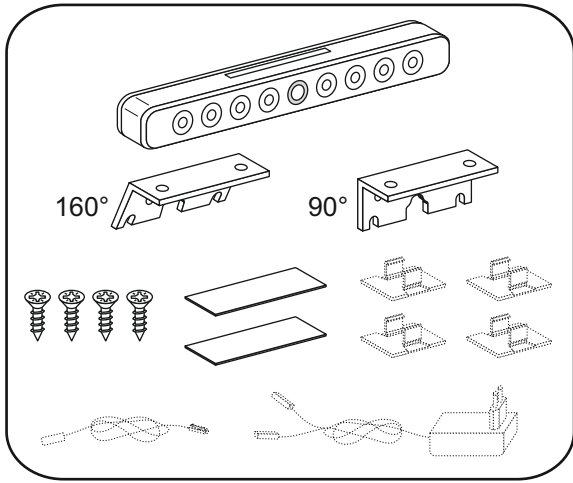

Option 1

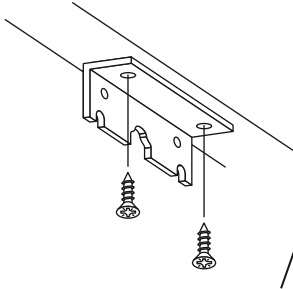

Option 2

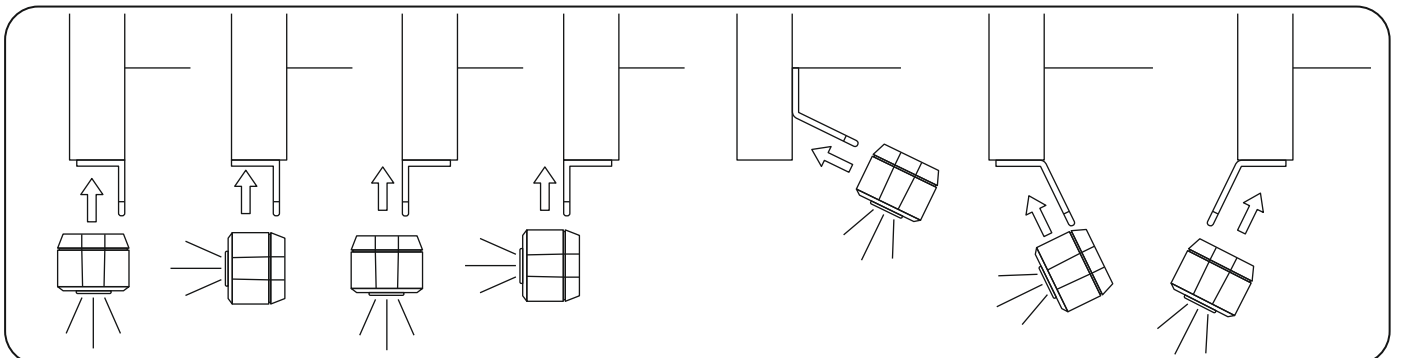
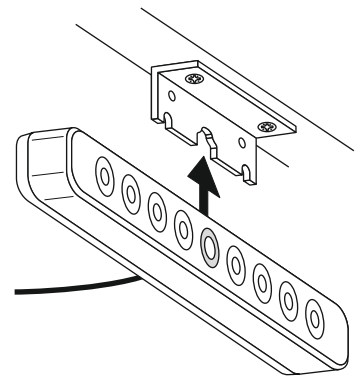
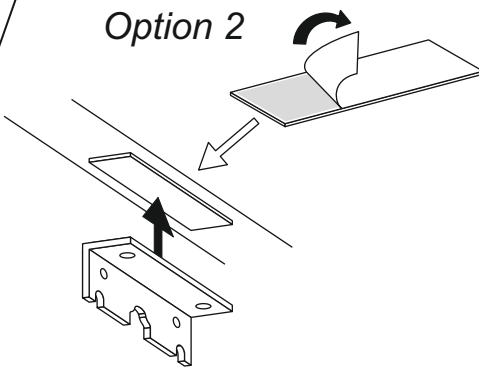

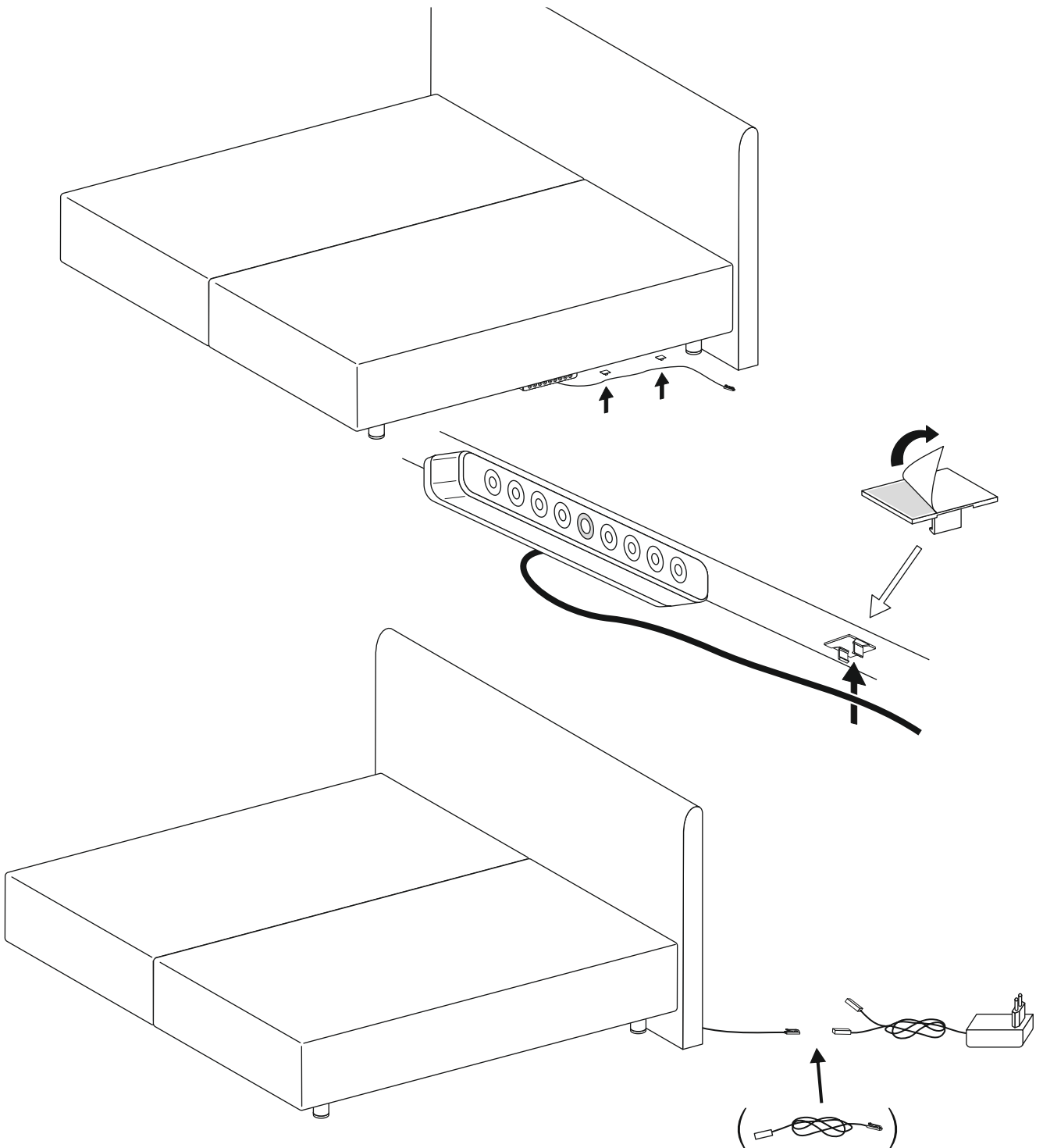
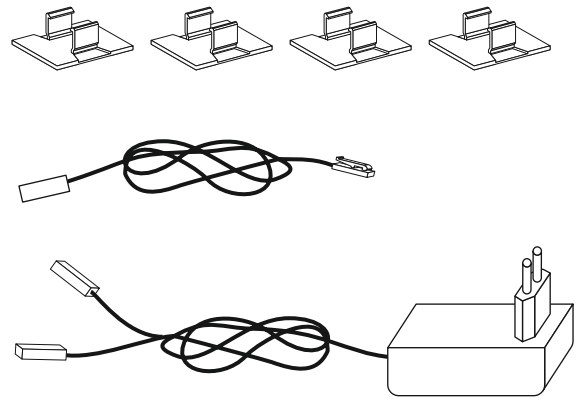
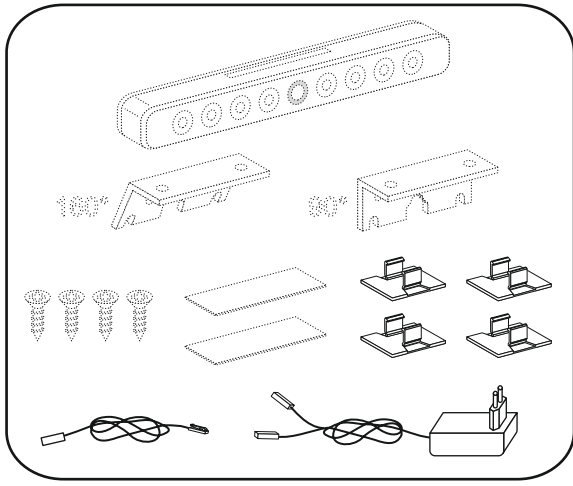

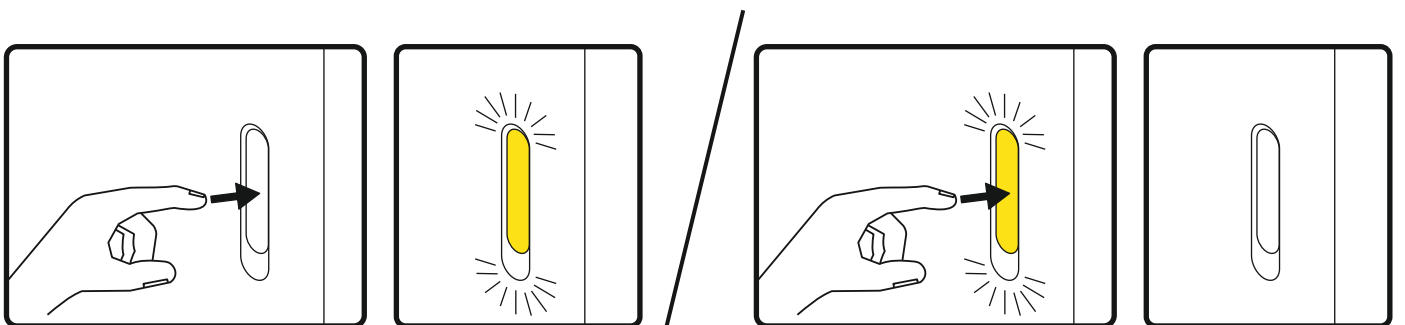
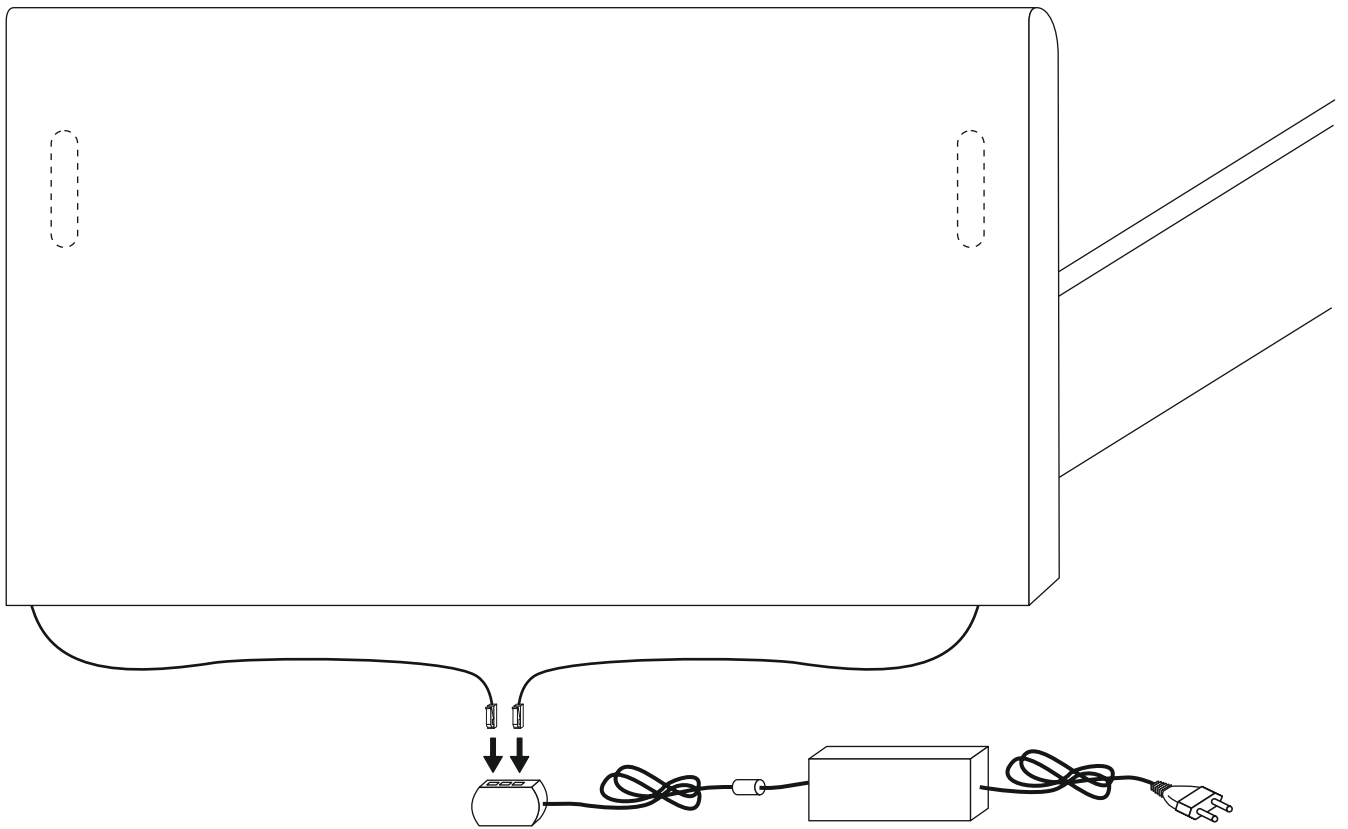
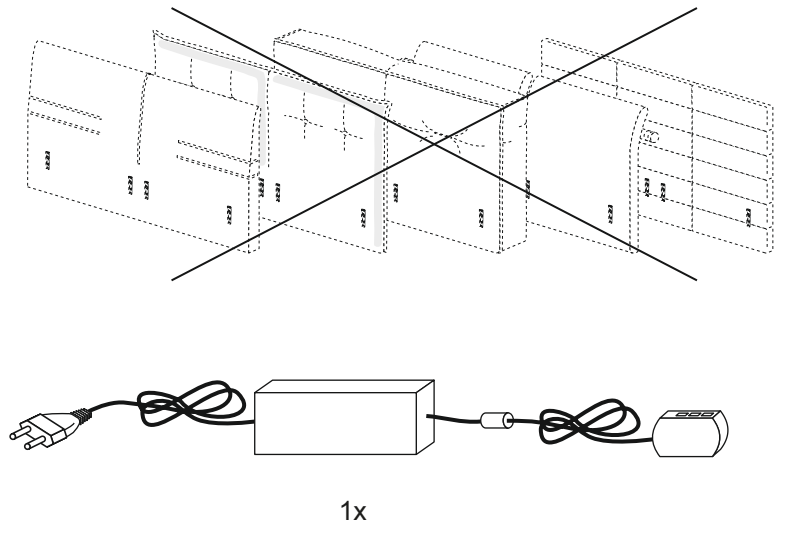
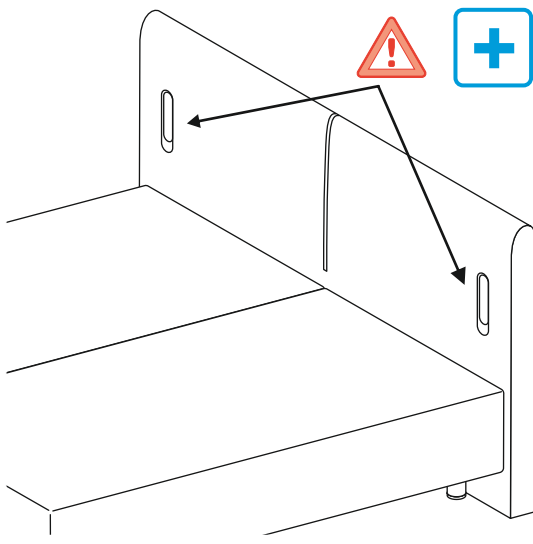

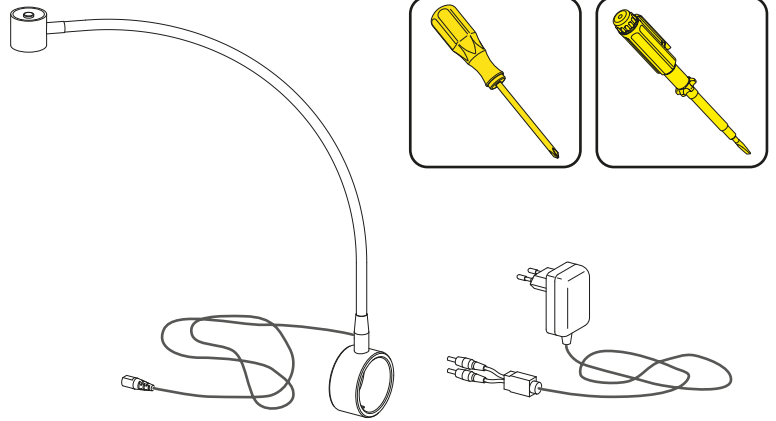
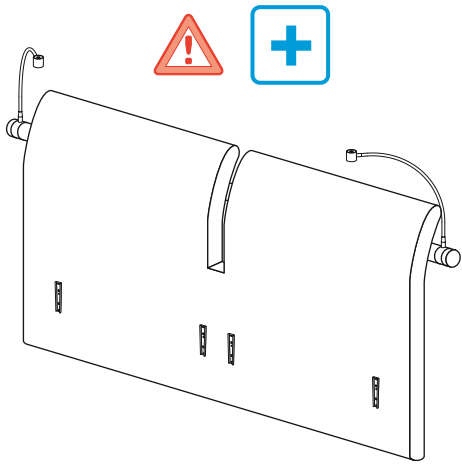

1x

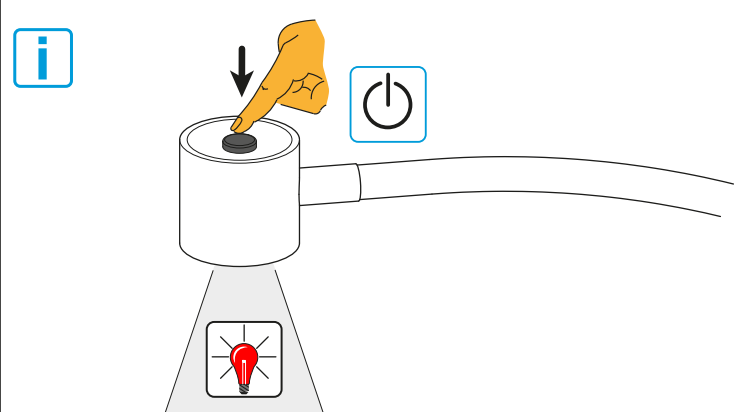
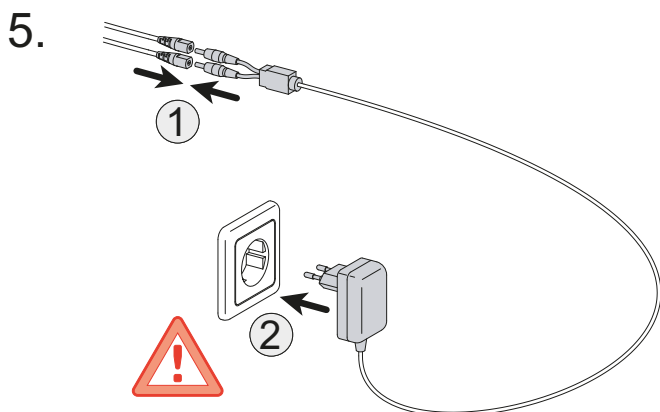
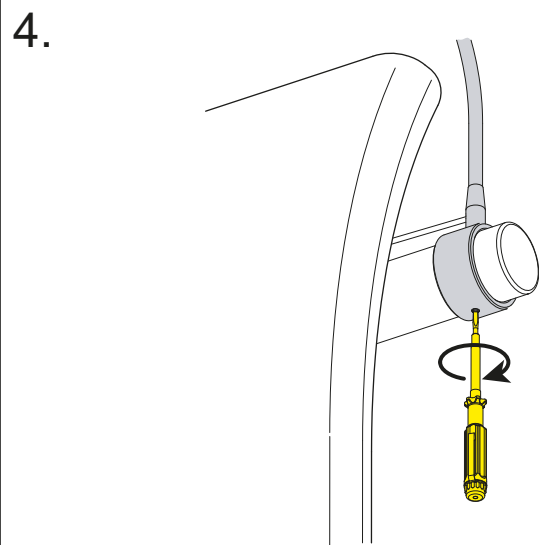
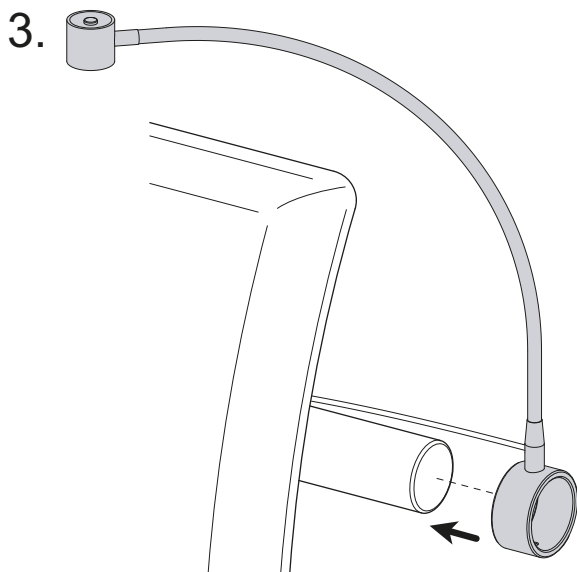
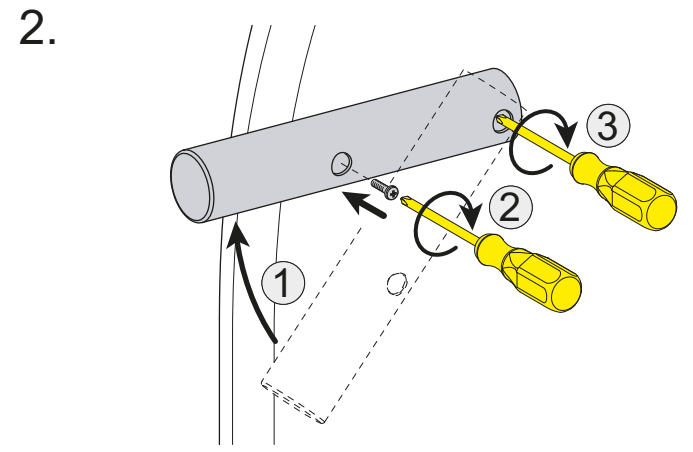
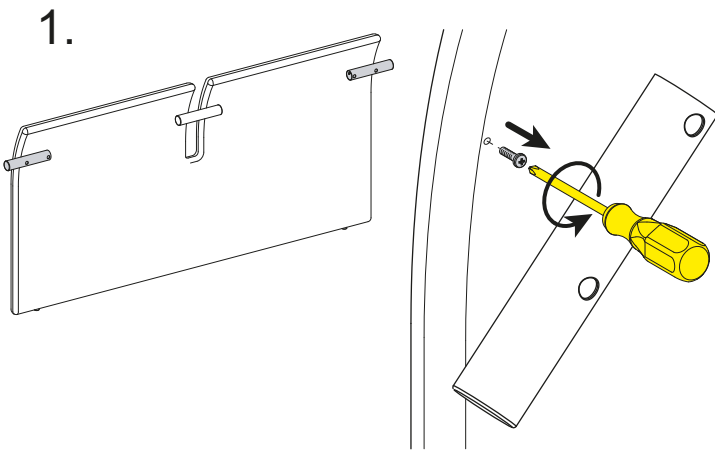

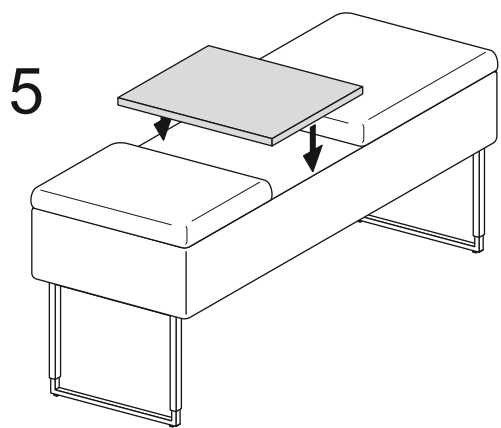
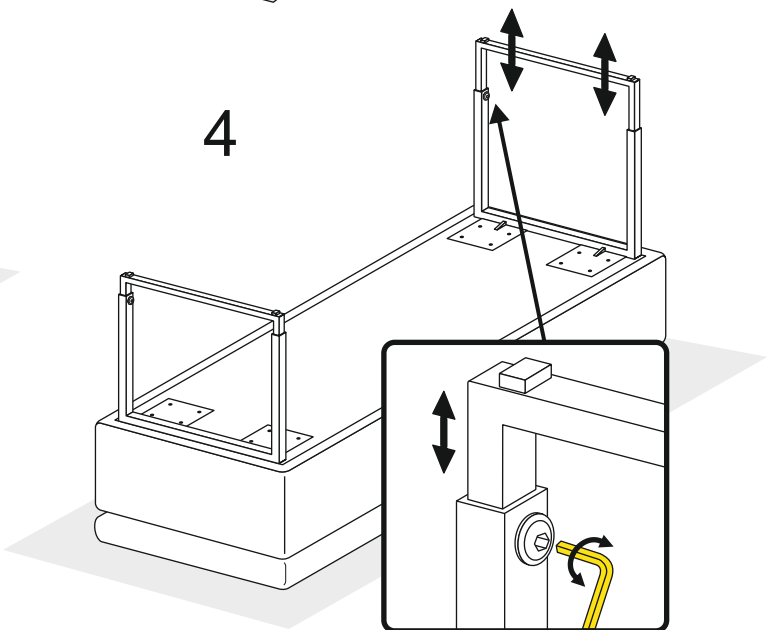
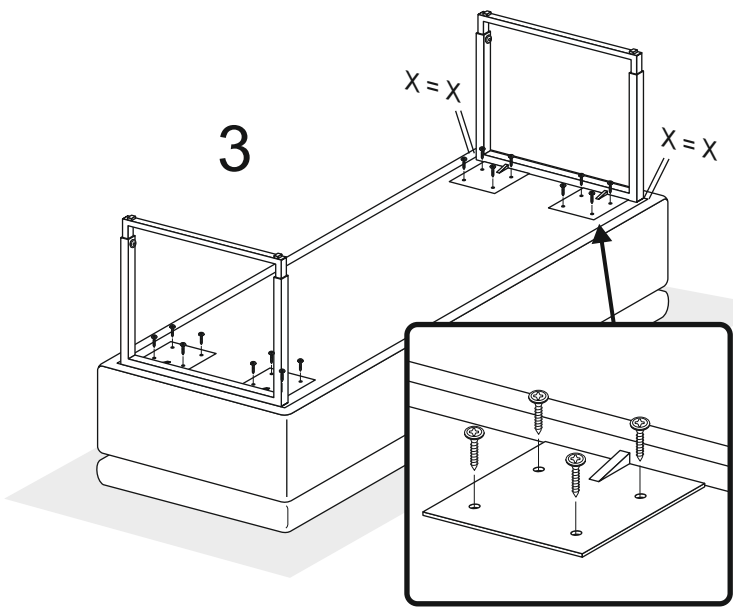
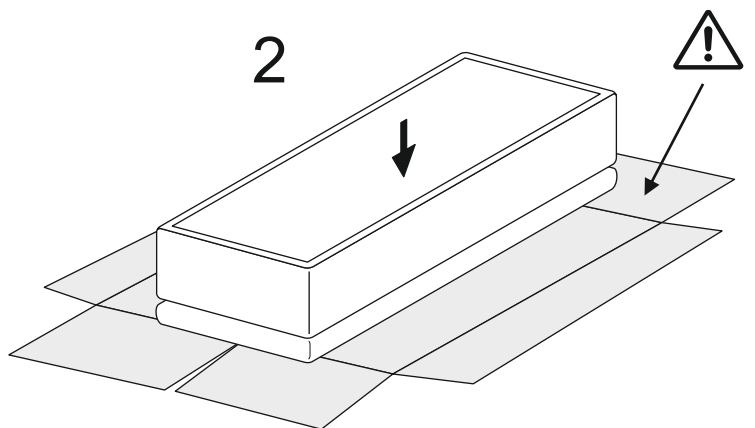
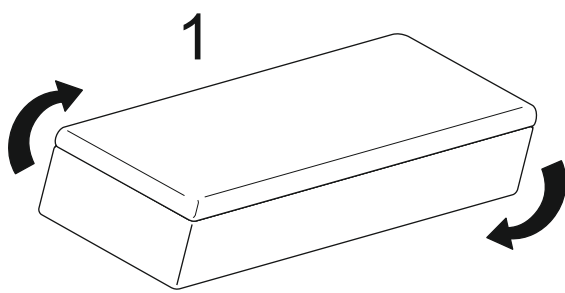
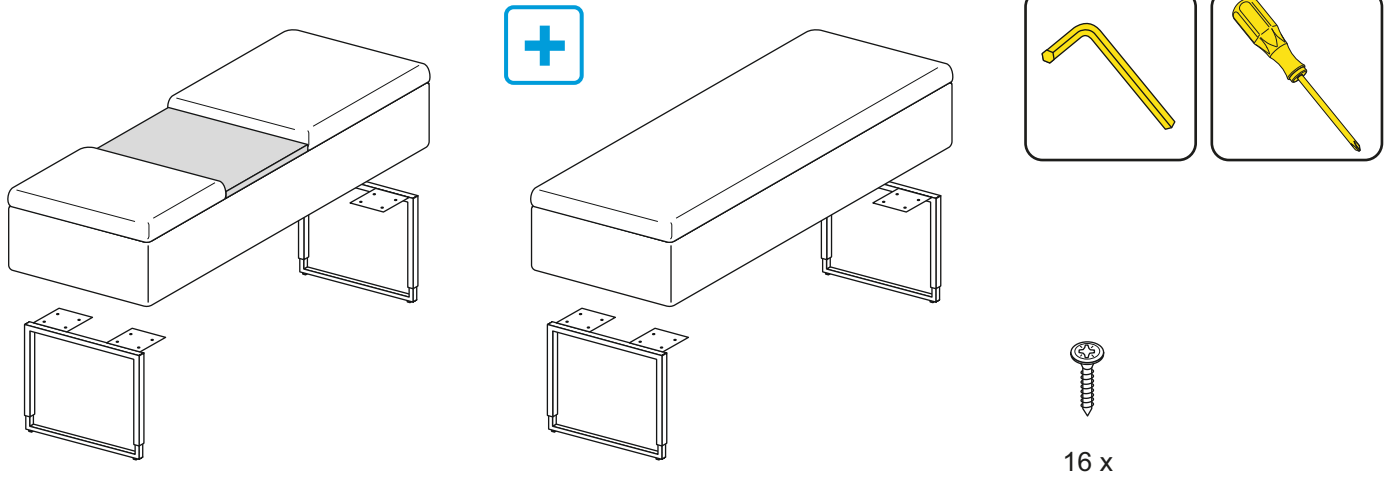

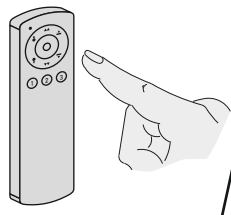
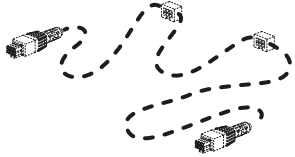
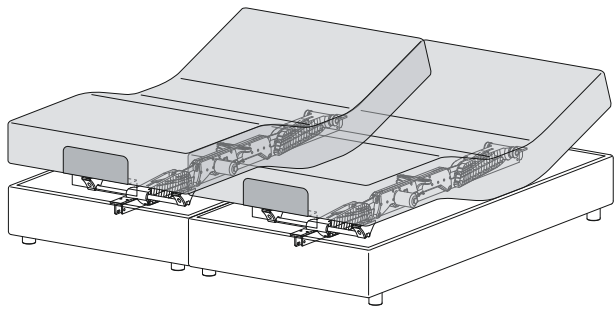

Option

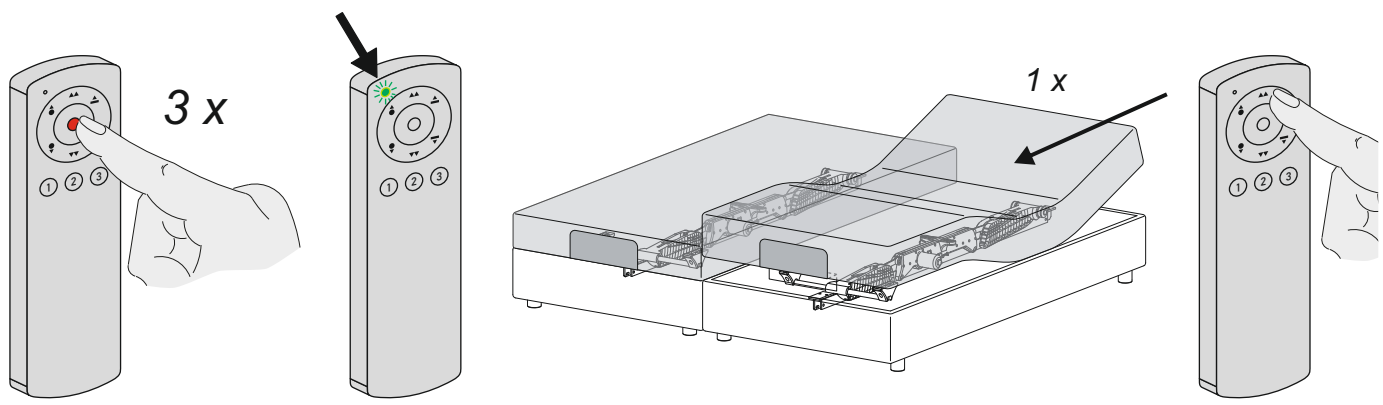
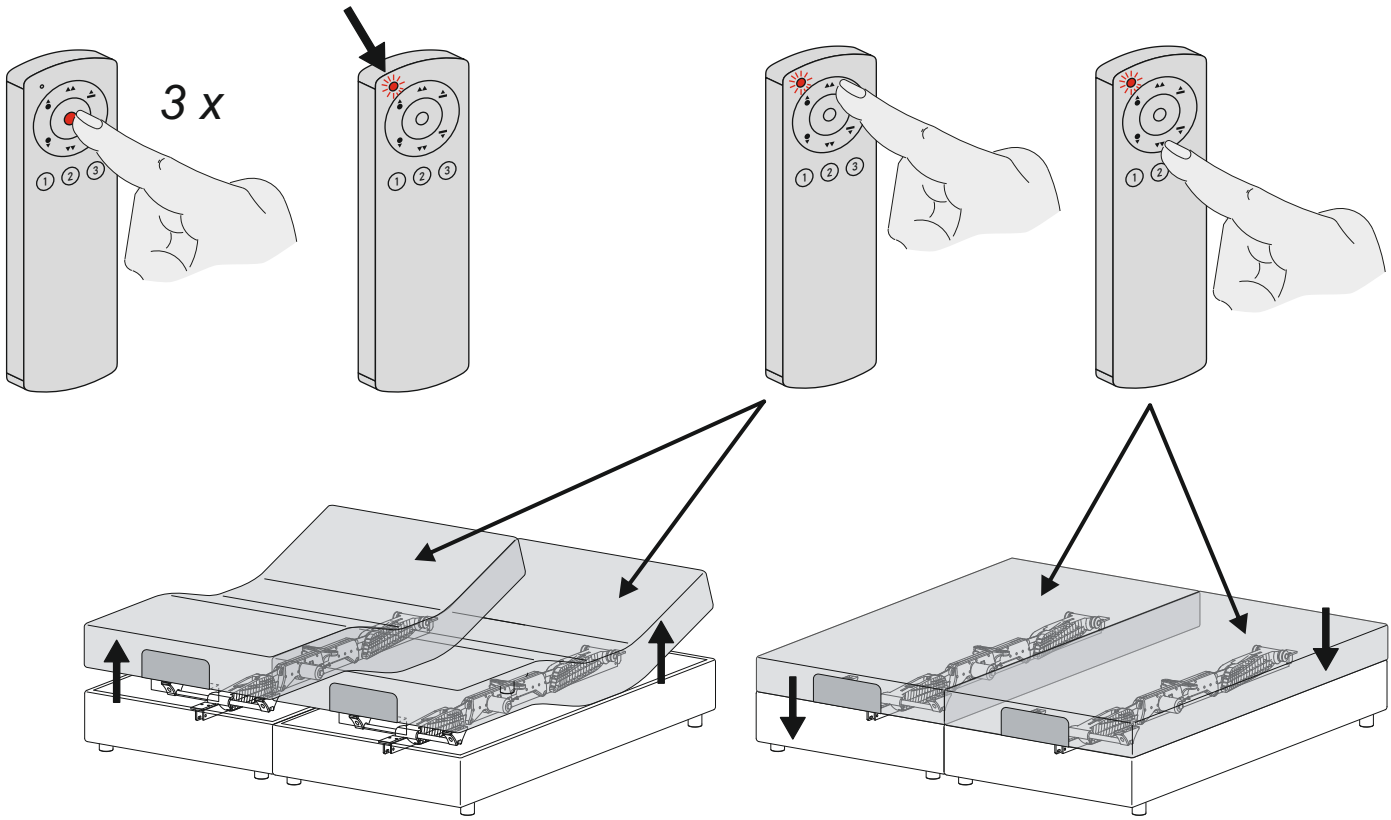
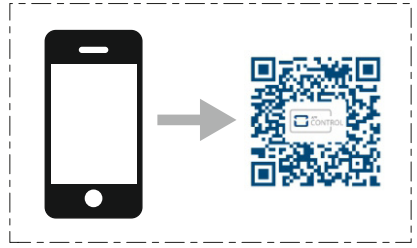

- DE** Die Verbindung beider Antriebssysteme ist eine Schaltung (parallel) und es kann beim Verfahren in Abhängigkeit der jeweiligen Belastung auf einer oder anderen Bettseite zum Versatz während des Verfahrens kommen. Das ist kein Reklamationsgrund. Sollte ein Versatz entstehen, so fahren Sie parallel bis zur obersten Position (Endschalter) und dann wieder abwärts.
- EN** The connection of both drive systems is a circuit (parallel) and it can be used when moving depending on the respective load on one or the other side of the bed for offset come during the procedure. This is not a reason for a complaint. If there is an offset, you drive parallel to the top position (limit switch) and then down again.
- FR** La connexion des deux systèmes d'entraînement est un circuit (parallèle) et il peut être utilisé lors du déplacement en fonction de la charge respective sur l'un ou l'autre côté du lit pour le décalage venir pendant la procédure. Ce n'est pas un motif de plainte. S'il y a décalage, vous roulez parallèlement à la position supérieure (interrupteur de fin de course) puis redescendez.
- NL** De verbinding van beide aandrijfsystemen is een circuit (parallel) en kan gebruikt worden bij het verplaatsen afhankelijk van de respectievelijke belasting aan de ene of de andere kant van het bed voor offset komen tijdens de procedure. Dit is geen reden voor een klacht. Als er een afwijking is, je rijdt parallel aan de bovenste stand (eindschakelaar) en dan weer naar beneden.

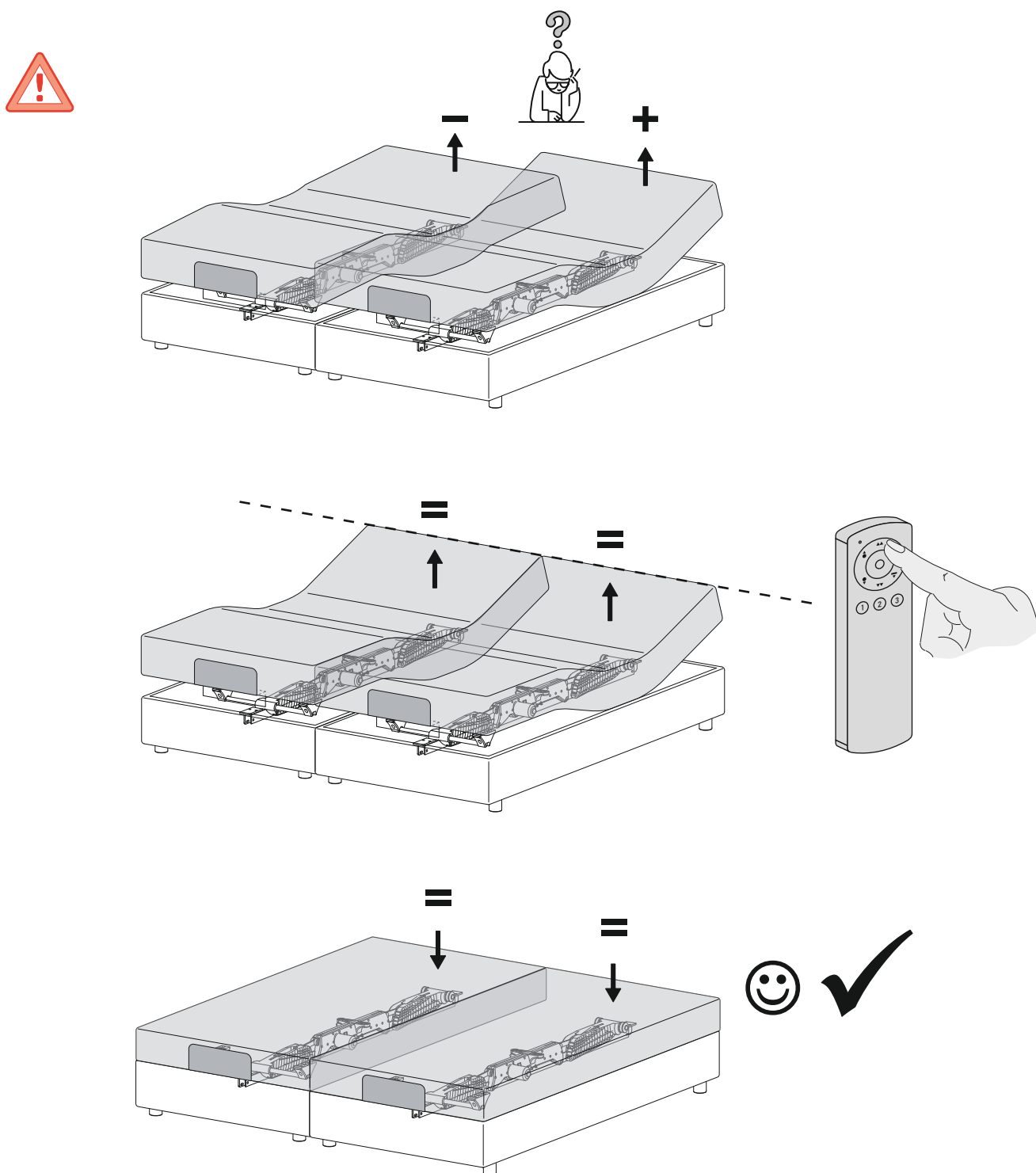

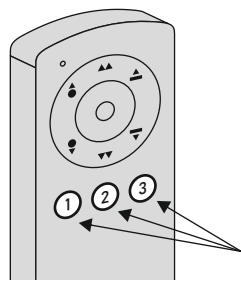

DE Memoryfunktion
EN Memoryfunction
FR Fonction mémoire
NL Memoryfunctie

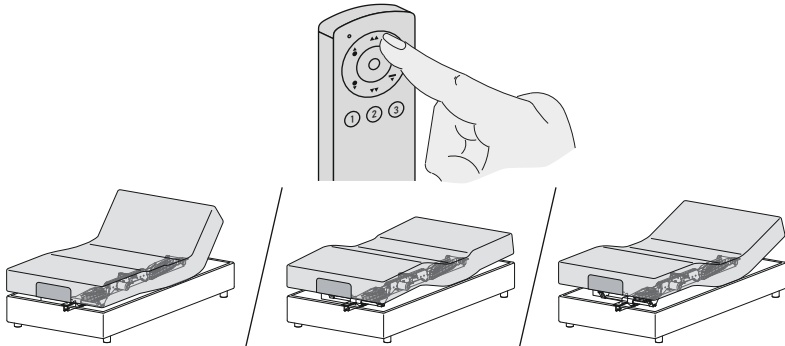

- DE** Verfahren Sie Ihr Bettsystem in die Position, welche Sie abspeichern möchten.
- EN** Move your bed system to the position you want to savewant.
- FR** Déplacez votre système de lit dans la position que vous souhaitez sauvegarder.
- NL** Verplaats uw bedsteeem naar de positie die u wilt opslaan.

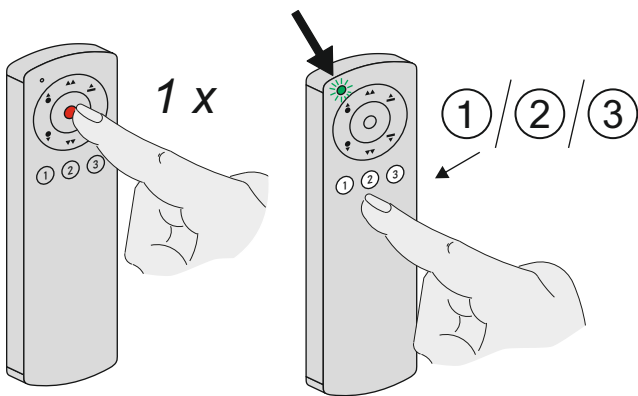

- DE** Drücken Sie die rote SET Taste am Handsender 1x (einmal) - grüne LED blinkt - und dann umgehend eine der drei (1, 2 oder 3) Speichertasten, um diese Position abzuspeichern.
- EN** Press the red SET button on the handheld transmitter 1x (once) - green LED flashes - and then immediately one of the three (1, 2 or 3) memory keys, to save this position.
- FR** Appuyez sur le bouton rouge SET de l'émetteur portatif 1x (une fois) - la LED verte clignote - puis immédiatement l'une des trois (1, 2 ou 3) touches de mémoire, pour sauvegarder cette position.
- NL** Druk op de rode SET-knop op de handzender 1x (eenmalig) - groene LED knippert - en dan onmiddellijk een van de drie (1, 2 of 3) geheugen-toetsen, om deze positie op te slaan.



- DE** Sollte eine Position auf 1, 2 oder 3 bereits gespeichert sein, so wird diese überschrieben!
- EN** If a position on 1, 2 or 3 is already saved, it will be overwritten!
- FR** Si une position sur 1, 2 ou 3 est déjà enregistré, il sera Écrasé!
- NL** Als een positie op 1, 2 of 3 al is opgeslagen, wordt het Overschreven!

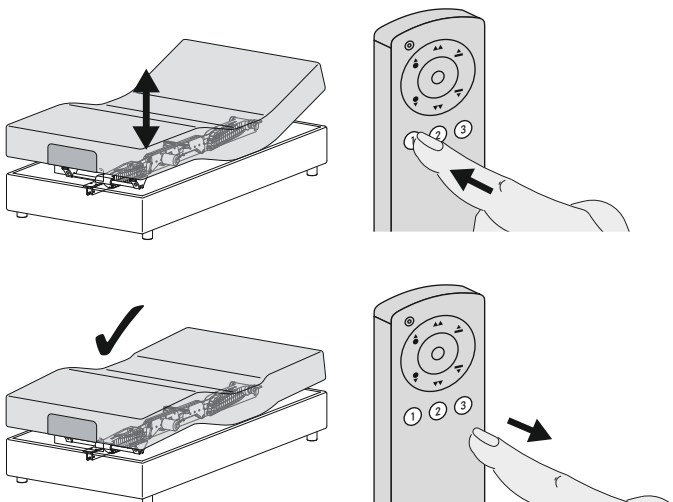

- DE** Zum Abruf der gespeicherten Position drücken Sie einfach die Taste 1, 2 oder 3. Halten Sie diese gedrückt bis das Bettsystem in die abgespeicherte Position gefahren ist und stehen bleibt.
- EN** To retrieve the saved position, just press the 1, 2 or 3 button. Press and hold the button until the bed system moves to the stored position and stops.
- FR** Pour récupérer la position enregistrée, il suffit d'appuyer sur le bouton 1, 2 ou 3. Appuyez sur le bouton et maintenez-le enfoncé jusqu'à ce que le système de lit se déplace vers la position mémorisée et s'arrête.
- NL** Om de opgeslagen positie op te halen, drukt u gewoon op de knop 1, 2 of 3. Houd de knop ingedrukt totdat het bedsteeem naar de opgeslagen positie en stopt.

- DE** Inbetriebnahme Kabelsteuerung
- EN** Commissioning cable control
- FR** Mise en service de la commande par câble
- NL** Ingebruikneming kabelbediening

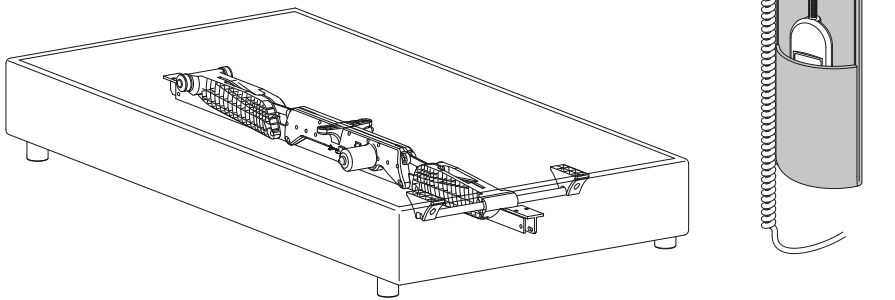

DE Vor dem Anschluss des elektrischen Antriebes an das häusliche Stromnetz, vergleichen Sie bitte die Spannung des Stromnetzes mit der auf dem Typenschild des Netzteiles angegebenen Eingangsspannung. Netzspannung und zulässige Eingangsspannung müssen identisch sein. Wenn nicht, darf der Antrieb nicht angeschlossen werden. Bitte den Femira-Service ansprechen.



EN Before connecting the electric power to the domestic circuit, please compare the voltage of the mains network with the incoming voltage on the label of the mains unit. The supply voltage and permitted incoming voltage must be the same. If they are not, then the drive is not to be connected. Please contact the Femira service department.

FR Avant le raccordement de l'entraînement électrique au secteur, comparez la tension du secteur à la tension d'entrée indiquée sur la plaque signalétique du bloc d'alimentation. La tension du secteur et la tension d'entrée admissible doivent être identiques. Si tel n'est pas le cas, l'entraînement ne doit pas être mis sous tension. Veuillez alors contacter Femira.

NL Voordat de elektrische aandrijving op het elektriciteitsnet thuis wordt aangesloten, dient u de spanning van het elektriciteitsnet te vergelijken met de op het typeplaatje van de adapter aangegeven ingangsspanning. De netspanning en de toegestane ingangsspanning moeten identiek zijn. Is dat niet het geval, dan mag de aandrijving niet worden aangesloten. Neem a.u.b. contact op met de Femira-serviceafdeling.

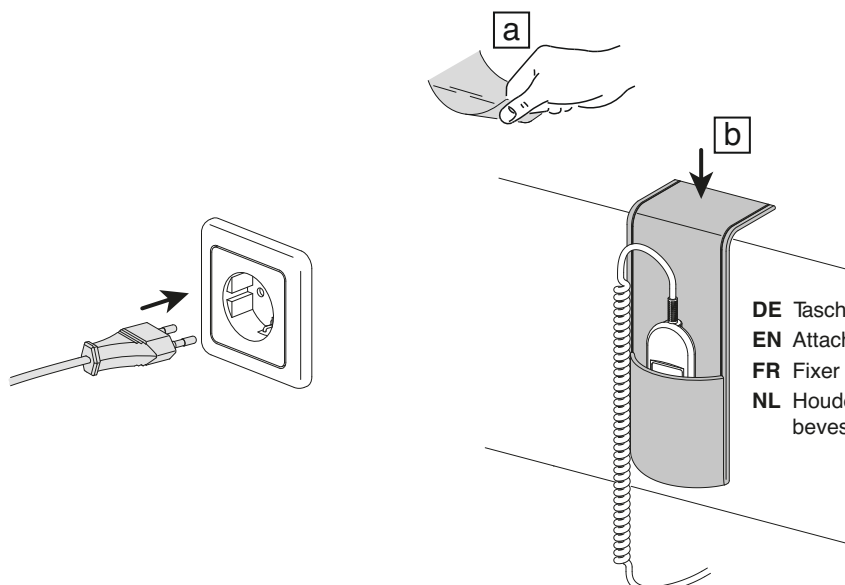
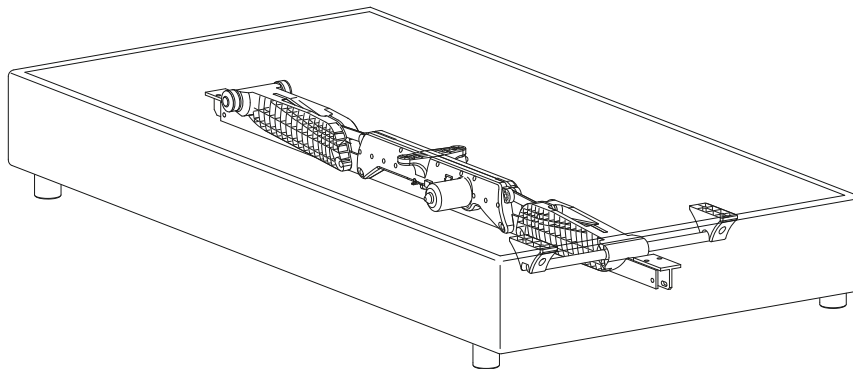

- DE** Tasche für Bedienteil befestigen.
- EN** Attach the bag for the control unit.
- FR** Fixer la housse de la commande.
- NL** Houder voor bedieningselement bevestigen.

DE Notabsenkung
 EN Emergency lowering
 FR Abaissement d'urgence
 NL Verlaging in geval

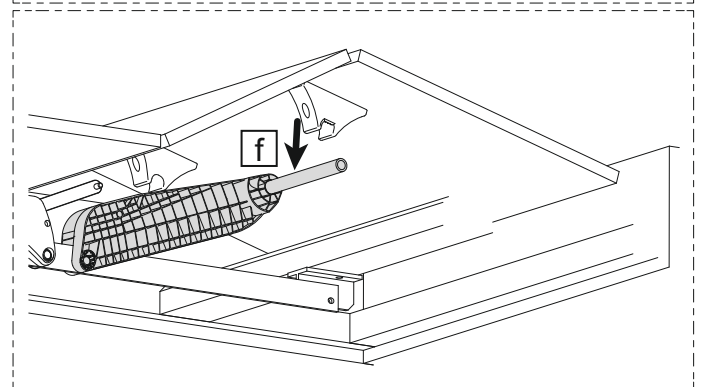
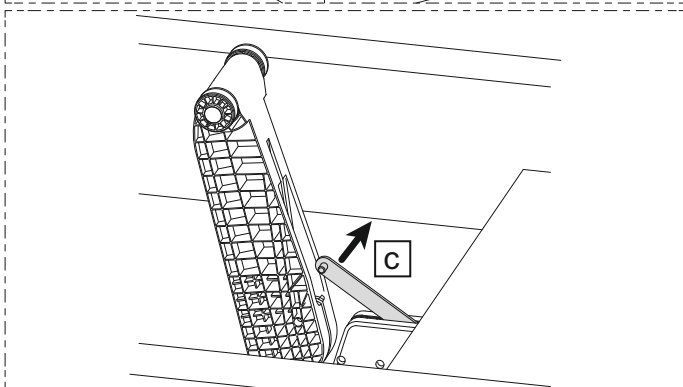
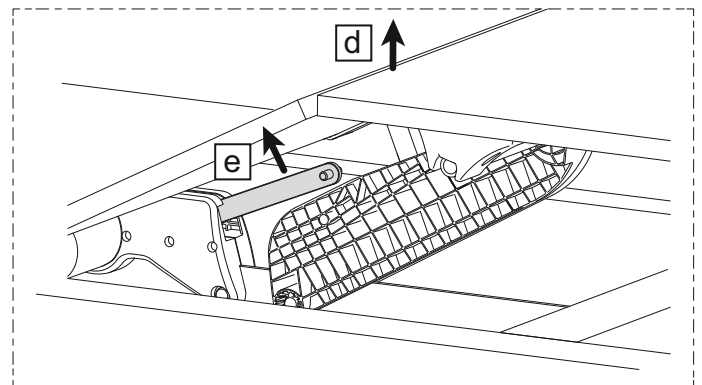
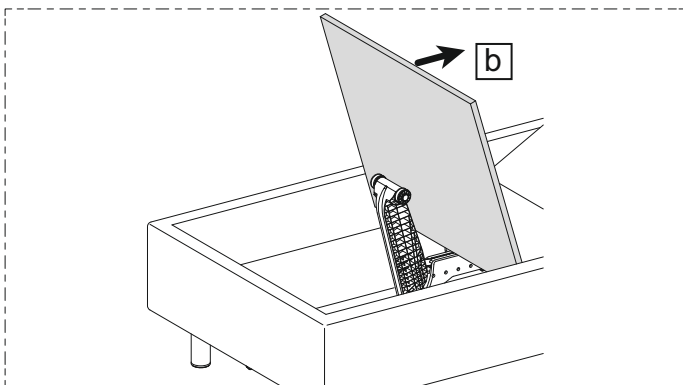
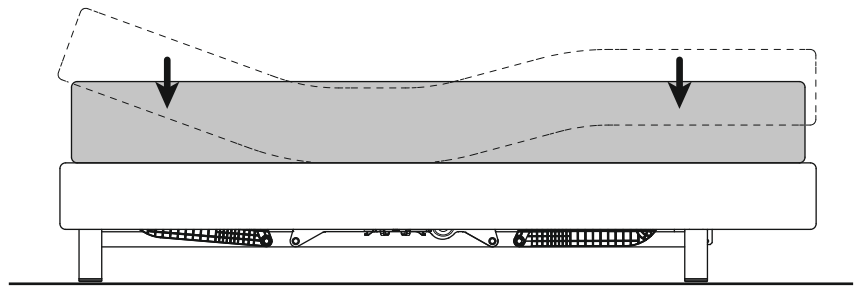
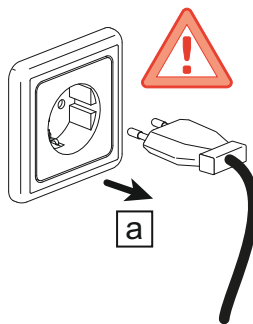
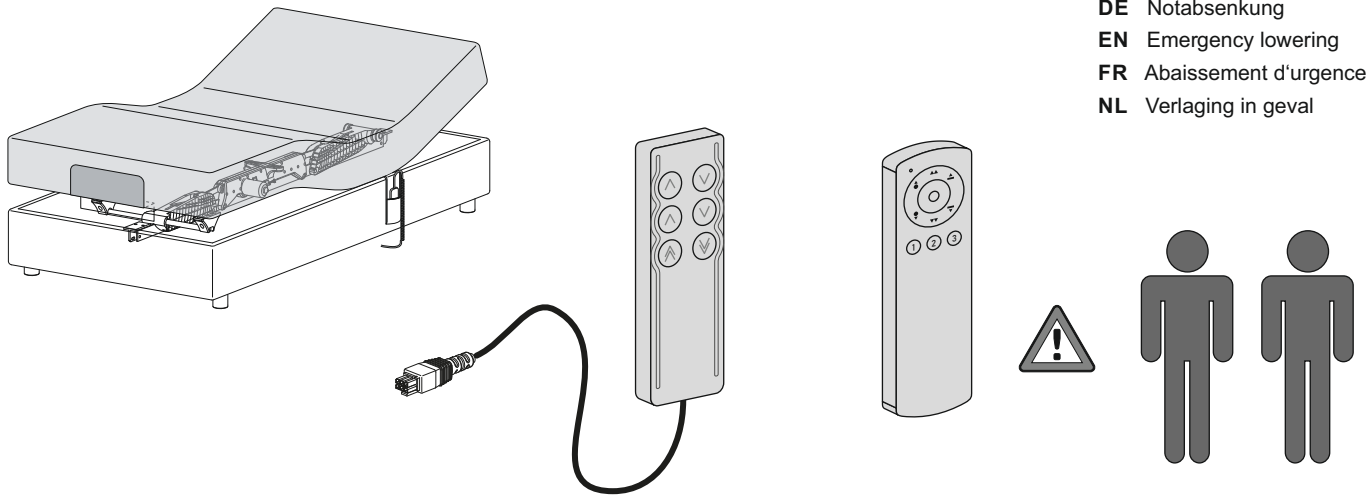

DE Vor Wiederinbetriebnahme müssen die Metallhebel wieder in die Führung eingesetzt werden!
EN Before Re-Usage the metal levers need to be inserted into the guide rail!
FR Les leviers métalliques doivent être remis en place dans le guide avant la remise en service!
NL De metalen hendels moeten voor de herinbedrijfname weer in de geleider worden geplaatst!

DE DEMONTAGE Motor
 EN DISMANTLING the motor
 FR DÉMONTAGE du moteur
 NL DEMONTAGE motor

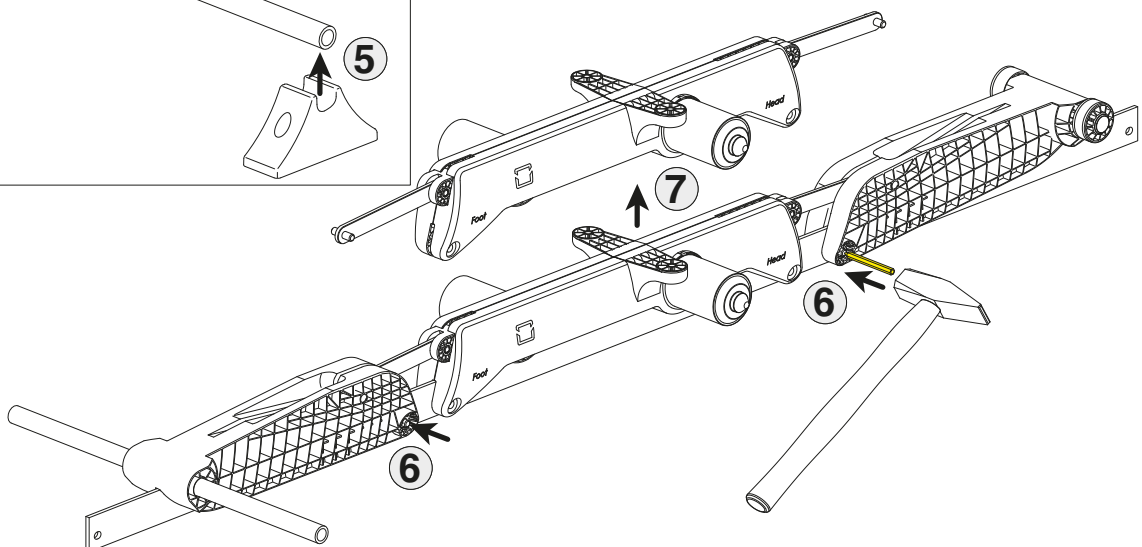
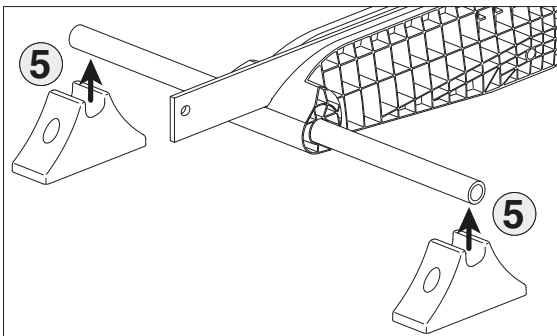
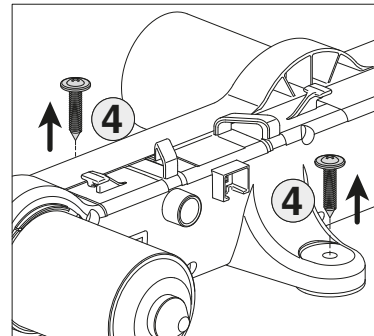
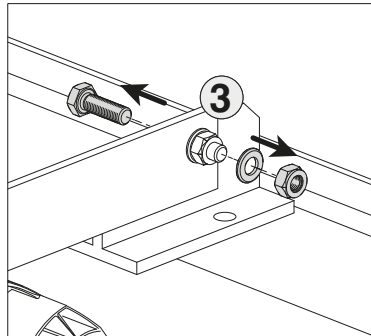
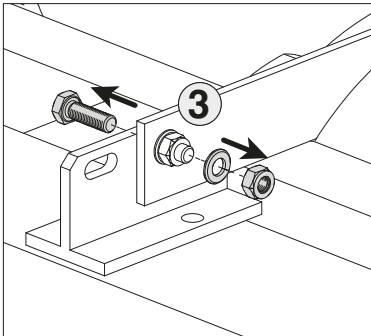
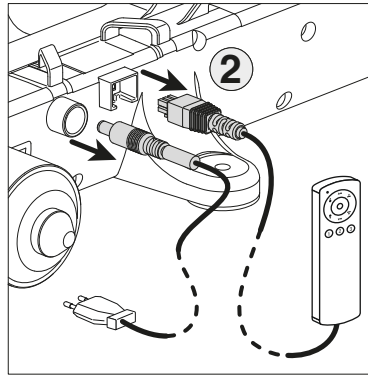
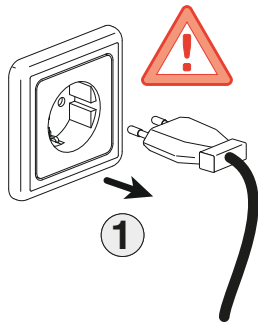
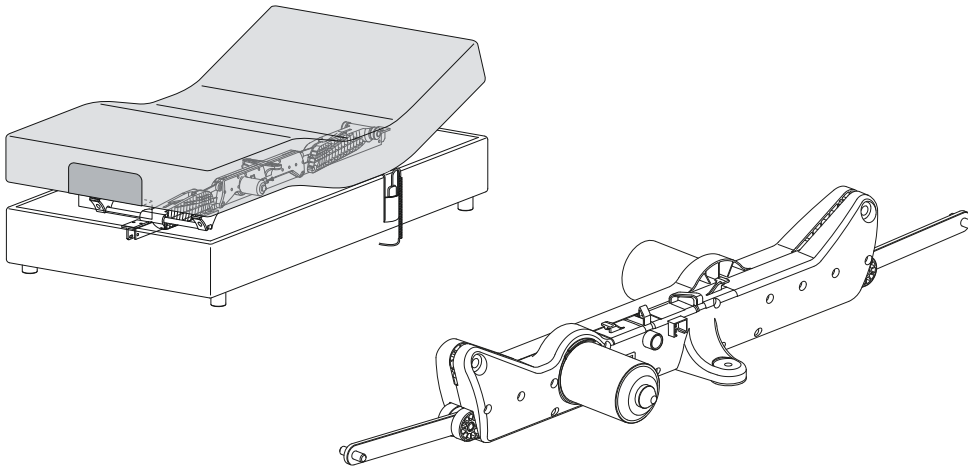

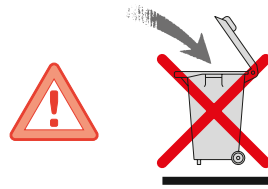

DE Recycling / Entsorgung

Die Recycling- oder Entsorgungsmöglichkeiten von motorischen Federholzrahmen und BOXSPRING Betten sind länderspezifisch geregelt. Bitte informieren Sie sich bei Ihrer zuständigen Behörde oder fragen Sie Ihren Fachhändler.

Die Kabel-/Funksteuerung enthält Elektronikbauteile, Kabel, Metalle, Kunststoffe usw.

Die Teile der Steuerung sind gemäß den geltenden Umweltvorschriften des jeweiligen Landes zu entsorgen.

Die Entsorgung der Kabel-/Funksteuerung unterliegt in Deutschland dem Elektro-G, international der EU-Richtlinie 2002/95/EG (RoHS ab dem 01.07.2006) und Richtlinie 2011/65/EU (RoHS ab 03.01.2013) oder den jeweiligen nationalen Gesetzgebungen. (Die Steuerung unterliegt nicht der EU-Richtlinie 2002/96/EG (WEEE) und deren Ergänzung EU-Richtlinie 2003/108/EG.)

Die Teile der Kabel-/Funksteuerung dürfen nicht in den Hausmüll gelangen! Die Entsorgung der Blockbatterien unterliegt in der EU der Batterierichtlinie 2006/66/EG, in Deutschland dem Batteriegesetz (BattG) vom 25.06.2009, international den jeweiligen nationalen Gesetzgebungen.

Die Blockbatterien (9V, 6LR61) und die Batterien TYPE AAA, 1,5V, LR03 Alkaline dürfen nicht in den Hausmüll gelangen!

EN Recycling / disposal

The recycling and disposal options for motorised sprung wood frames and BOX SPRING beds vary from country to country. Please contact your local authority or speak to your specialist retailer.

The cable / remote control contains electronic components, cables, metals, plastics etc. The various components in the control are to be disposed of in accordance with your country's applicable environmental regulations.

In Germany, the disposal of the cable / remote control is subject to Elektro-G, and internationally to EU Guideline 2002/95/EG (RoHS of 01.07.2006) and Guideline 2011/65/EU (RoHS of 03.01.2013) or the respective national legislation. (The control is not subject to EU Guideline 2002/96/EG (WEEE) and its amendment EU Guideline 2003/108/EG.)

The components of the cable / remote control unit are not to be put in with domestic waste! Disposal of the block batteries in the EU is subject to Battery Guideline 2006/66/EG, in Germany to the Battery Act (BattG) of 25.06.2009, and internationally to each country's national legislation.

The block batteries (9V, 6LR61) and batteries type AAA, 1.5V, LR03 alkaline, are not to be put in the domestic waste!

FR Recyclage / Mise au rebut

Les possibilités de recyclage ou de mise au rebut des sommiers à lattes motorisés et des lits BOXSPRING varient selon les pays. Veuillez vous informer auprès des autorités compétentes ou de votre revendeur.

La commande par câble / la radio-commande contient des composants électroniques, des câbles, des métaux, des matières synthétiques, etc. Les composants de la commande doivent être mis au rebut conformément aux dispositions environnementales en vigueur dans le pays concerné.

La mise au rebut de la commande par câble / de la radio-commande est soumise en Allemagne à la disposition ElektroG, dans le reste du monde à la directive de l'UE 2002/95/CE (RoHS à compter du 01/07/2006) et à la directive 2011/65/UE (RoHS à compter du 03/01/2013) ou aux différentes législations nationales en vigueur (La commande n'est pas soumise à la directive de l'UE 2002/96/CE (DEEE), ni à son complément la directive UE 2003/108/CE.)

Les composants de la commande par câble / de la radio-commande ne doivent pas être jetés avec les déchets ménagers! La mise au rebut des piles est soumise au sein de l'UE à la directive sur les piles 2006/66/CE, en Allemagne à la loi sur les piles (BattG) du 25/06/2009 et dans le reste du monde aux législations nationales en

Les piles TYPE AAA, 1,5V, LR03 alcalines ne doivent pas être mises au rebut avec les déchets ménagers!

NL Recycling / afvalverwijdering

De mogelijkheden voor recycling of afvalverwijdering bij elektrisch werkende lattenbodems en BOXSPRING-bedden zijn per land anders geregeld. Informeer hiernaar bij uw gemeente of vraag uw vakhandelaar om advies.

De afstands-/kabelbediening bevat elektrische componenten, kabels, metaal, kunststof enz. De onderdelen van de bediening moeten conform de in het land geldende milieuriichtlijnen worden verwijderd.

Op de afvalverwijdering van de afstands-/kabelbediening is in Duitsland richtlijn Elektro-G en internationaal de EU-richtlijn 2002/95/EG (RoHS vanaf 1-7-2006) en richtlijn 2011/65/EU (RoHS vanaf 3-1-2013) of de betreffende nationale wetgeving van toepassing.

(De bediening valt niet onder EU-richtlijn 2002/96/EG (WEEE) en de aanvulling hierop EU-richtlijn 2003/108/EG.)

De componenten van de afstands-/kabelbediening horen niet bij het huisvuil! Voor het verwijderen van blokbatterijen geldt in de EU batterijrichtlijn 2006/66/EG, in Duitsland de batterijwet (BattG) d.d. 25-6-2009 en internationaal de overeenkomstige nationale wetge.

De blokbatterijen (9V, 6LR61) en de batterijen type AAA, 1,5V, LR03 alkaline mogen niet bij het huisvuil terecht komen!

NOTIZEN

femira[®]

femira Bettensysteme GmbH & Co. KG - Daimlerstraße 2-4 - DE-33442 Herzebrock-Clarholz

phone: +49 (0) 52 45 - 9240 - 0 - mail: info@femira.de - web: www.femira.de
