

# A186-1

AUFBAUANLEITUNG - ASSEMBLY INSTRUCTION

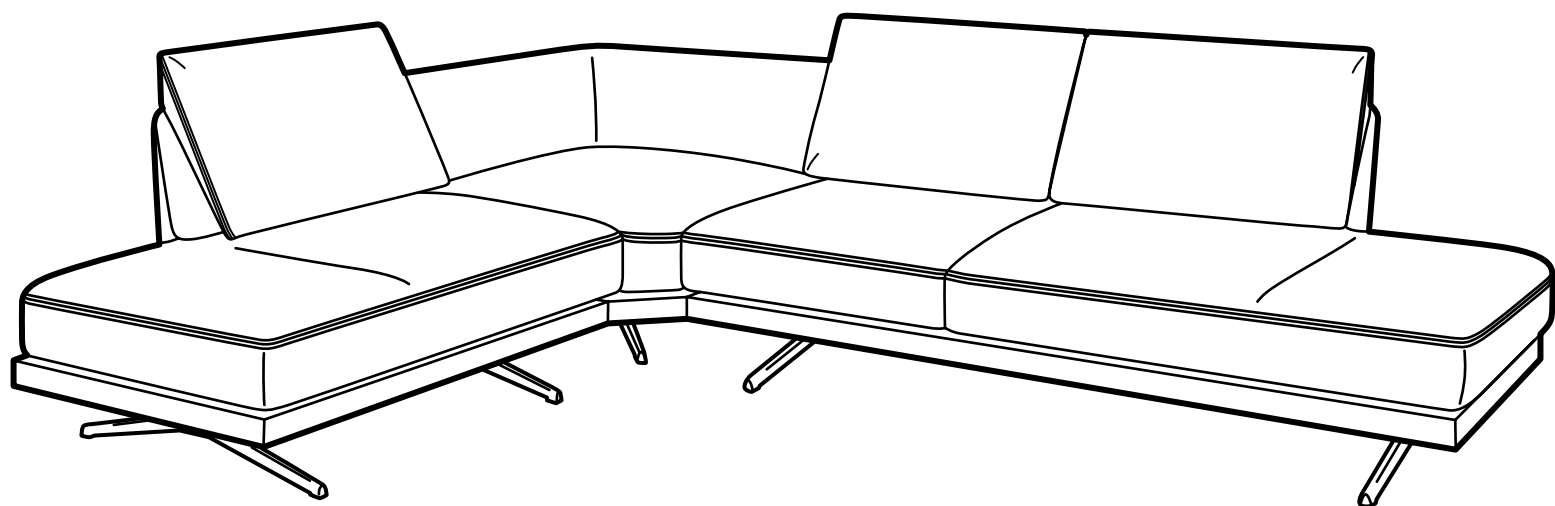



U-Scheibe **22 mm**  
Plain washer **22 mm**

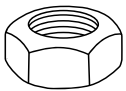

Mutter **M 8**  
Nut **M 8**

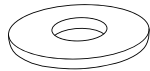

U-Scheibe **8,5 mm**  
Plain washer **8.5 mm**

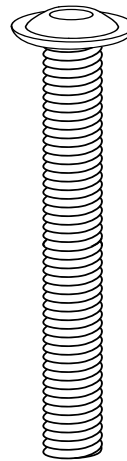

Flanschkopfschraube **8x60 mm**  
Flange head screw **8x60 mm**

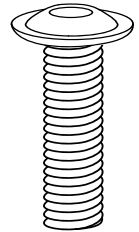

Flanschkopfschraube **8x30 mm**  
Flange head screw **8x30 mm**



Spaxschraube **5x40 mm**  
Spax screw **5x40 mm**



Gewindestift **8x60 mm**  
Setscrew **8x60 mm**



Gewindestift **8x110 mm**  
Setscrew **8x110 mm**



Gewindestift **8x120 mm**  
Setscrew **8x120 mm**

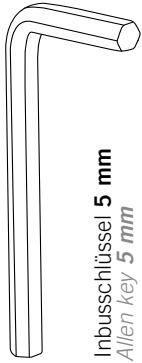

Inbusschlüssel **5 mm**  
Allen key **5 mm**

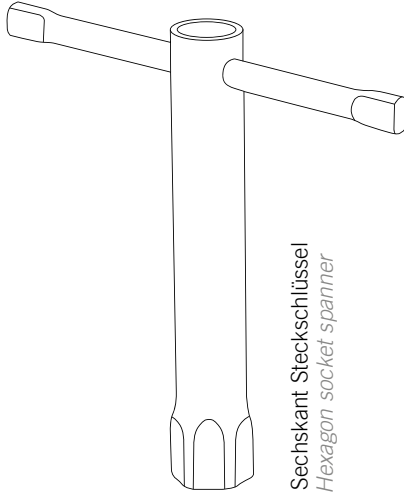

Sechskant Steckschlüssel  
Hexagon socket spanner

Plateauverbindung - Plateau connection

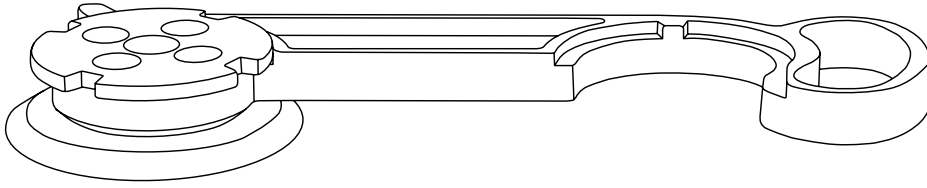

Elementverbinder  
Element connector

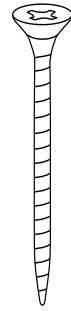

Spaxschraube 5x40 mm  
Spax screw 5x40 mm

Montageplatte für Elementverbindung / Mounting plate for element connection

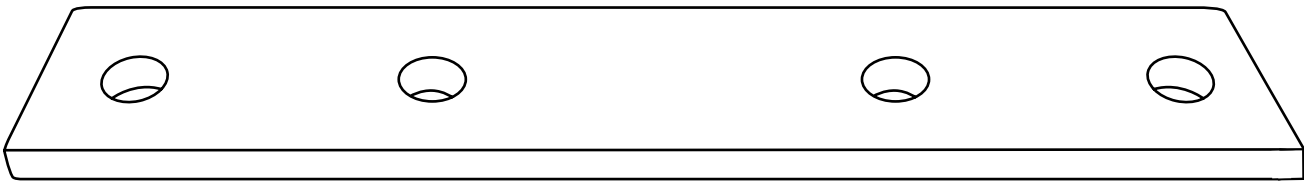

Montageplatte 210x40 mm  
Mounting plate 210x40 mm

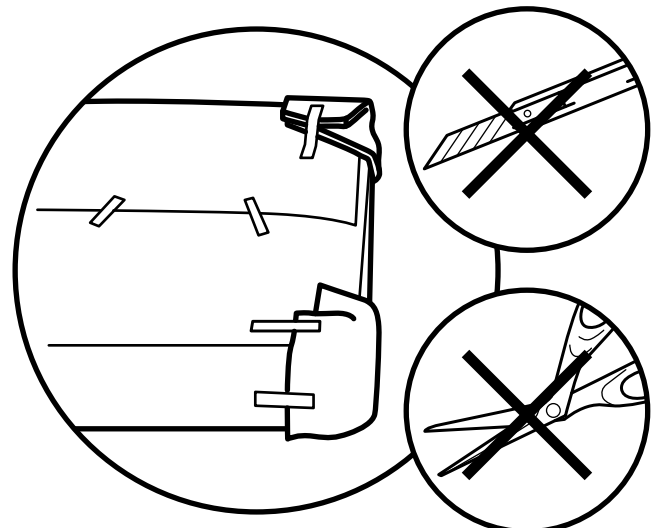
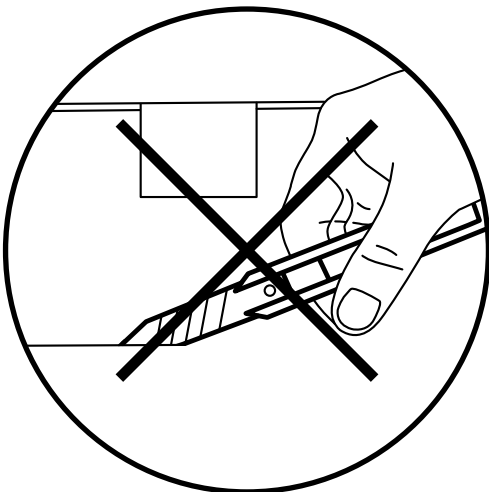
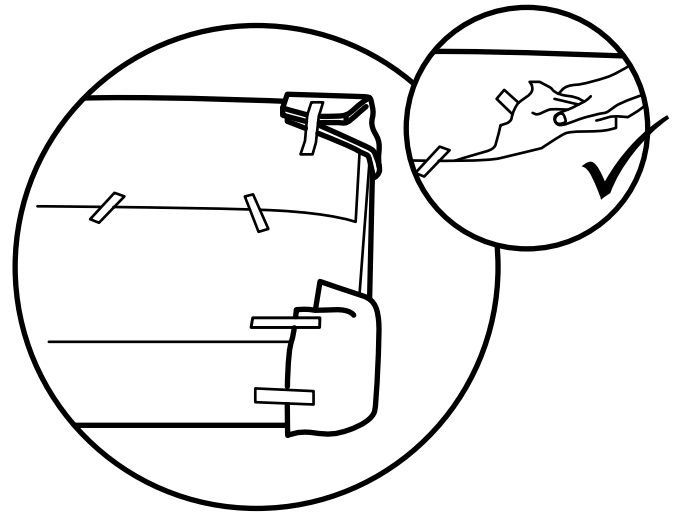
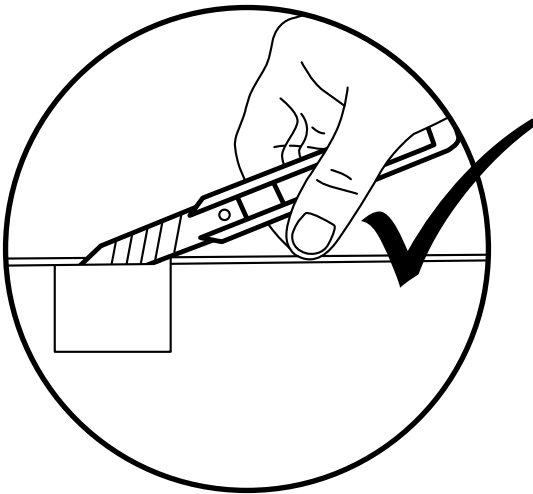

**! Hinweis / Note:**

Für den Aufbau werden zwei Monteure benötigt. Somit vermeiden Sie Beschädigungen im Vorfeld.

*Two persons are needed for the assembly. This prevents damage in advance.*

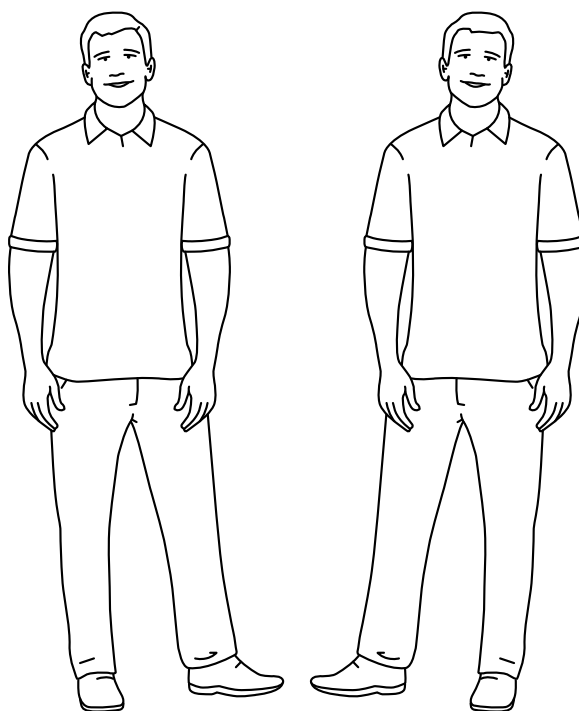

**1 Montage Plateau / Platform assembly**

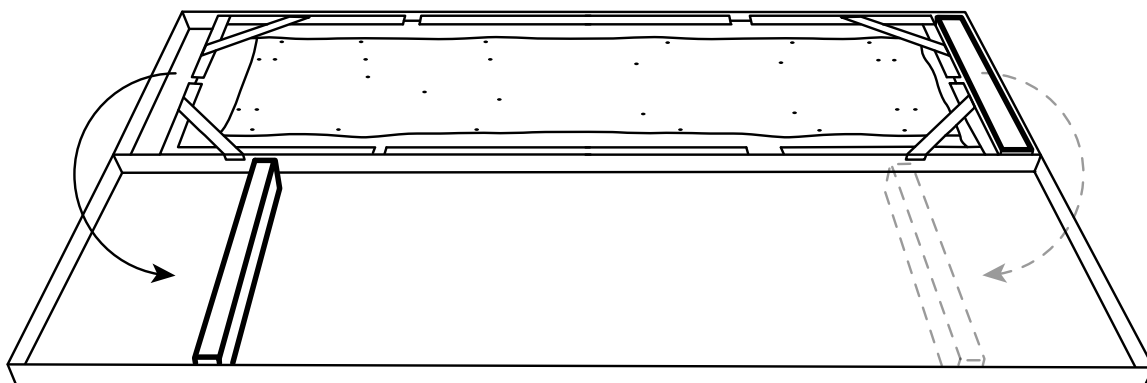

**2**

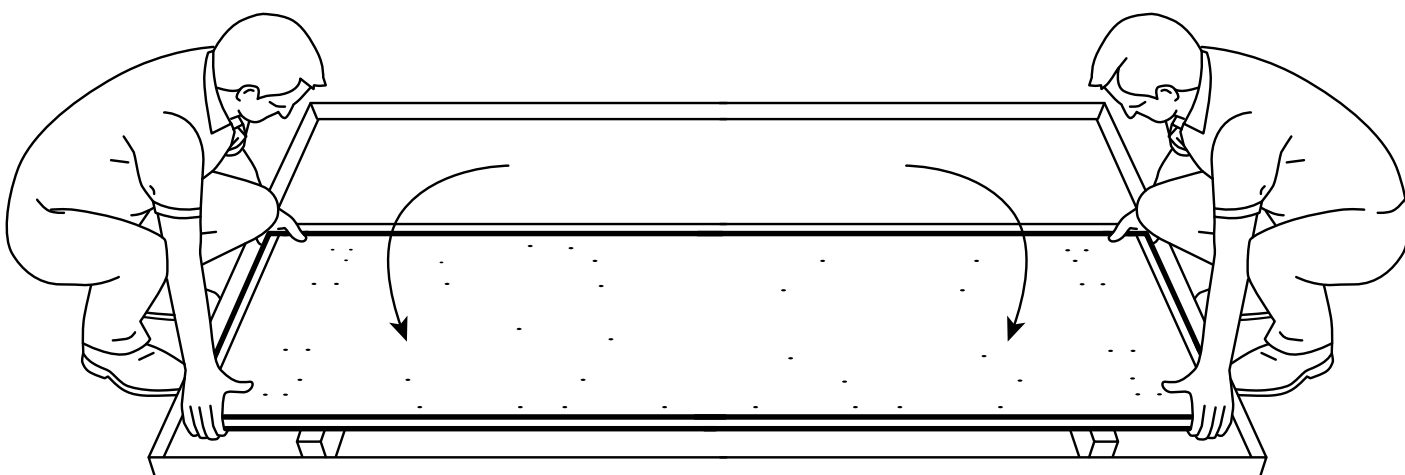

3

Flanschkopfschraube **8x60 mm**  
Flange head screw **8x60 mm**

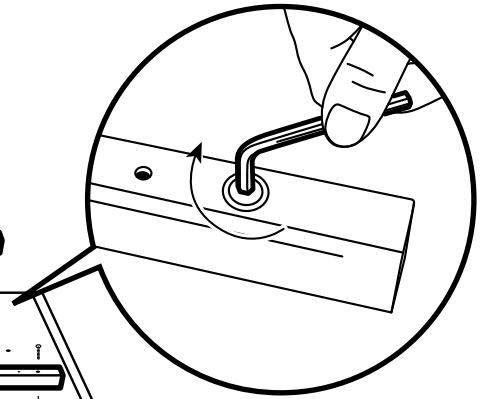
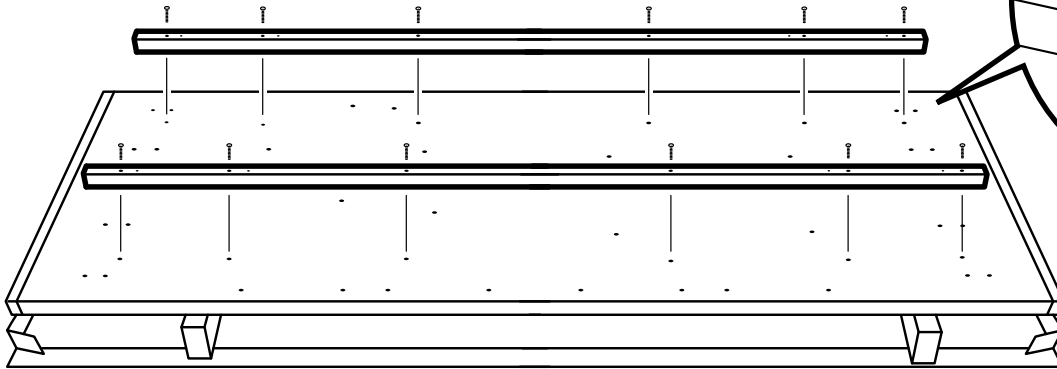
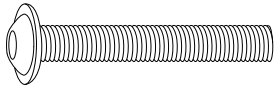

4

Flanschkopfschraube **8x30 mm**  
Flange head screw **8x30 mm**

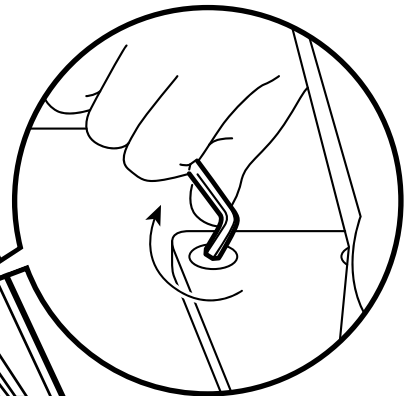
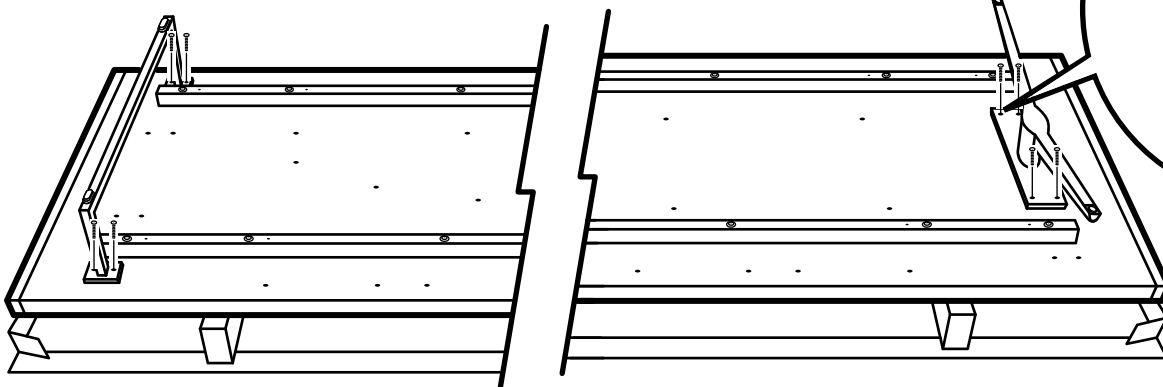
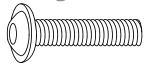

4-Kant Metallkufe  
Metal square-cut runner

Schwertkufe  
Aluminium casting sword runner

5 Flanschkopfschraube **8x30 mm**  
Flange head screw **8x30 mm**  
8x 

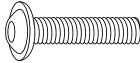
Flanschkopfschraube **8x30 mm**  
Flange head screw **8x30 mm**  
4x 

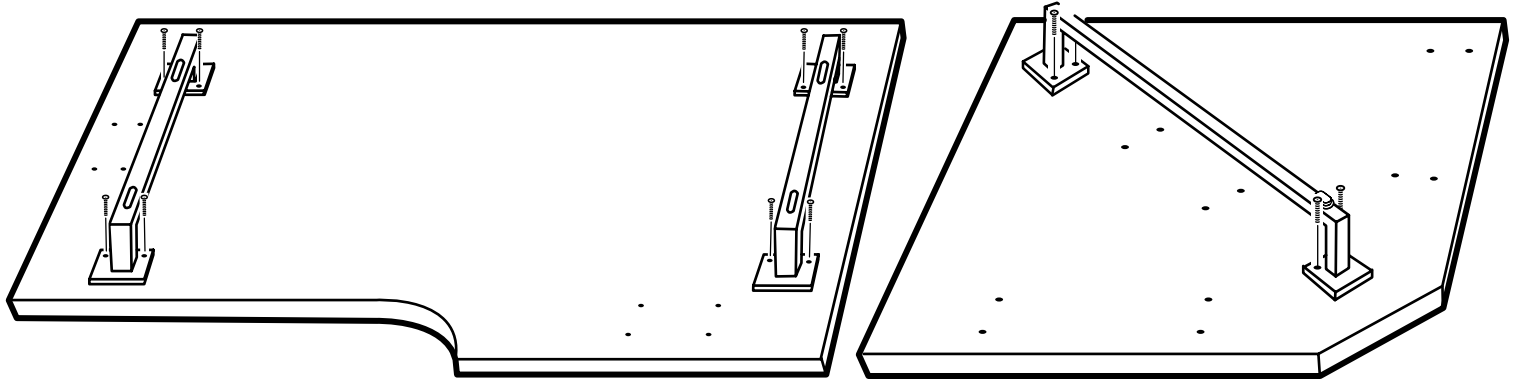

Nur bei den Elementen G - GH / Only for elements G - GH.

6 **Plataukombinationen - Vorbereitung**  
Plateau combinations - preparation

Elementverbinder  
Element connectors

Spax screw **5x40 mm**  
Spaxschraube **5x40 mm**

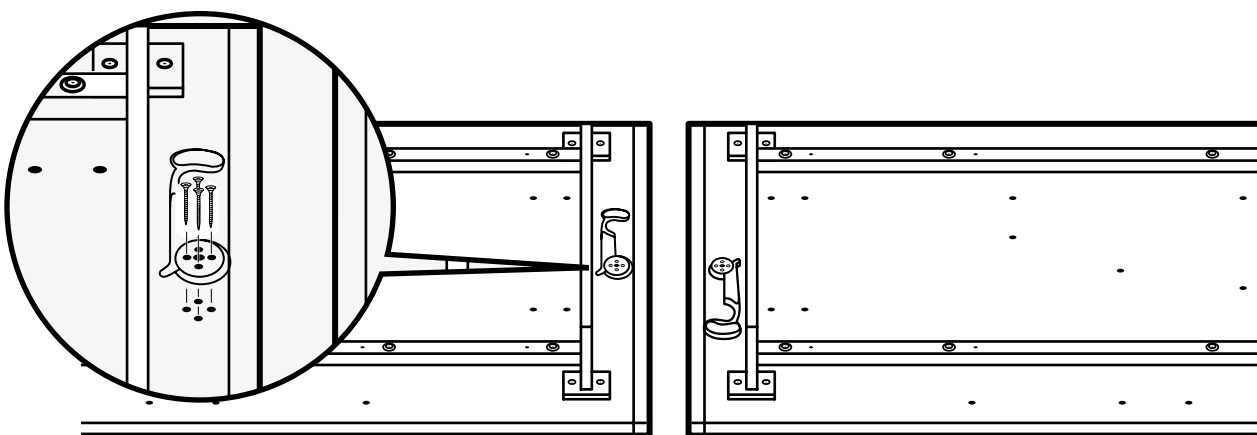

7 Plateau umdrehen und ausrichten! / Turn plateau over and align!

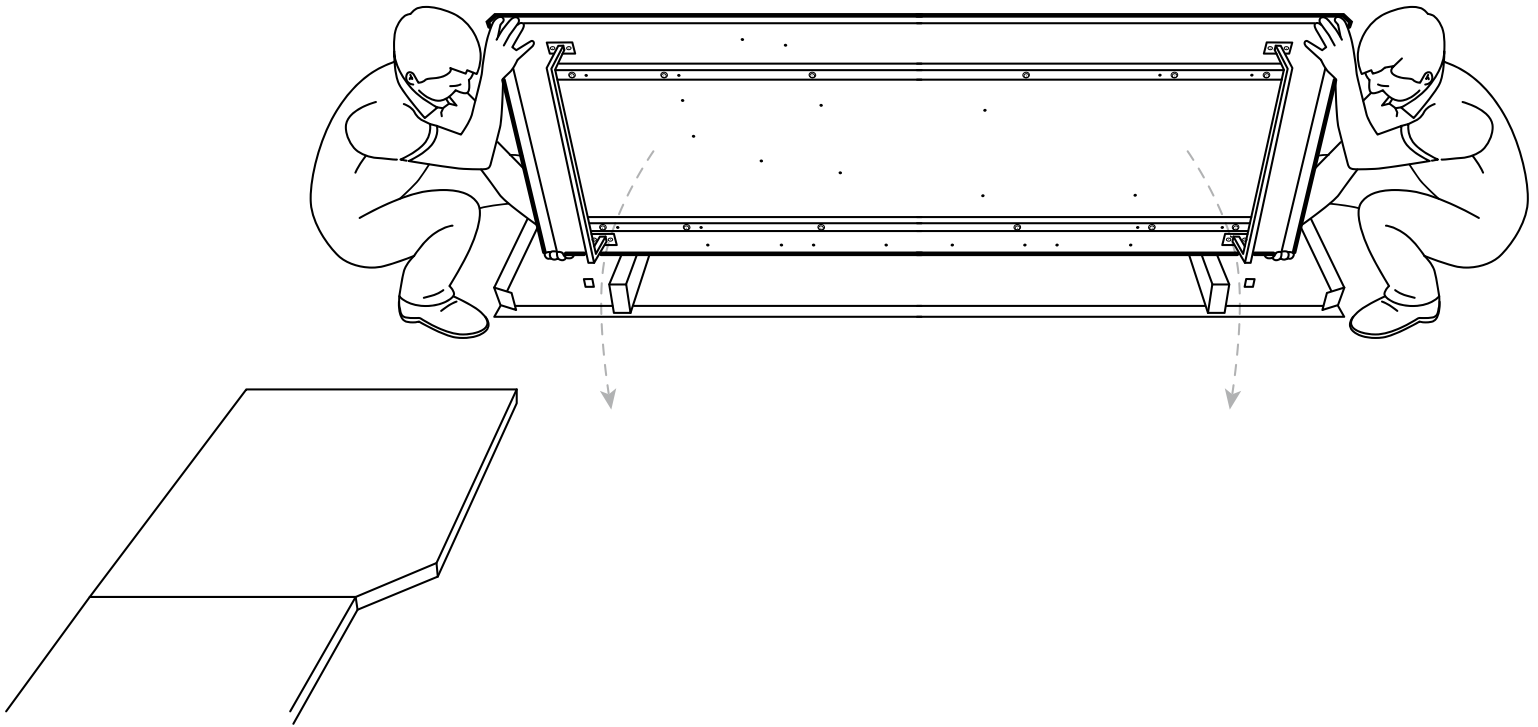

8 Flanschkopfschraube **8x30 mm**  
Flange head screw **8x30 mm**

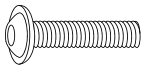

Montageplatte **210x40 mm**  
Mounting plate **210x40 mm**

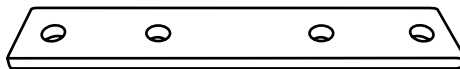

Nur bei den Elementen GL / GR *Only for elements GL / GR*

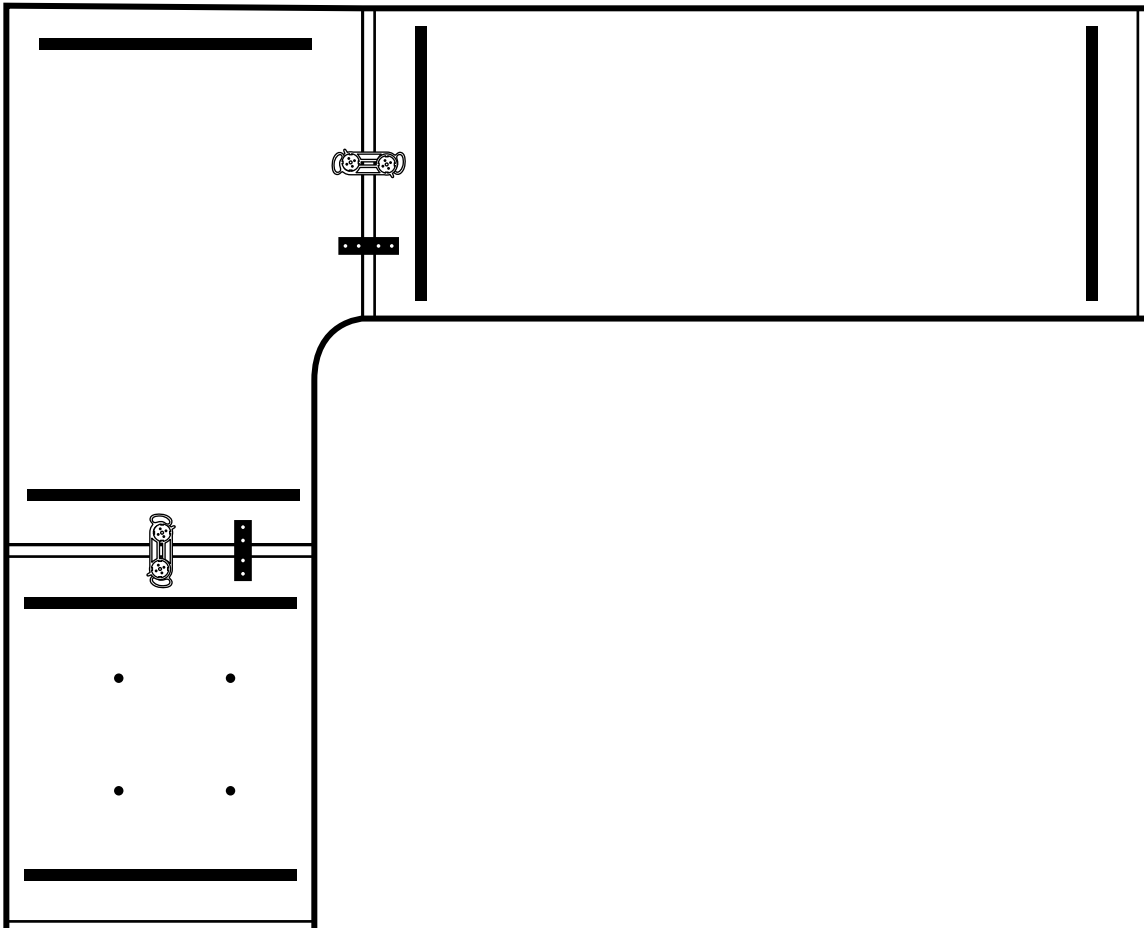

Nur bei den Elementen G / GS / GH / GSH / *Only for elements G / GS / GH / GSH.*

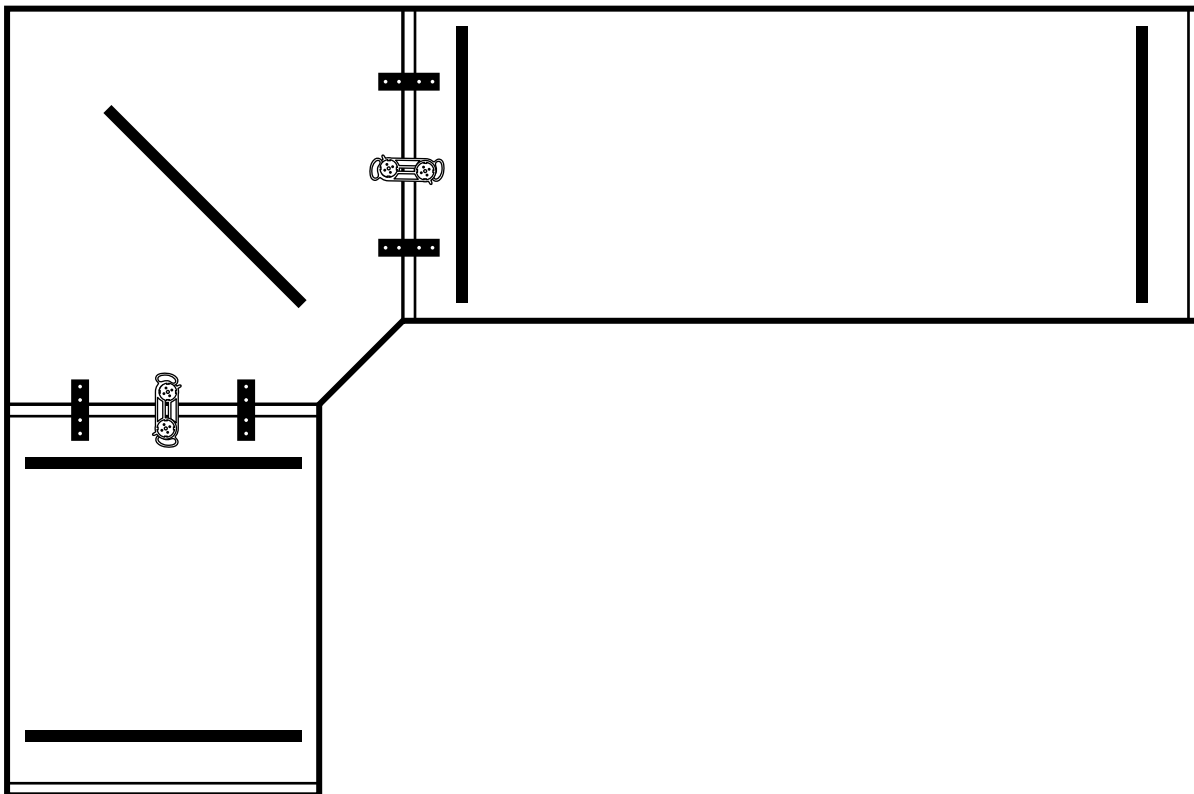

9

Plateaukombinationen – Finalisierung / *Plateau Combinations - Finalization*

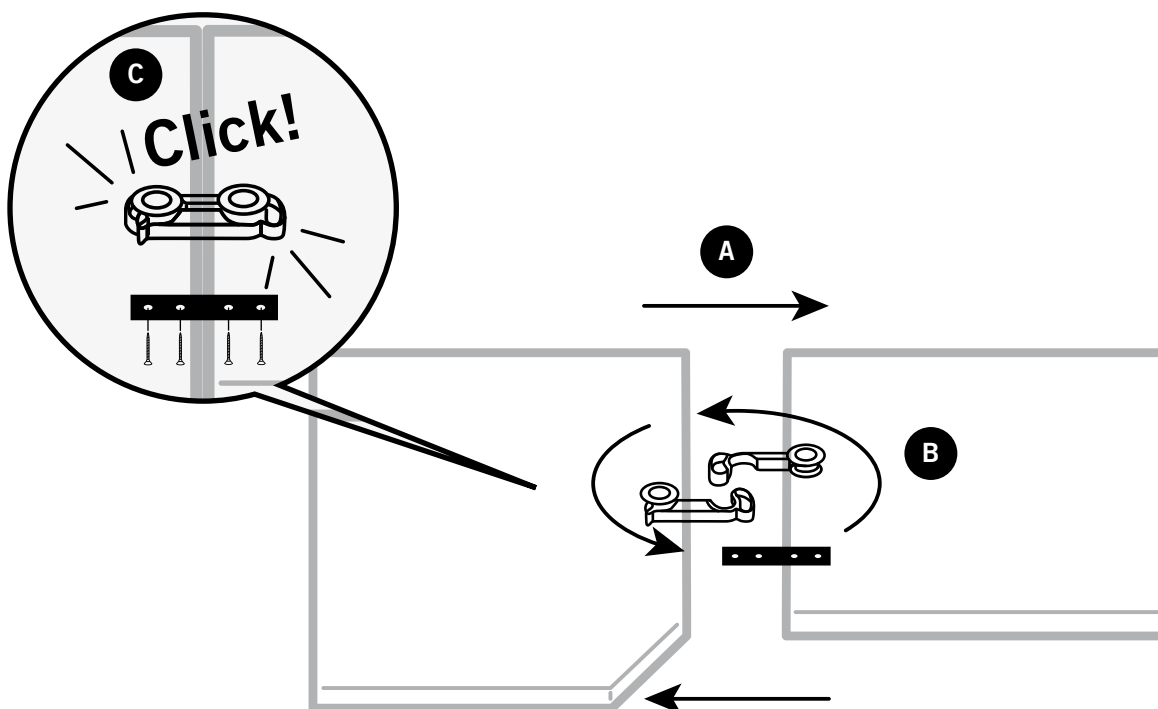



U-Scheibe 22 mm  
Plain washer 22 mm

7+

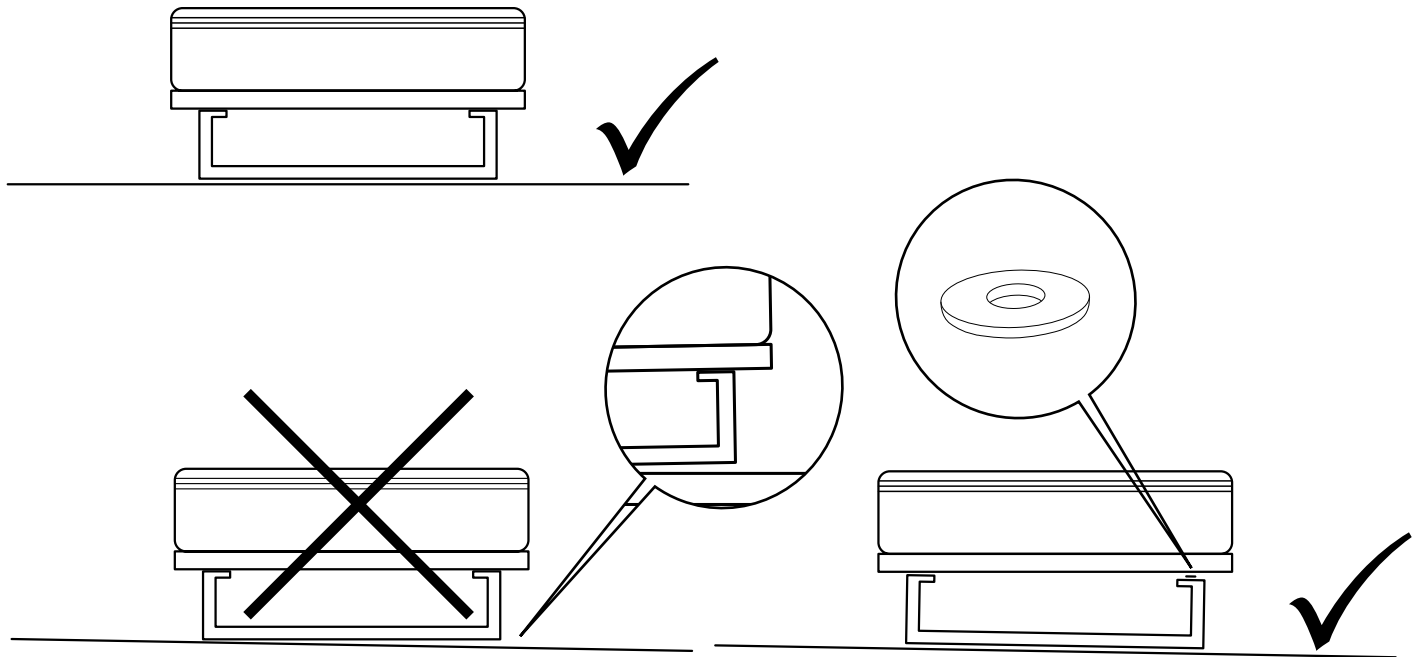

**10** Montage Sitzpolster, Festes Element / *Seat cushion assembly, fixed element*



Gewindestift 8x110 mm  
Setscrew 8x110 mm

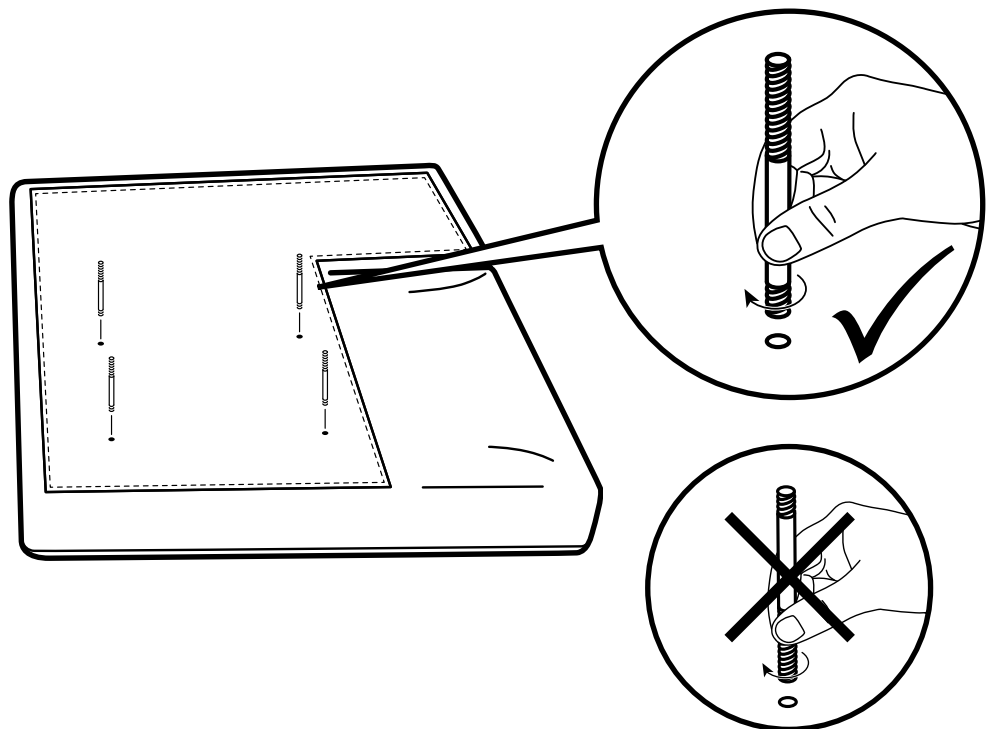

11

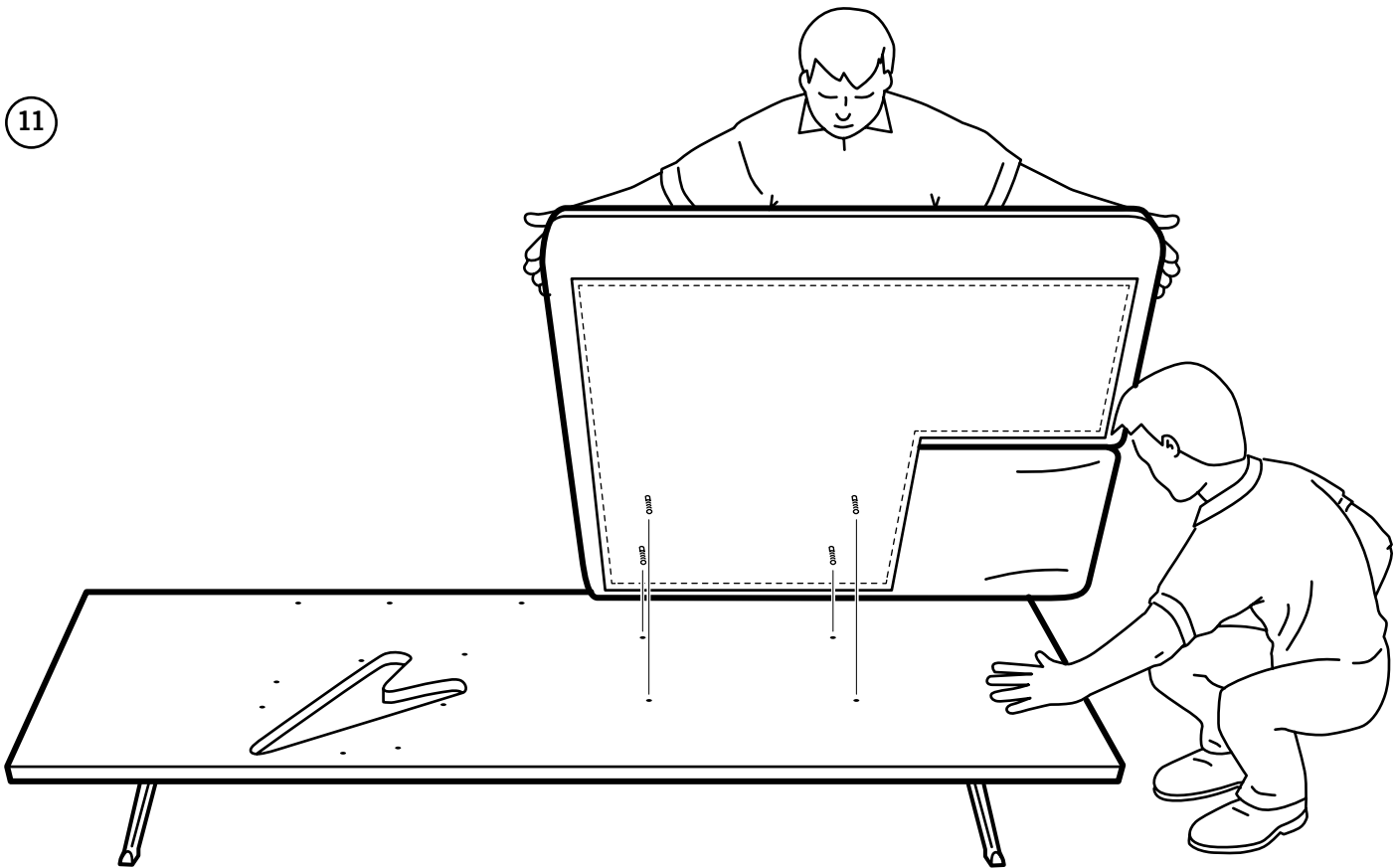

12



Mutter **M 8**  
Nut **M 8**

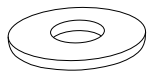

U-Scheibe **8,5mm**  
Plain washer **8.5 mm**

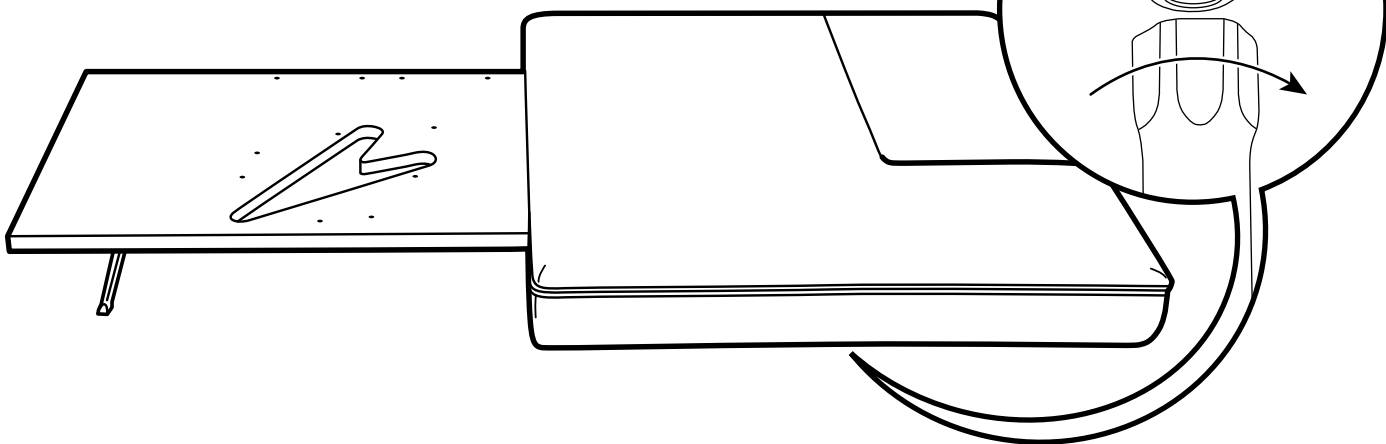

13

Montage Sitzpolster, Schwenkelement / *Seat cushion assembly, swivel element*

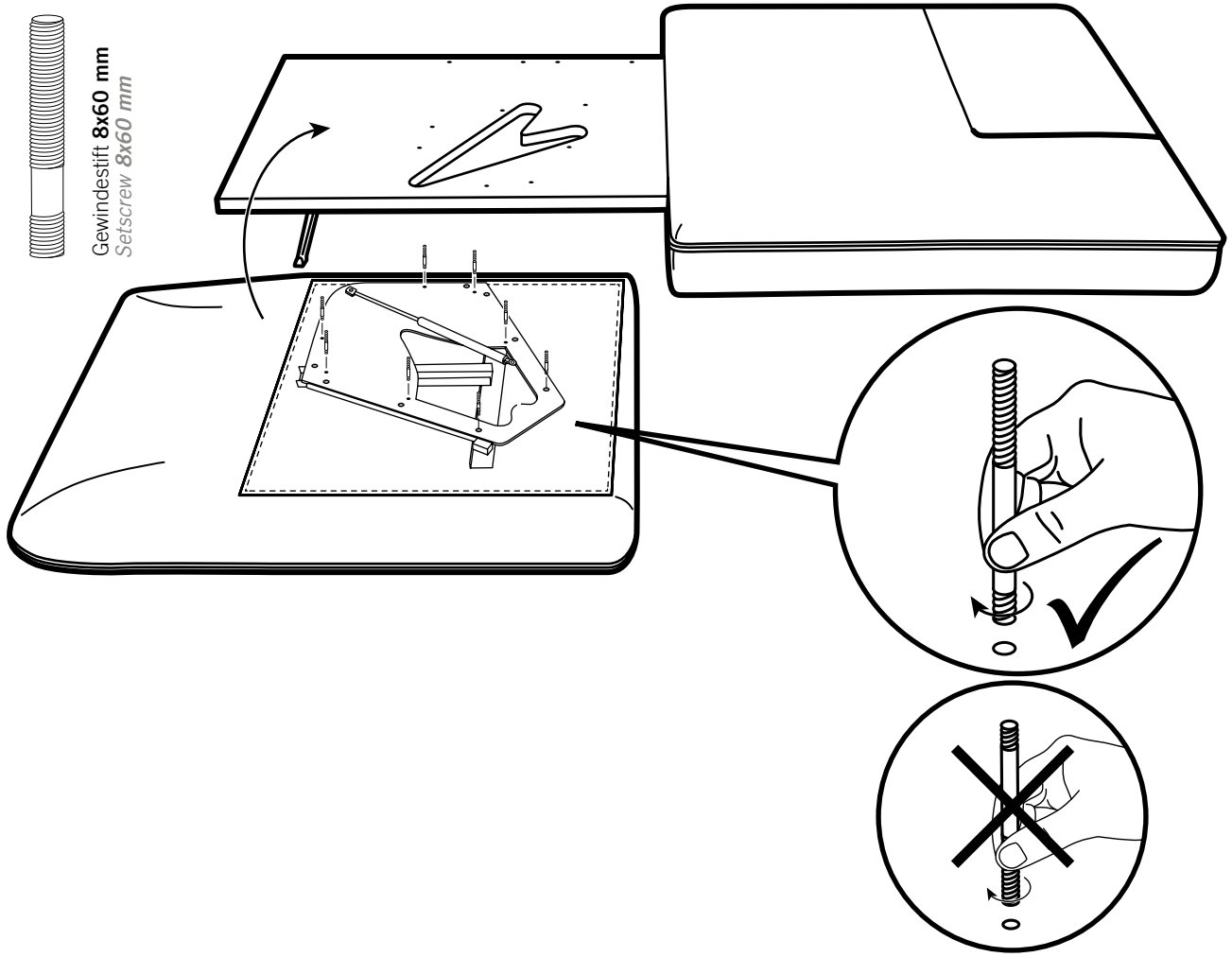

14

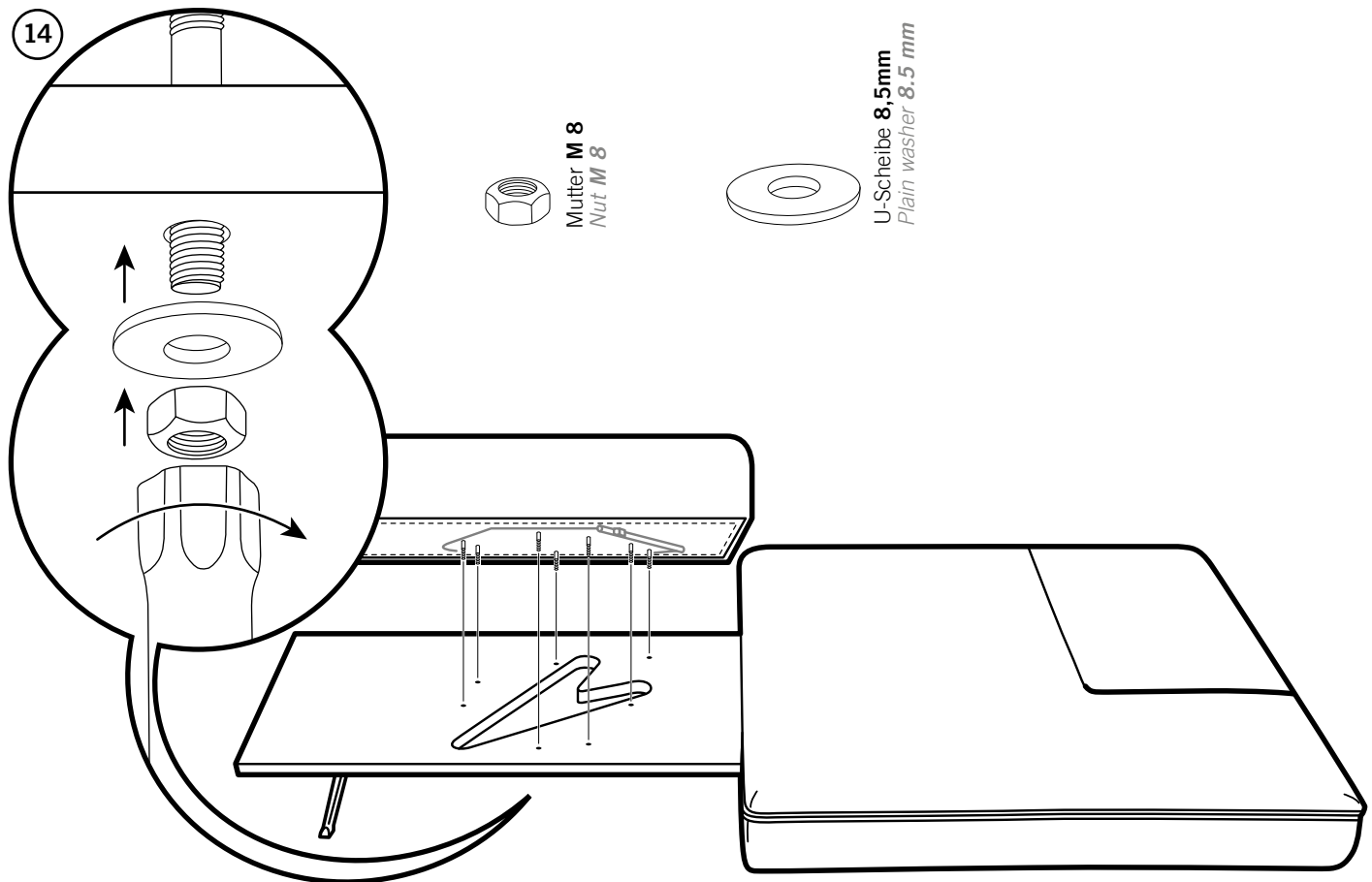

15 Montage Sitzpolster, Drehelement / *Seat cushion assembly, rotary element*

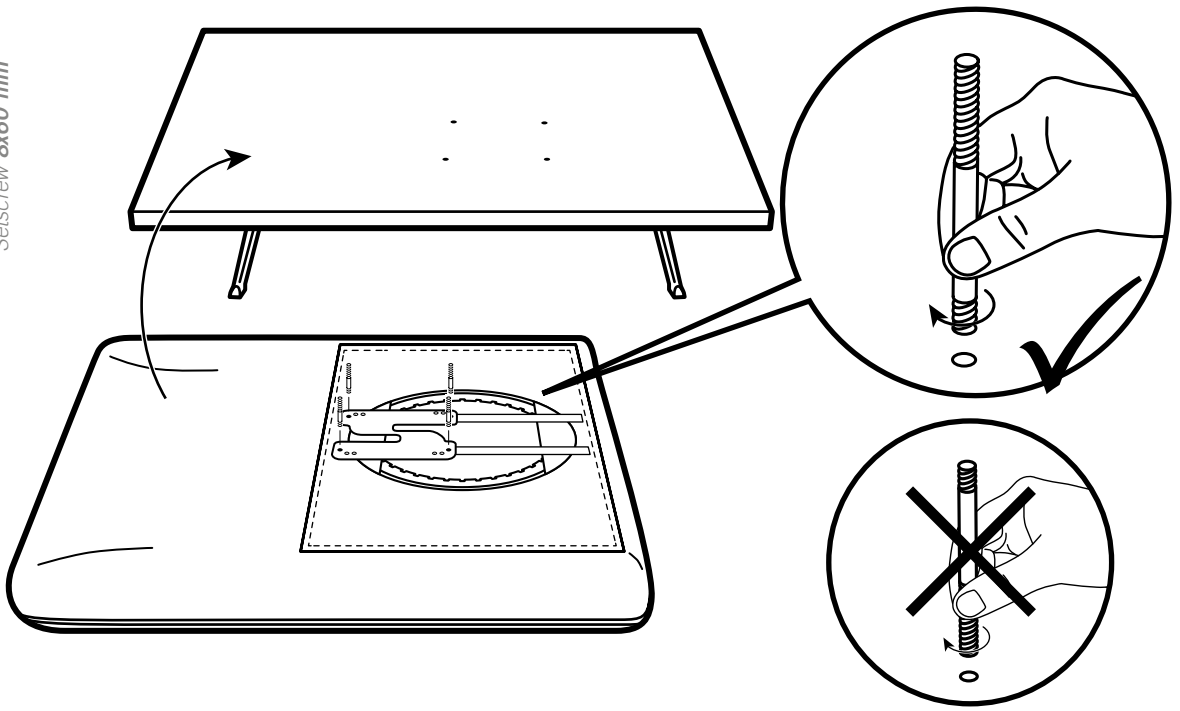
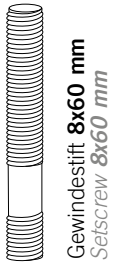

15+ Montage Sitzpolster, Drehelement Longchair / *Seat cushion assembly, rotary element longchair*

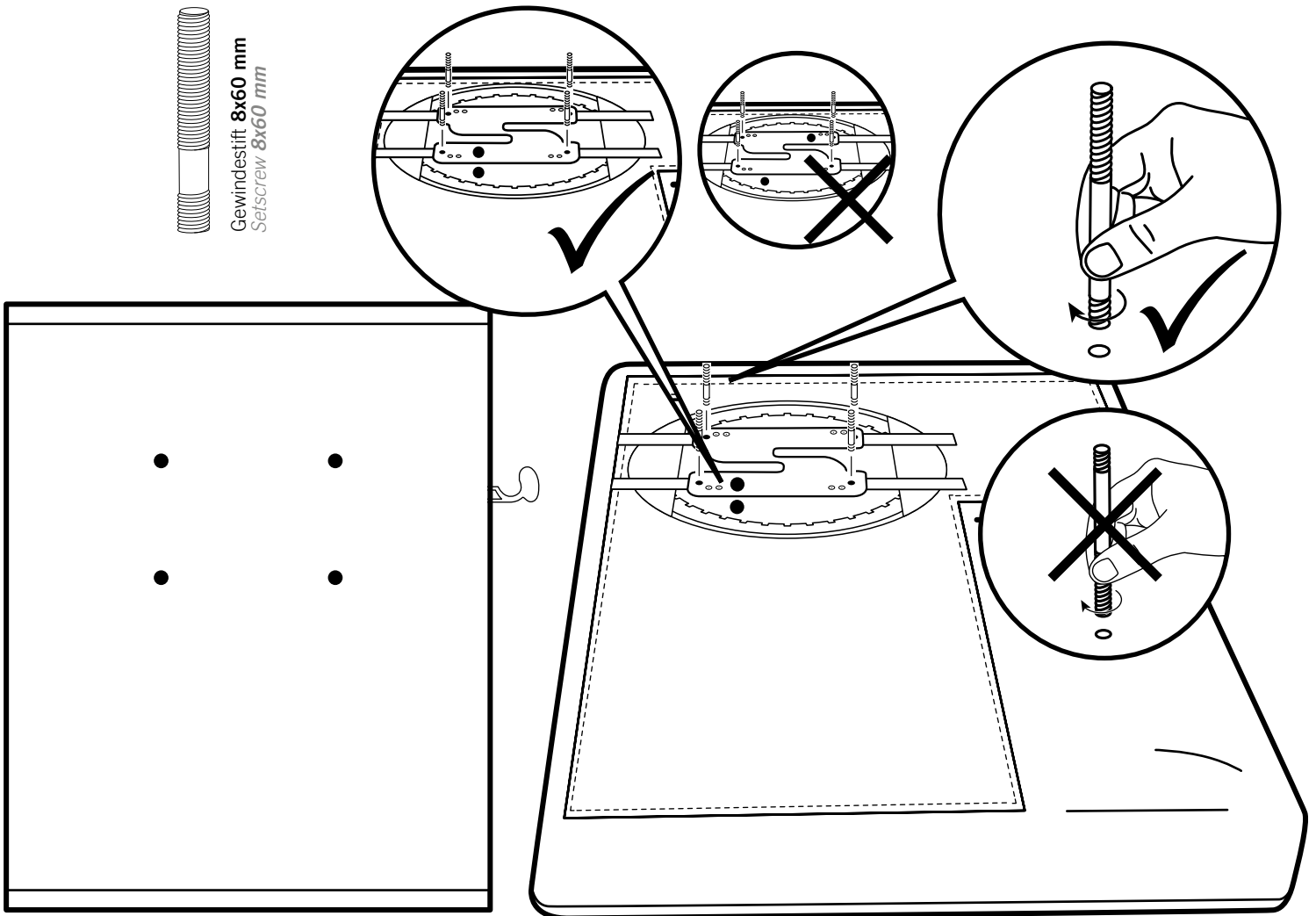
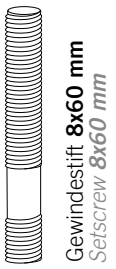

16

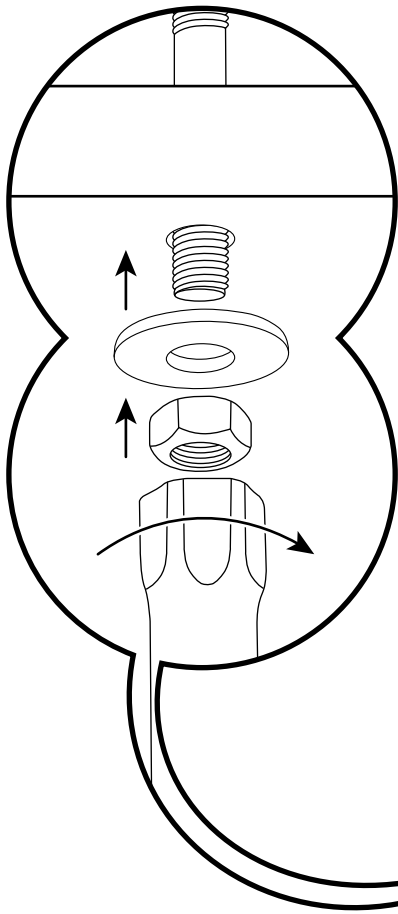

Mutter **M 8**  
Nut **M 8**

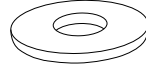

U-Scheibe **8,5mm**  
Plain washer **8.5 mm**

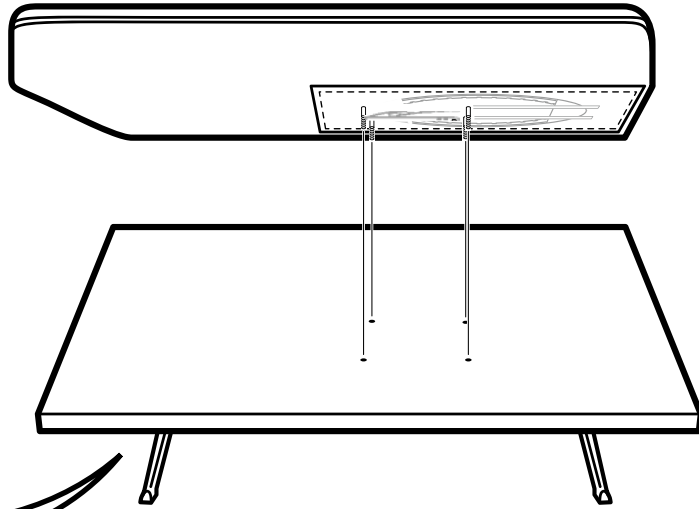

17 Funktionstest / Functional test

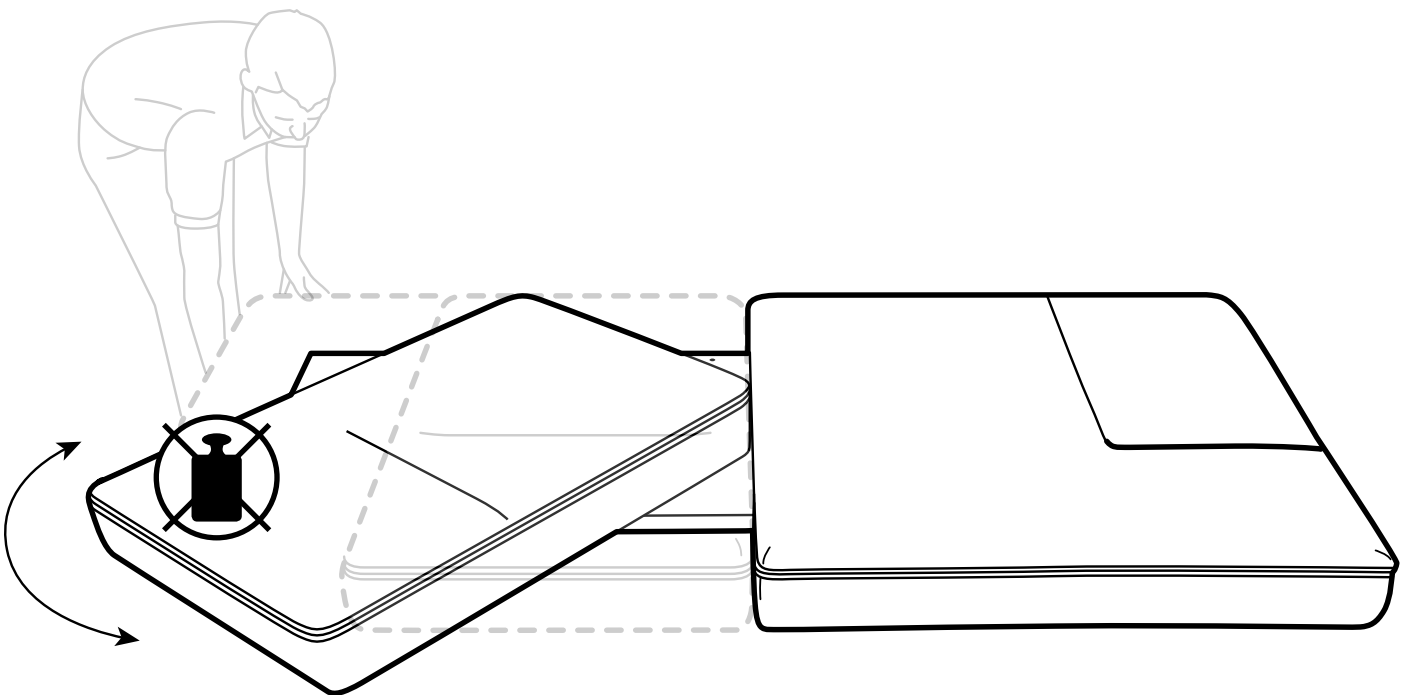

**18** Montage Rücken / *Back assembly*

Gewindestift 8x120 mm  
Setscrew 8x120 mm

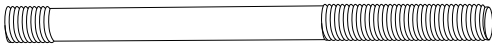

Mutter M 8  
Nut M 8

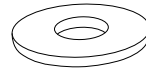

U-Scheibe 8,5 mm  
Plain washer 8,5 mm

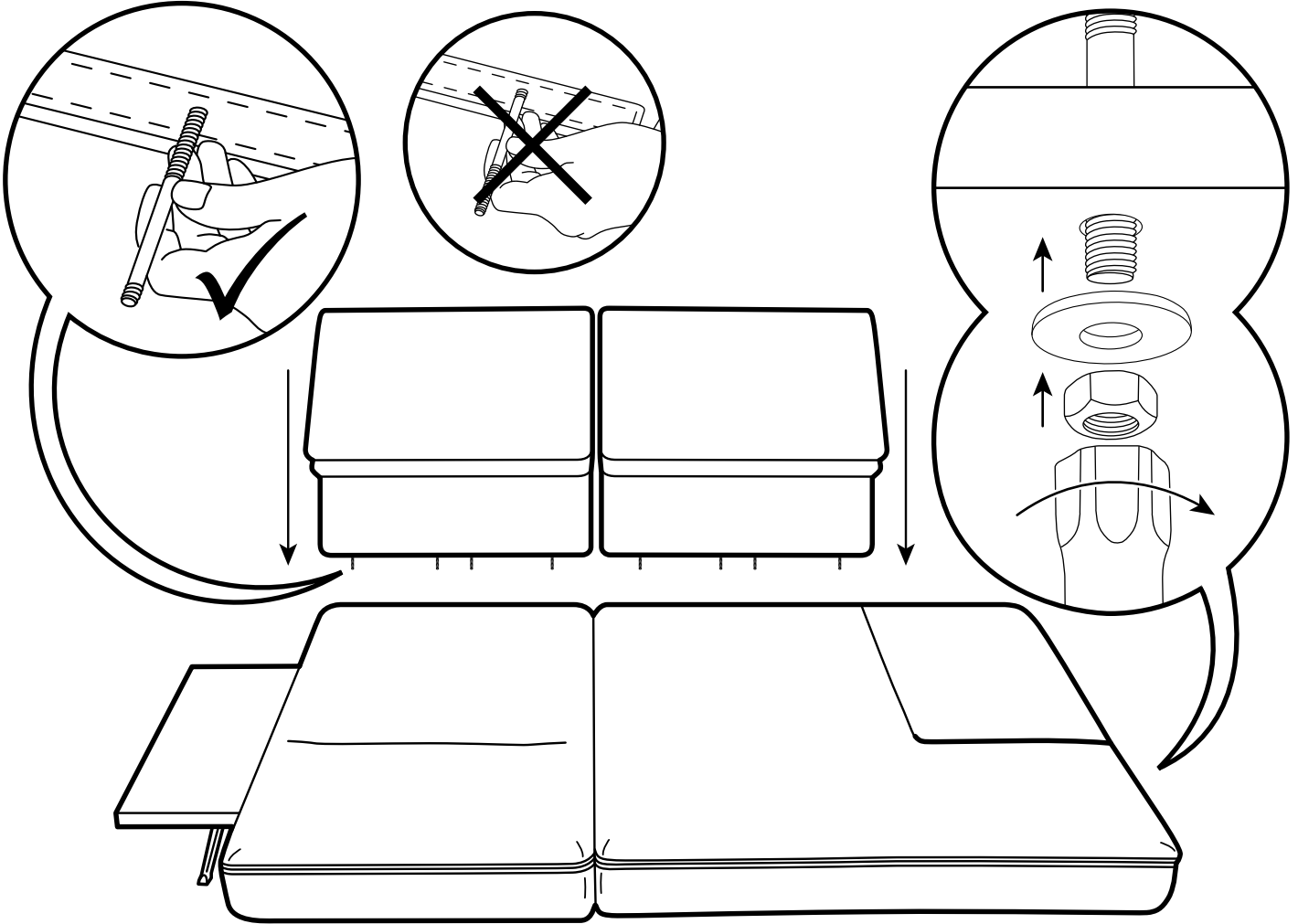

19

Gewindesttift **8x120 mm**  
Setscrew **8x120 mm**

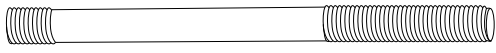

Mutter **M 8**  
Nut **M 8**

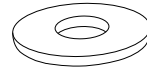

U-Scheibe **8,5 mm**  
Plain washer **8.5 mm**

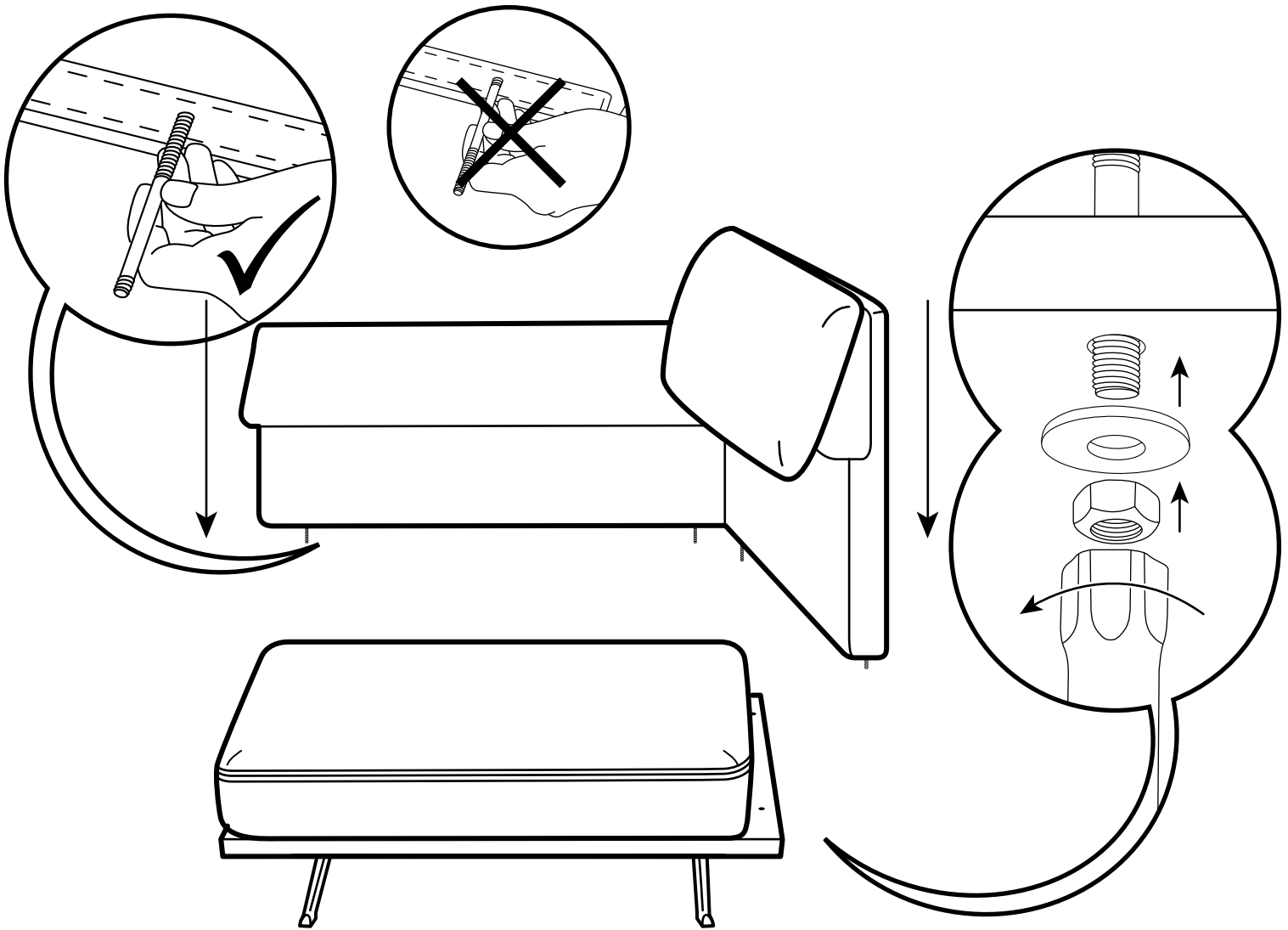

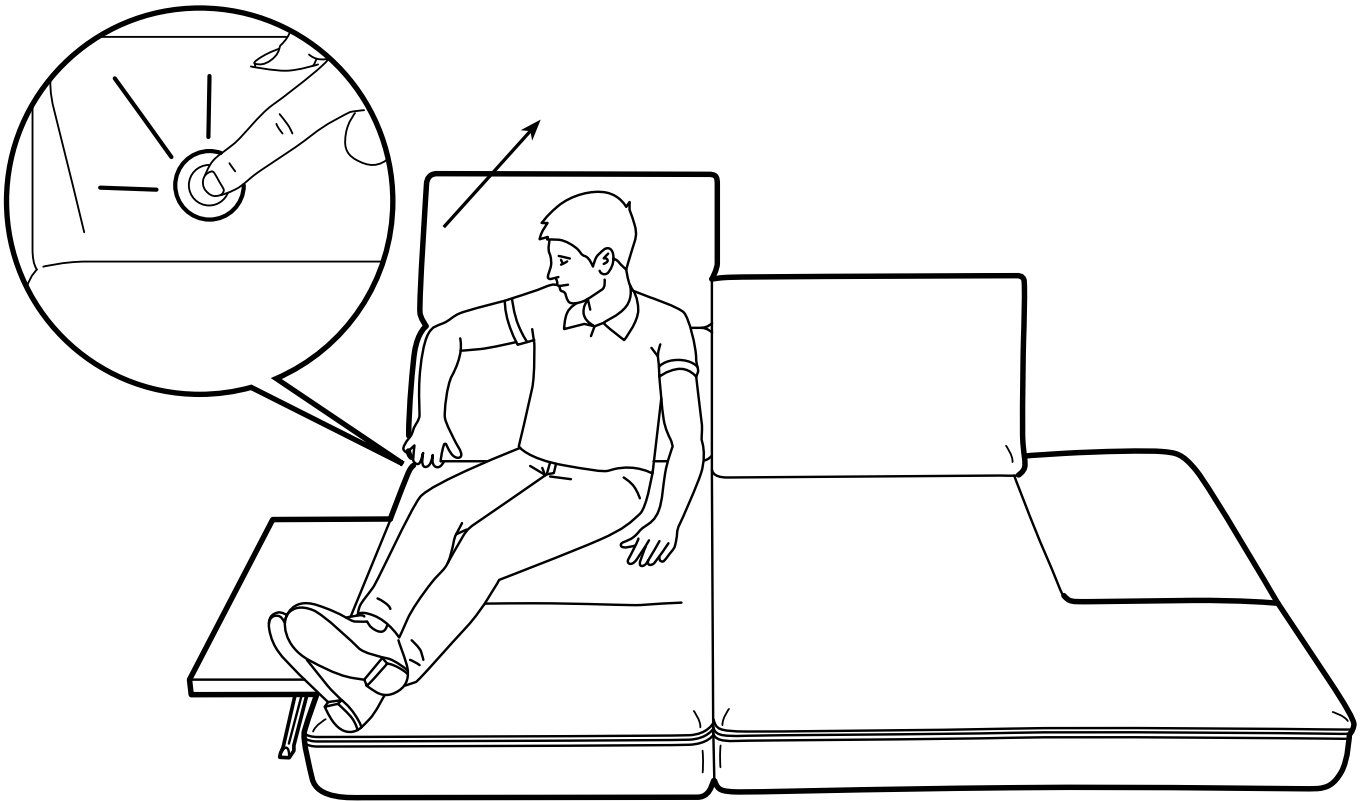
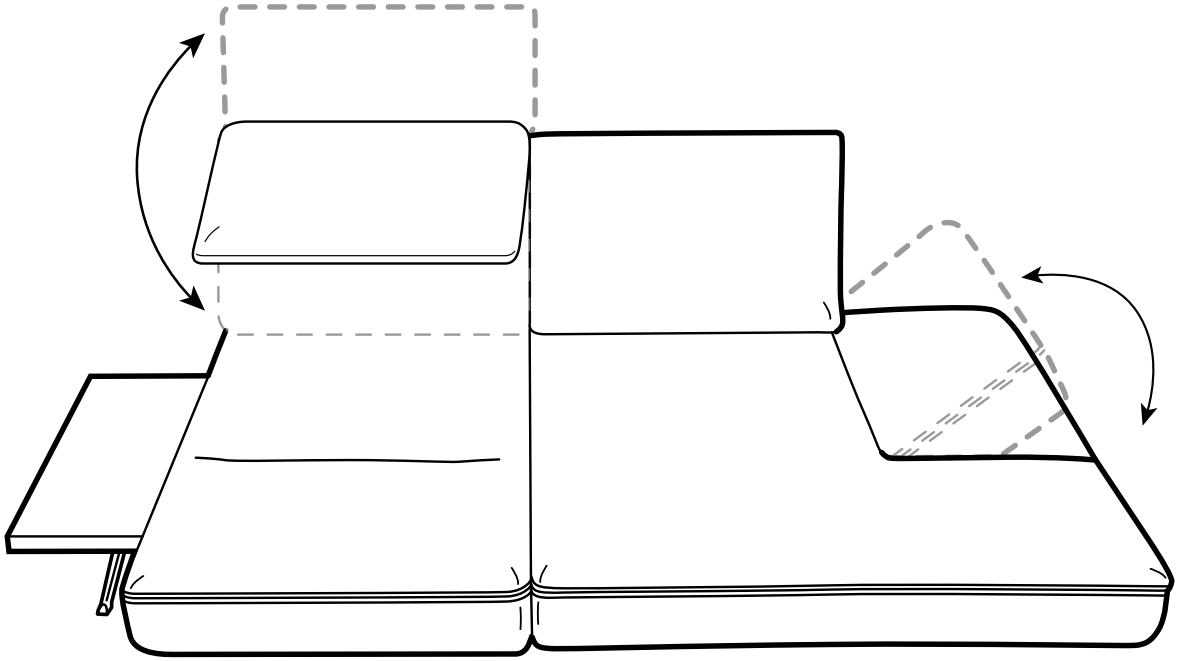



# A186

AUFBAUANLEITUNG - ASSEMBLY INSTRUCTION

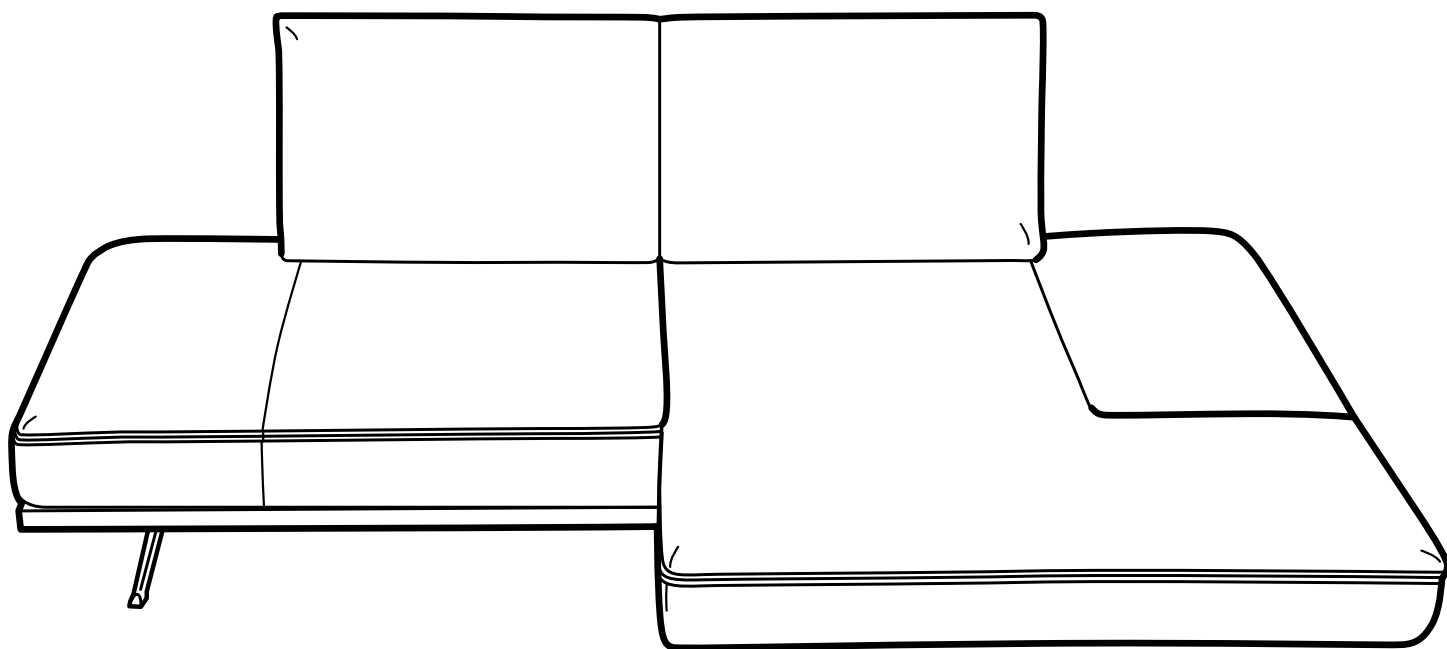

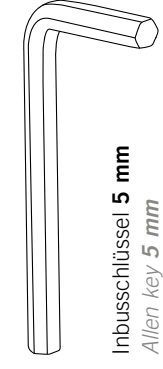

Inbusschlüssel **5 mm**  
*Allen key 5 mm*

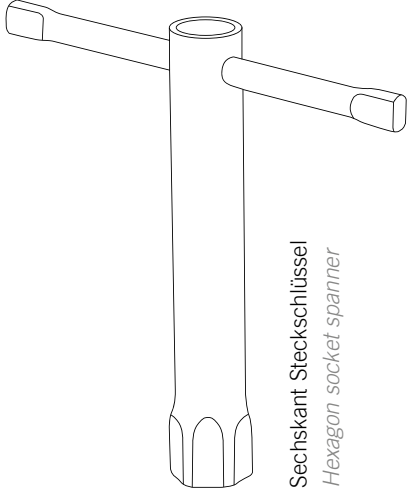

Sechskant Steckschlüssel  
*Hexagon socket spanner*

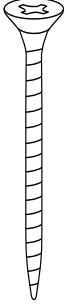

Spaxschraube **5x40 mm**  
*Spax screw 5x40 mm*

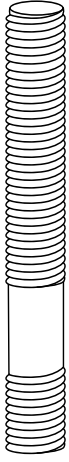

Gewindestift **8x60 mm**  
*Setscrew 8x60 mm*



Gewindestift **8x110 mm**  
*Setscrew 8x110 mm*



Gewindestift **8x120 mm**  
*Setscrew 8x120 mm*

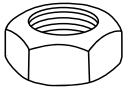

Mutter **M 8**  
*Nut M 8*

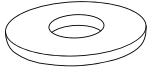

U-Scheibe **8,5 mm**  
*Plain washer 8.5 mm*

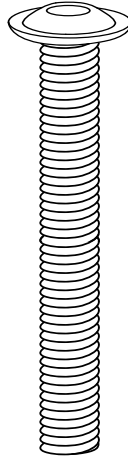

Flanschkopfschraube **8x60 mm**  
*Flange head screw 8x60 mm*

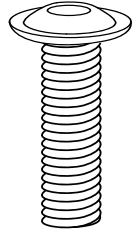

Flanschkopfschraube **8x30 mm**  
*Flange head screw 8x30 mm*

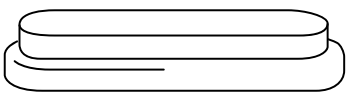

Gleiter Aufsatz **40x10 mm**  
*Glide cap 40x10 mm*

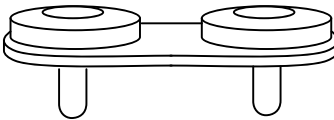

Gleiter Basic **40x10 mm**  
*Glide Basic 40x10 mm*

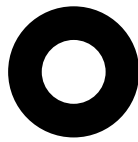

U-Scheibe **22 mm**  
*Plain washer 22 mm*

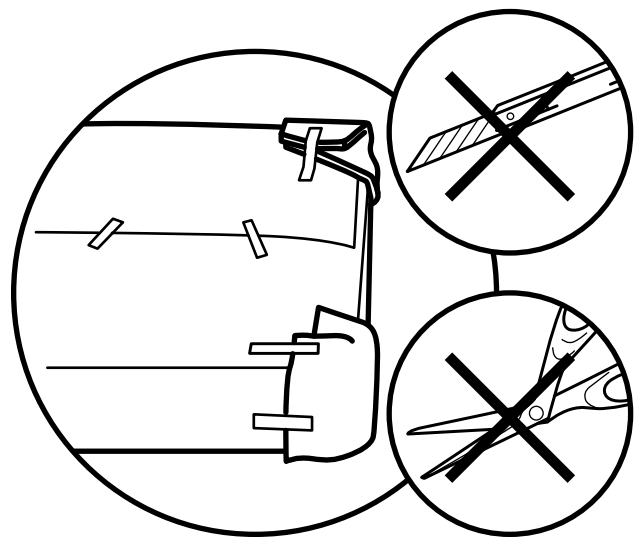
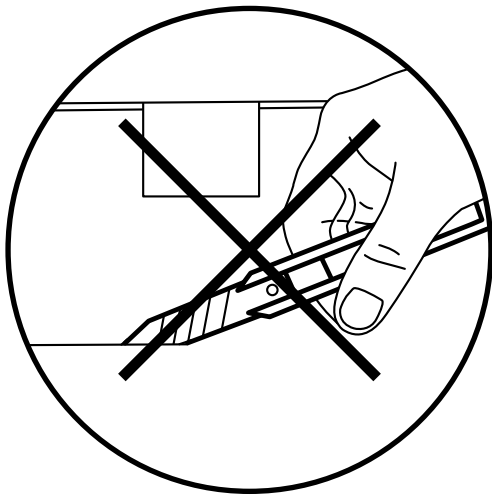
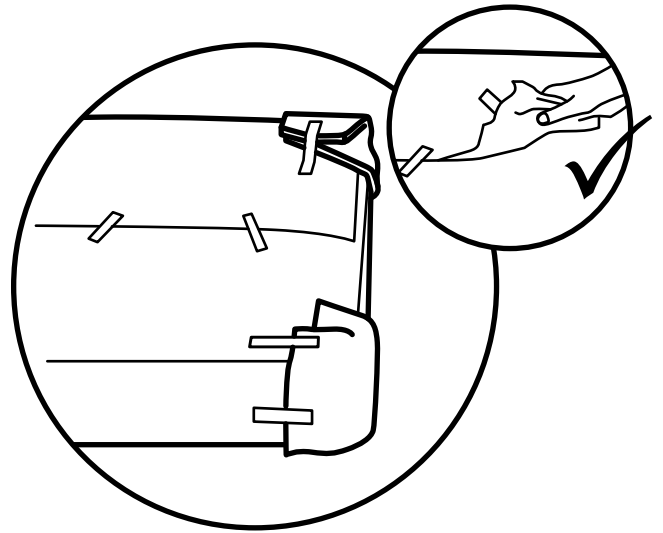
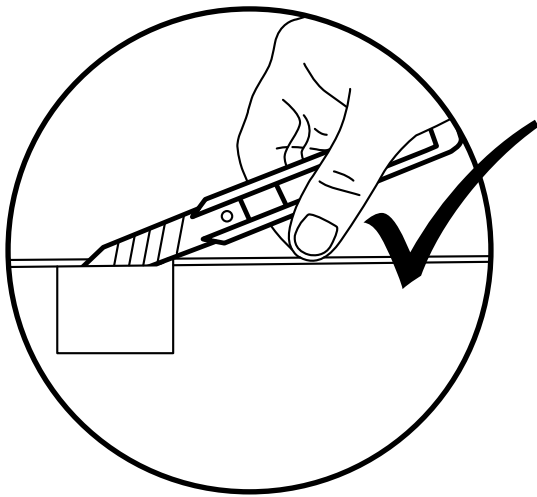

**! Hinweis / Note:**

Für den Aufbau werden zwei Monteure benötigt. Somit vermeiden Sie Beschädigungen im Vorfeld.

*Two persons are needed for the assembly. This prevents damage in advance.*

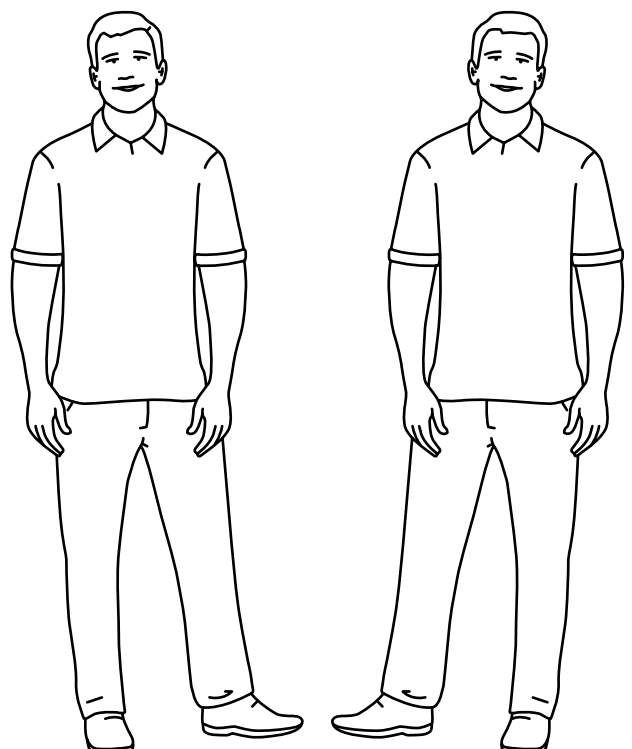

**1** Montage Plateau / Platform assembly

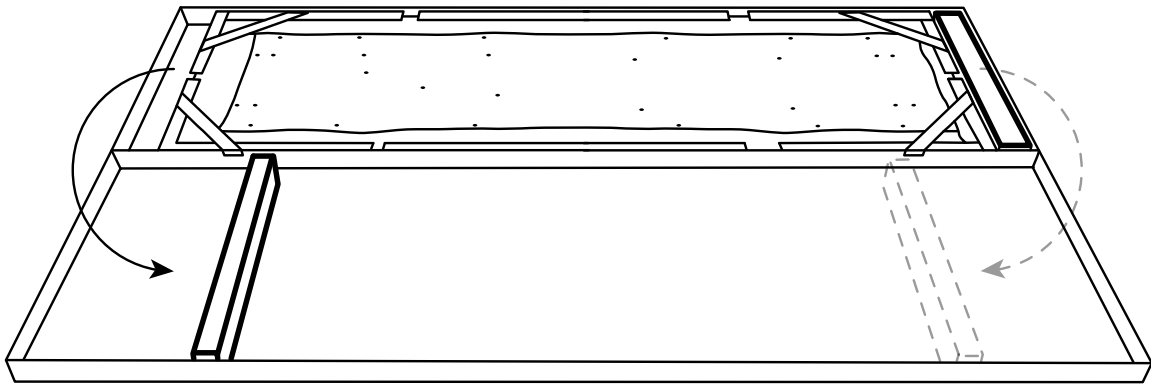

**2**

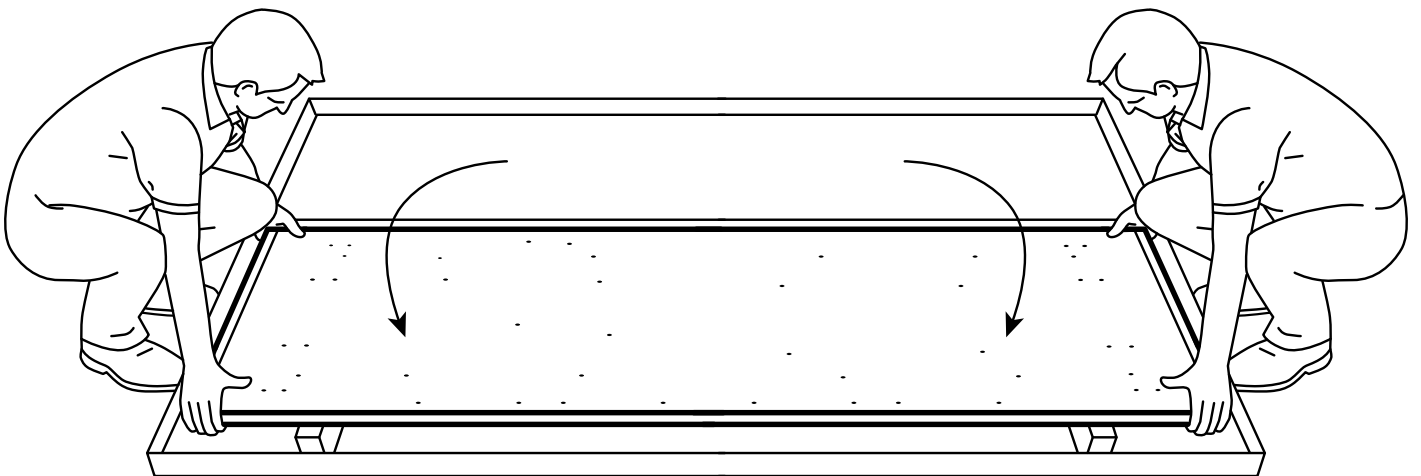

**3**

Flanschkopfschraube 8x60 mm  
Flange head screw 8x60 mm

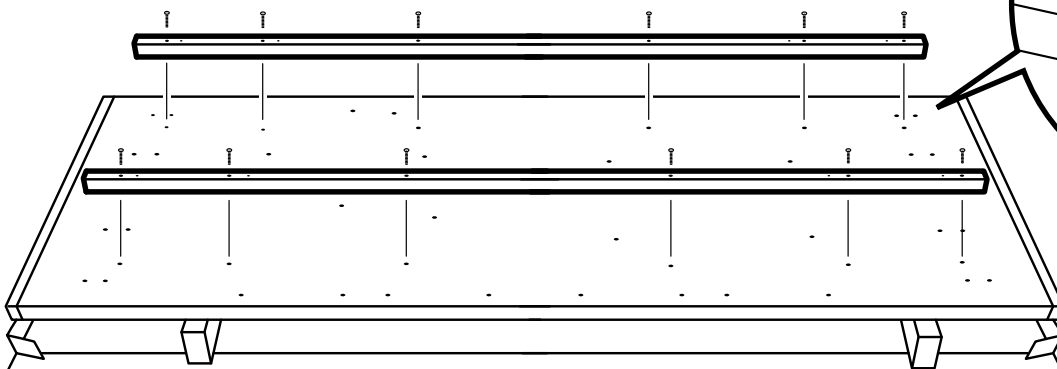
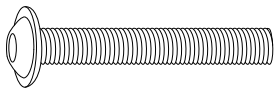

4

Flanschkopfschraube 8x30 mm  
Flange head screw 8x30 mm

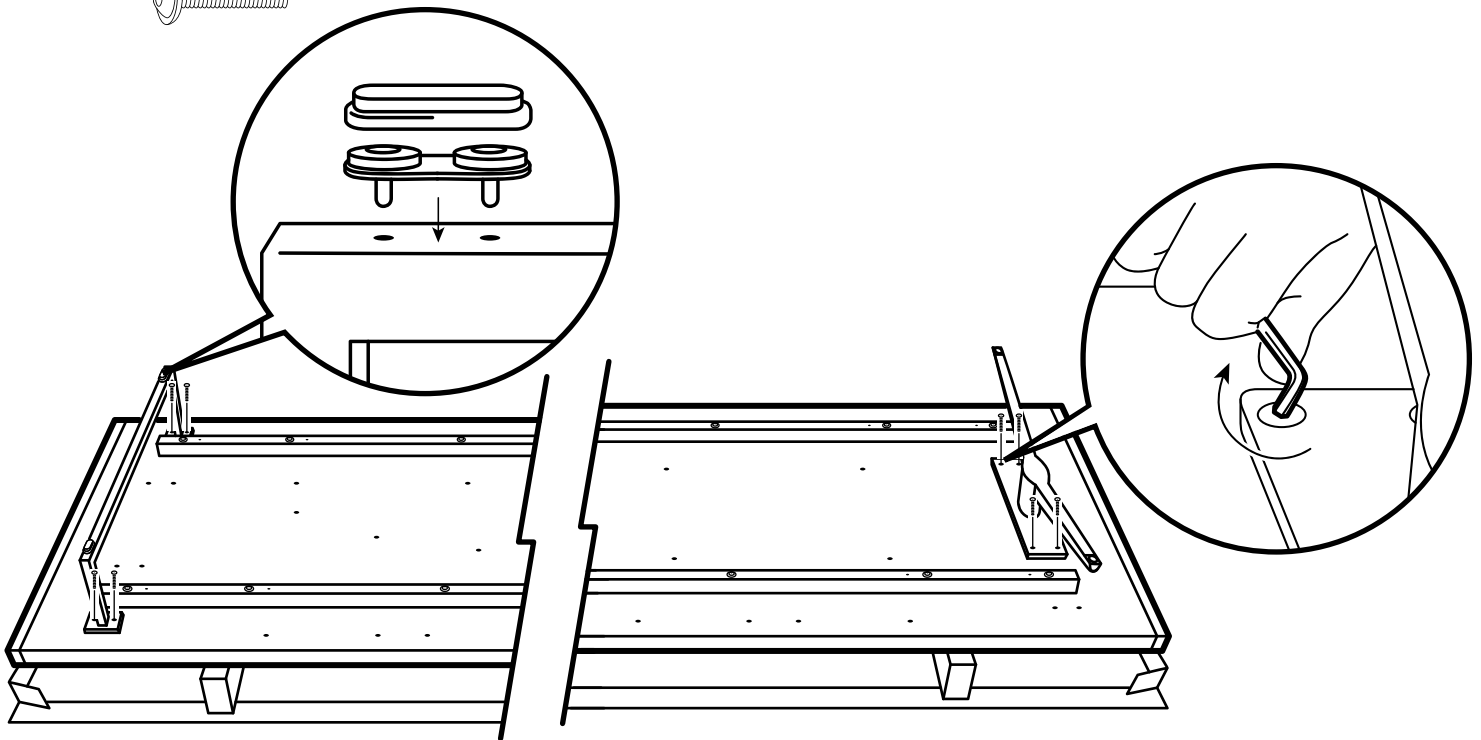
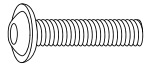

4-Kant Metallkufe  
Metal square-cut runner

Schwertkufe  
Aluminium casting sword runner

4+

Gleiter Basic 40x10 mm  
Glide basic 40x10 mm

Gleiter Aufsatz 40x10 mm  
Glide cap 40x10 mm

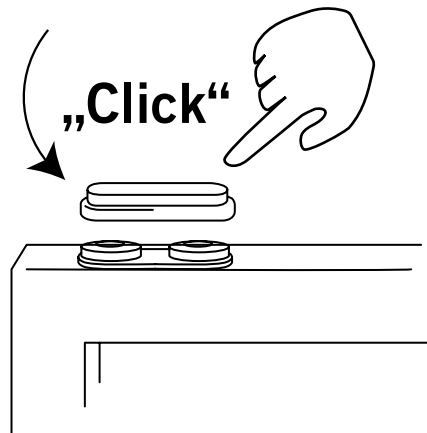
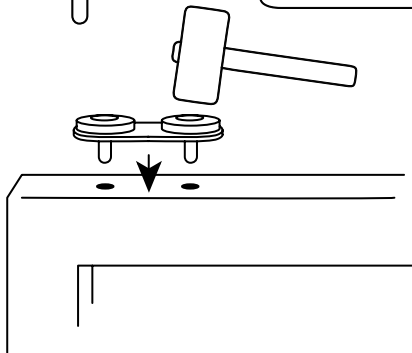
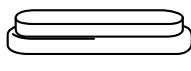
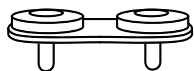

5

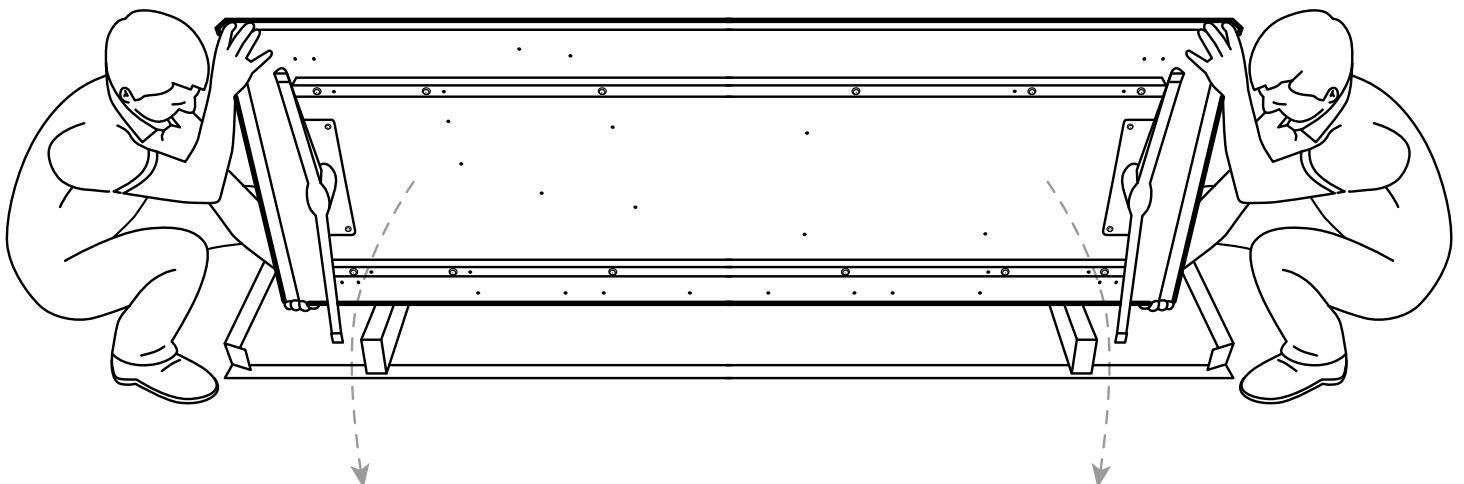

U-Scheibe 22 mm  
Plain washer 22 mm

5 +

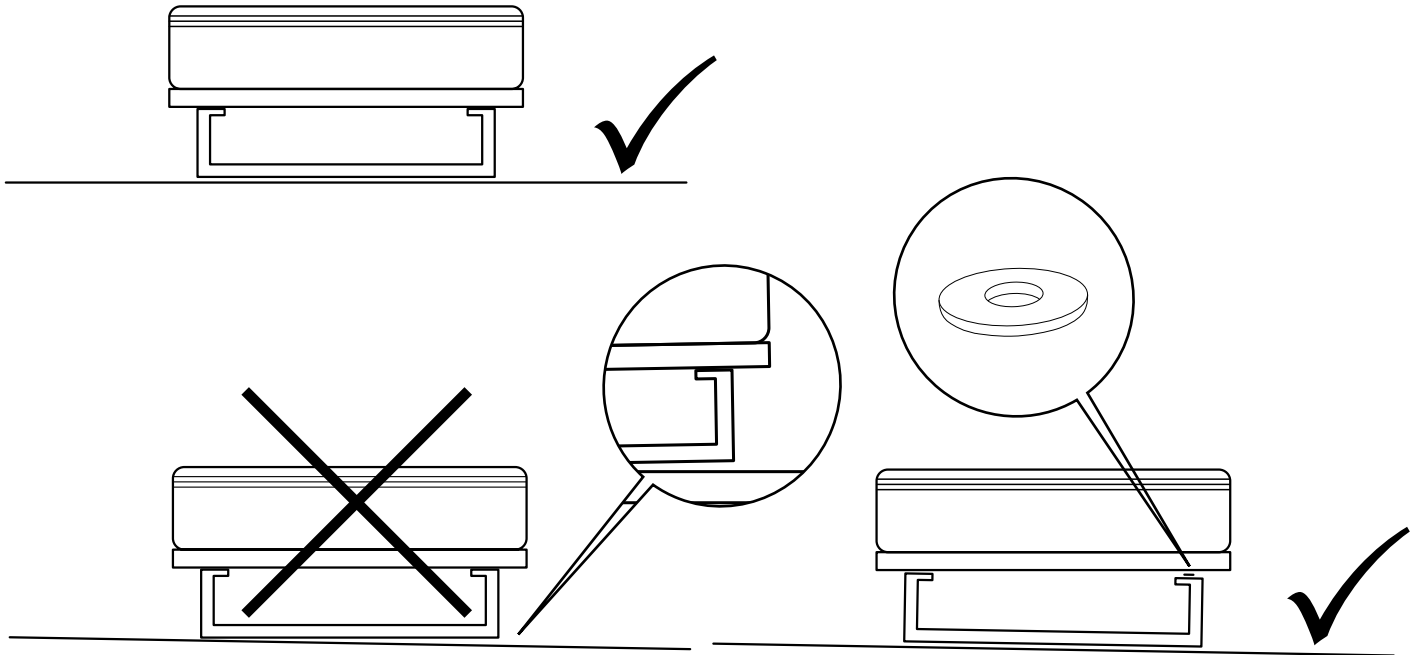

6

Montage Sitzpolster, Festes Element / *Seat cushion assembly, fixed element*



Gewindestift 8x110 mm  
Setscrew 8x110 mm

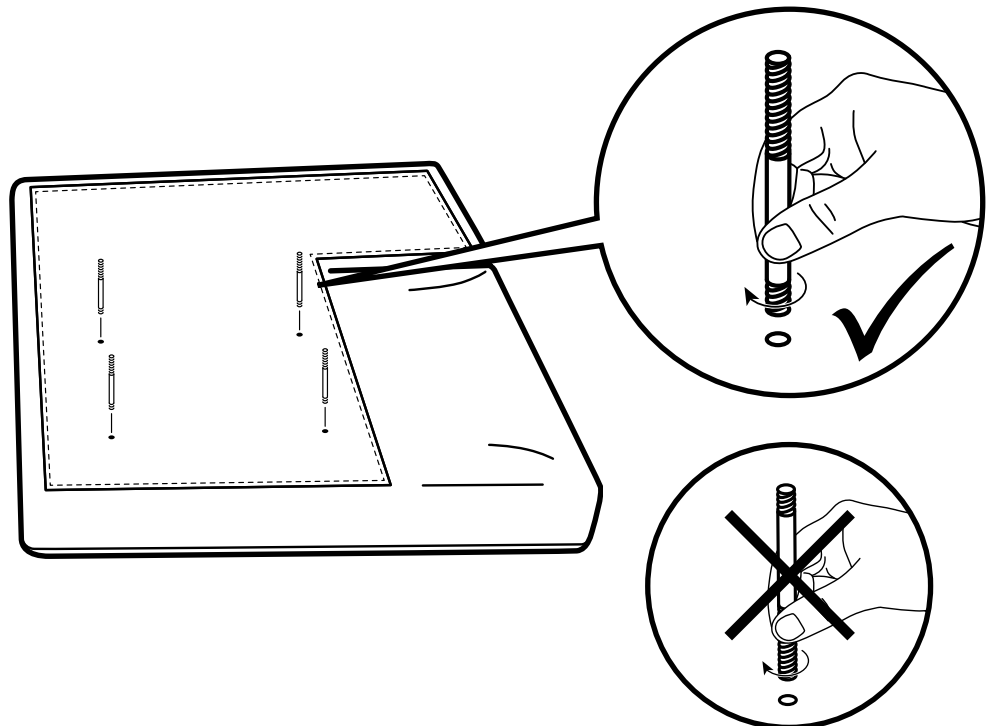

7

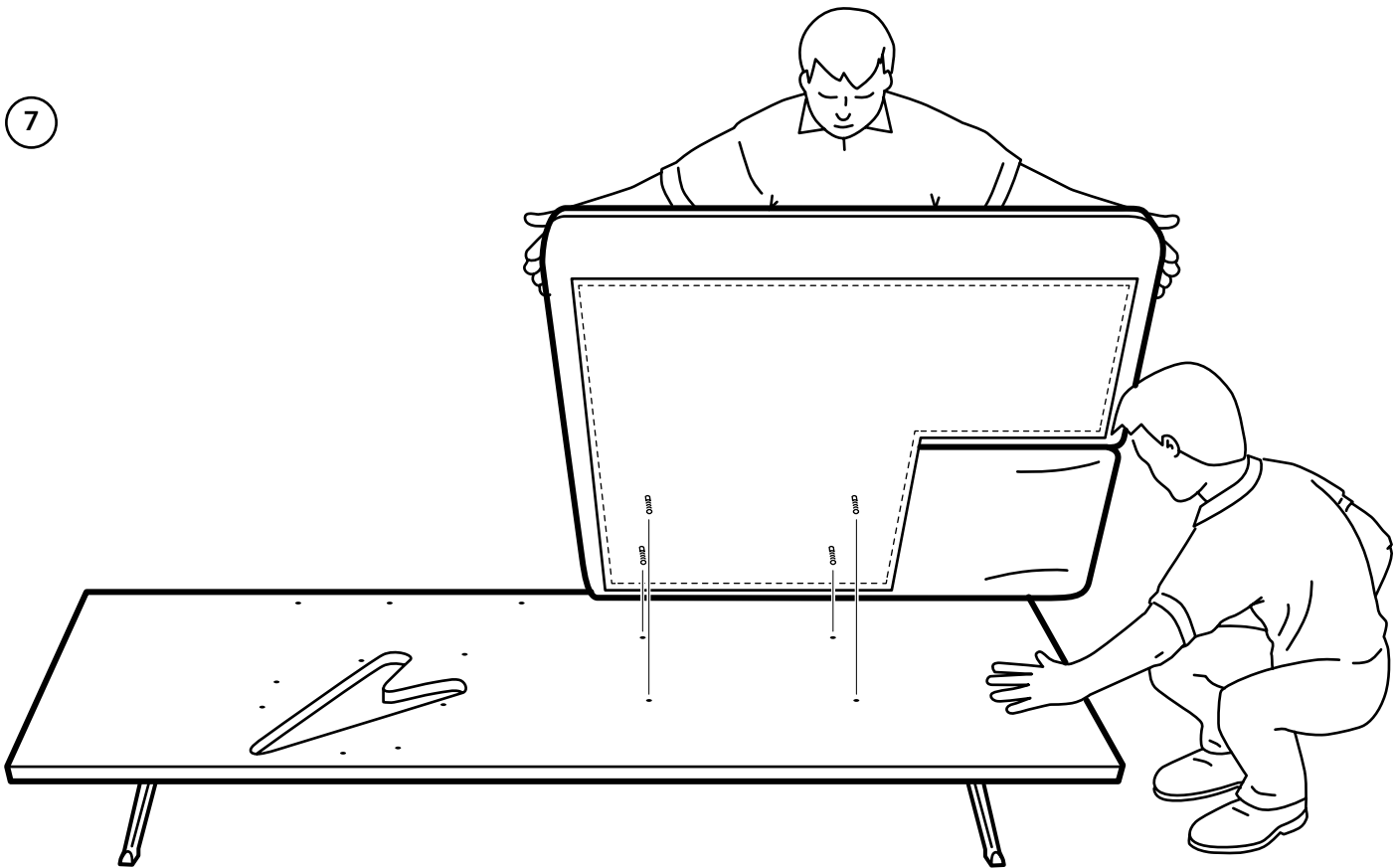

8



Mutter **M 8**  
Nut **M 8**

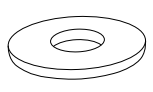

U-Scheibe **8,5mm**  
Plain washer **8.5 mm**

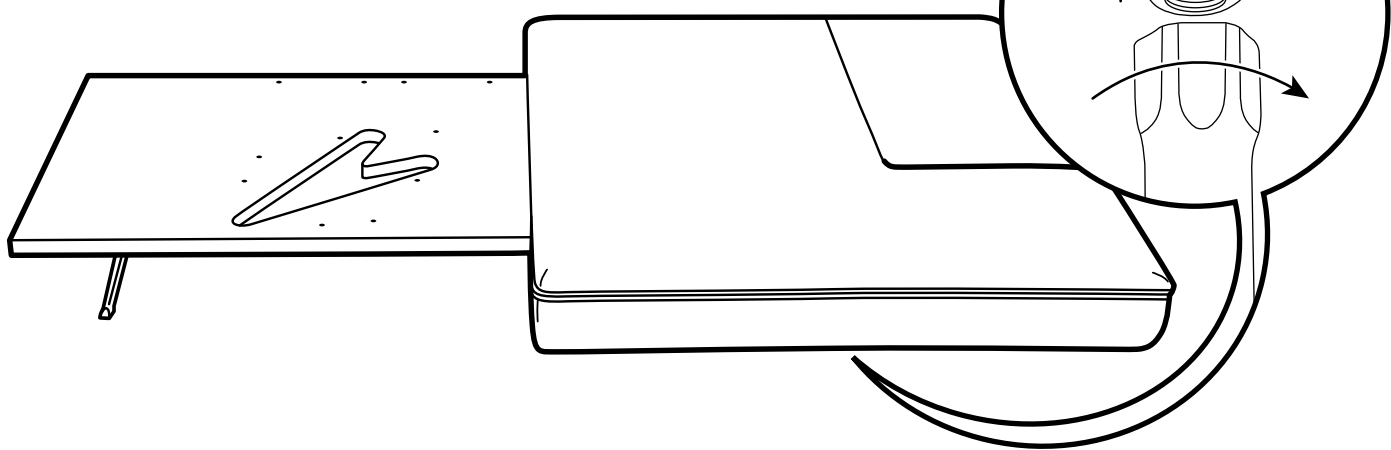

9

Montage Sitzpolster, Schwenkelement / *Seat cushion assembly, swivel element*

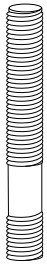

Gewindestift 8x60 mm  
Setscrew 8x60 mm

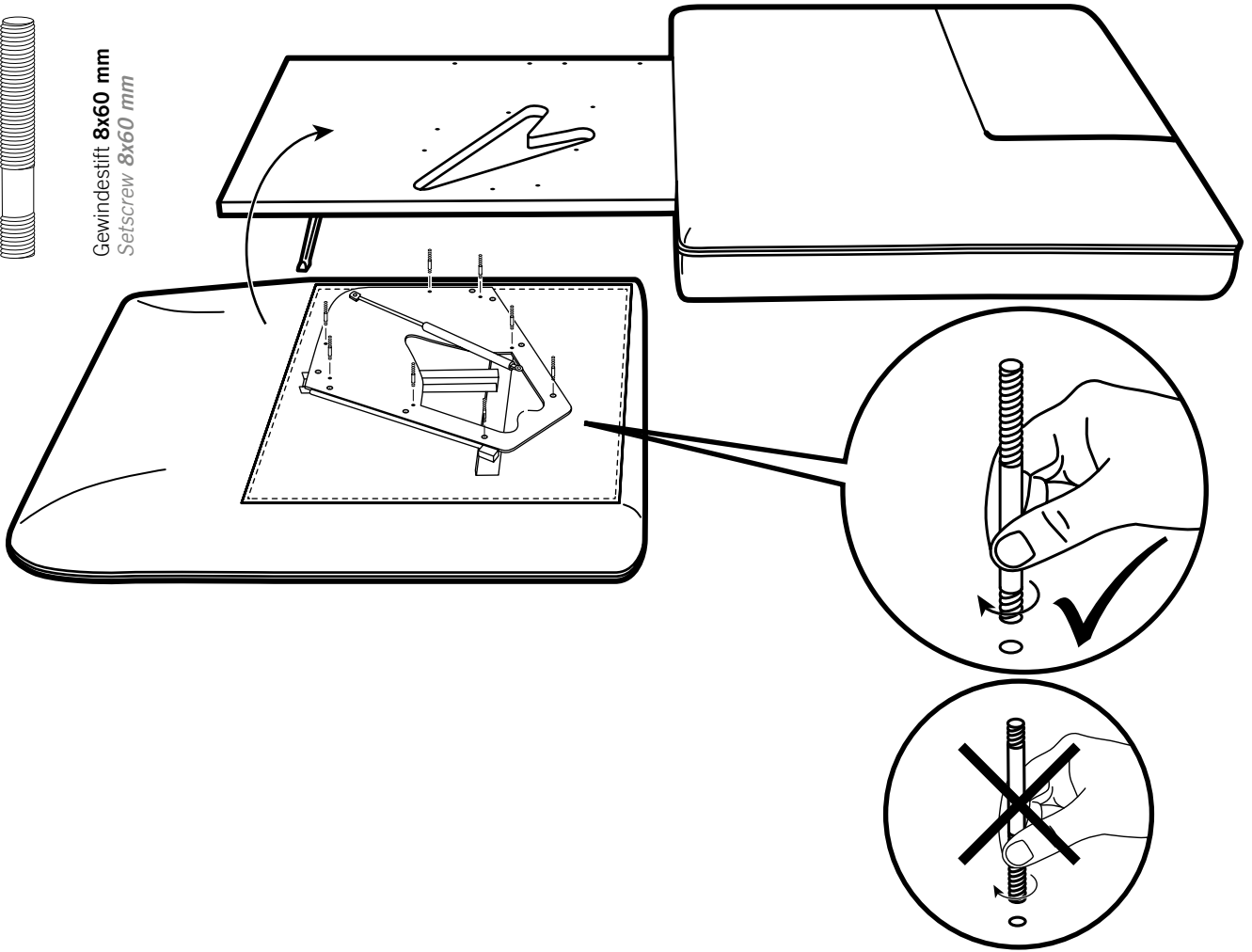

10

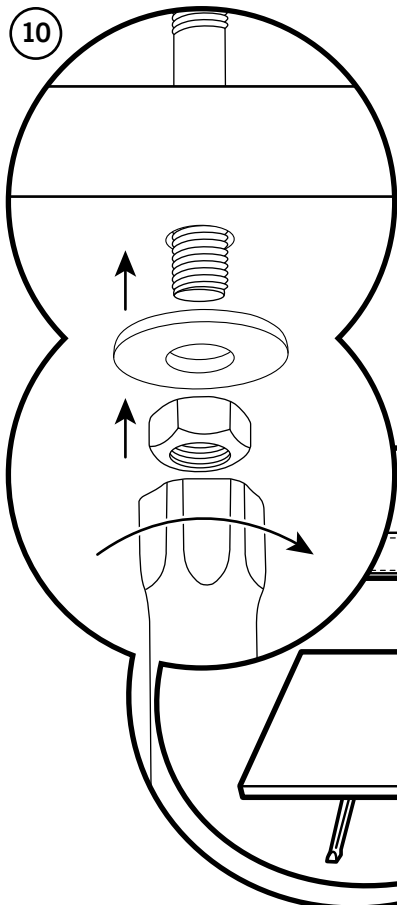

Mutter M 8  
Nut M 8

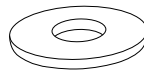

U-Scheibe 8,5mm  
Plain washer 8,5 mm



11 Montage Sitzpolster, Drehelement / *Seat cushion assembly, rotary element*



Gewindestift 8x60 mm  
Setscrew 8x60 mm

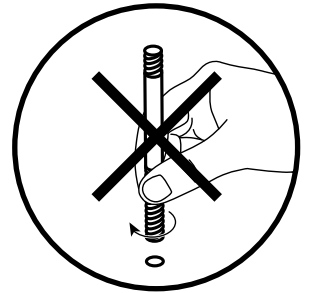
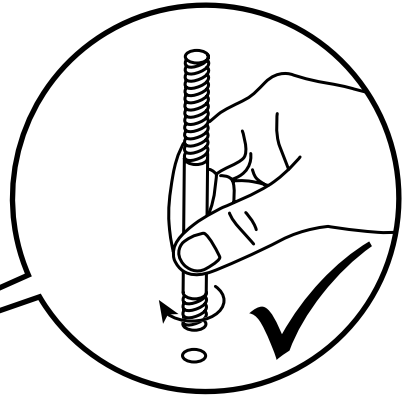
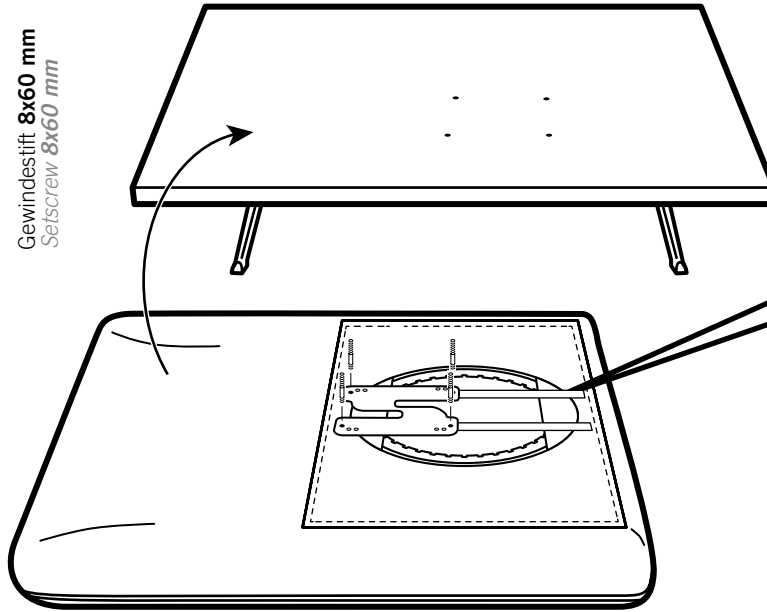

12

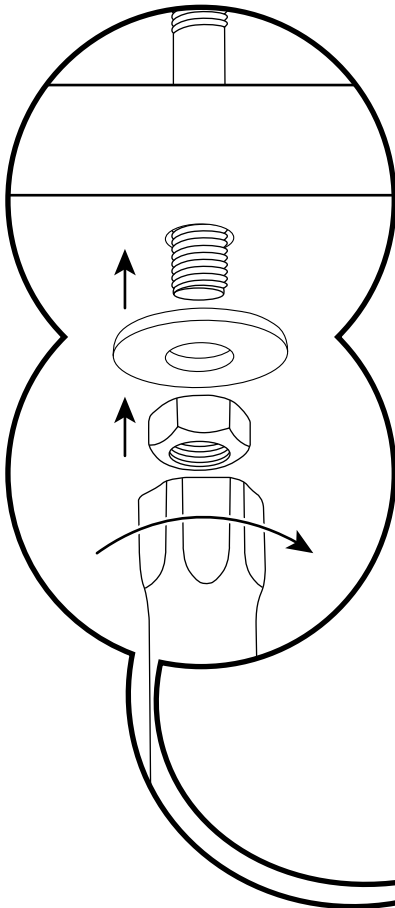

Mutter M 8  
Nut M 8

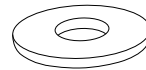

U-Scheibe 8,5mm  
Plain washer 8.5 mm

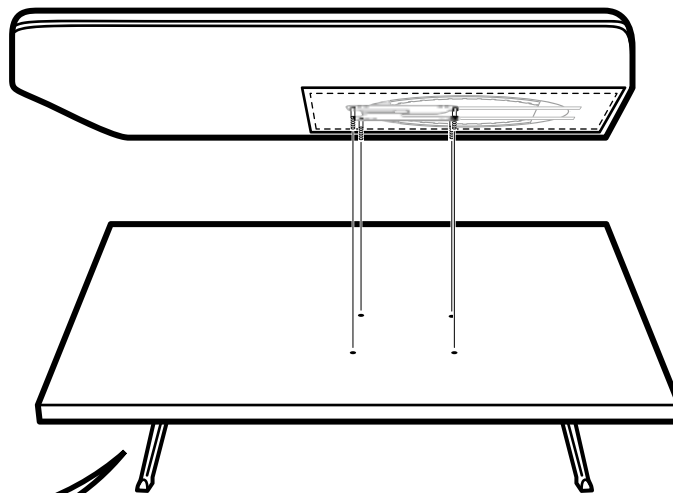

**13** Funktionstest / Functional test

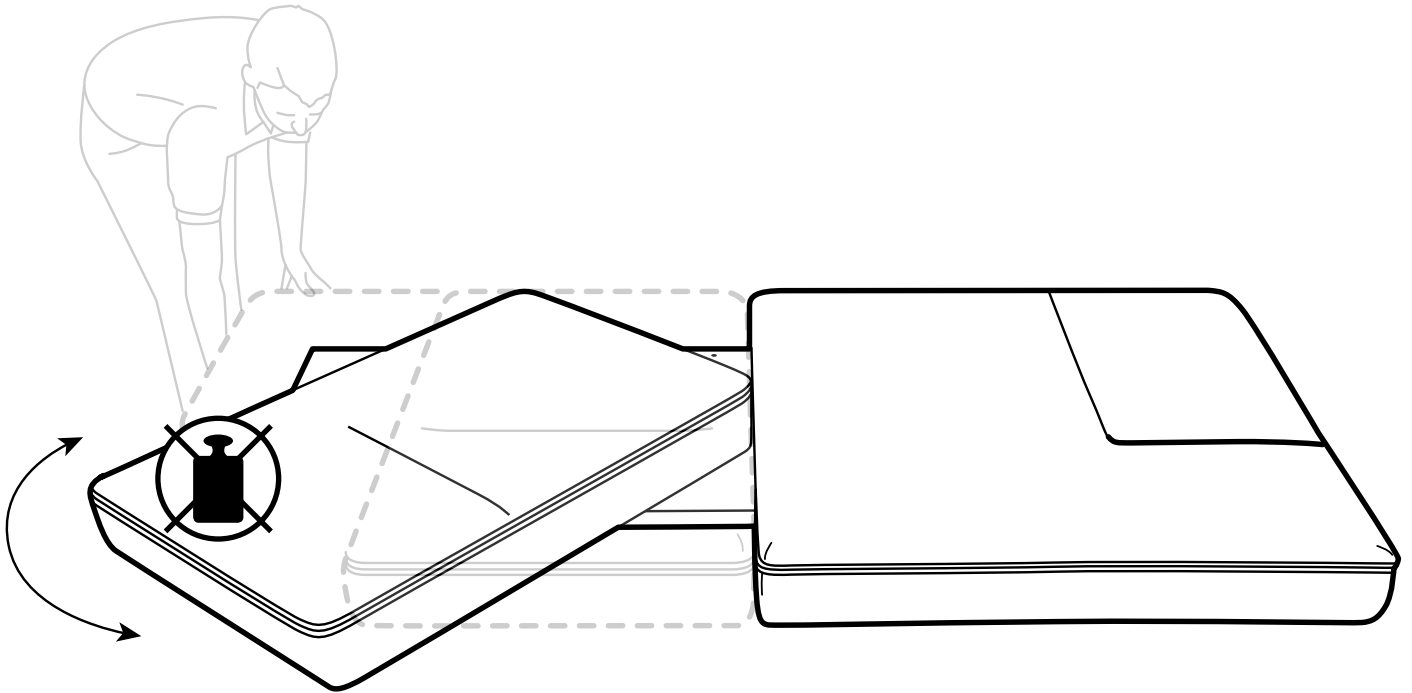

**14** Montage Rücken / Back assembly

Gewindesttift **8x120 mm**  
Setscrew **8x120 mm**

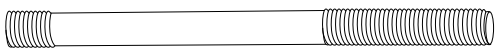

Mutter **M 8**  
Nut **M 8**

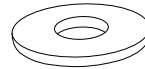

U-Scheibe **8,5 mm**  
Plain washer **8.5 mm**

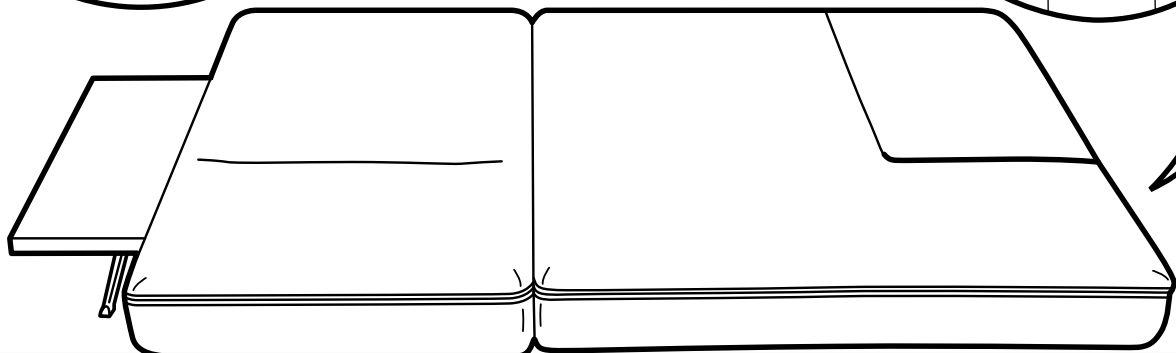
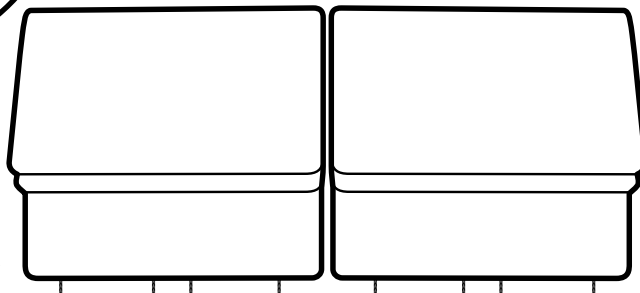
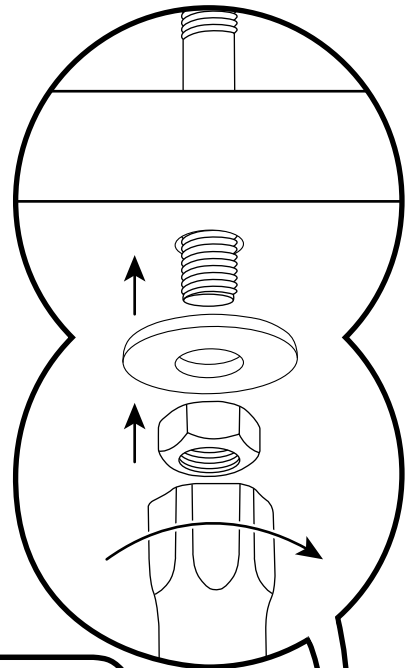
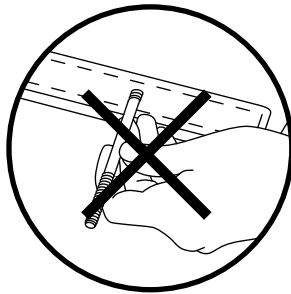

15 Funktionstest / Functional test

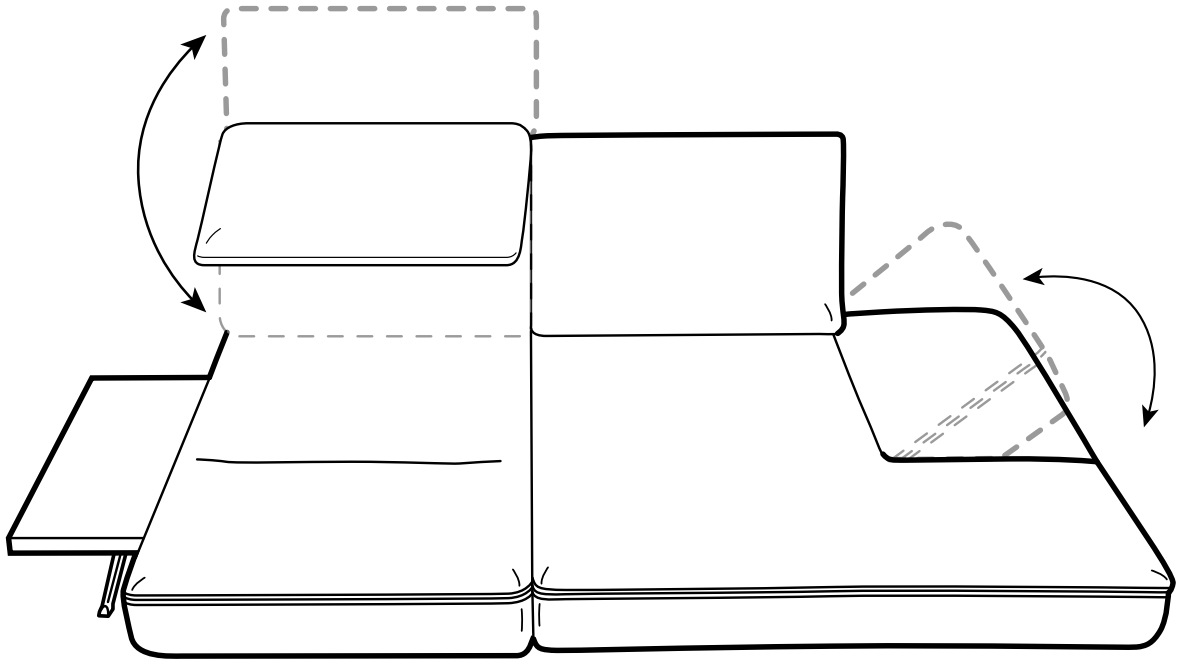

16 Funktionstest / Functional test

